



G-TIME INVERTER SERIES\_R32

# Service Manual

GREE ELECTRIC APPLIANCES, INC. OF ZHUHAI

# Table of Contents

<b>1. Notes for Installation and Maintenance</b>	<b>1</b>
<b>2. Summary</b>	<b>21</b>
2.1 Indoor Unit	21
2.2 Outdoor Unit	21
2.3 Model list	22
<b>3. Specifications</b>	<b>23</b>
3.1 Specification Sheet	23
3.2 Capacity Variation Ratio According to Temperature	39
3.3 Cooling and Heating Data Sheet in Rated Frequency	43
<b>4. Outline Dimension Diagram</b>	<b>44</b>
4.1 Indoor Unit	44
4.2 Outdoor Unit	46
<b>5. Refrigerant System Diagram</b>	<b>47</b>
<b>6. Electrical Part</b>	<b>48</b>
6.1 Wiring Diagram	48
6.2 Printed Circuit Board Diagram	53
<b>7. Function and Control</b>	<b>63</b>
7.1 Remote Controller Introduction for YBE1F	63
7.2 Brief Description of Models and Functions	79
7.3 GREE+ App Operation Manual	107
7.4 Ewpe Smart App Operation Manual	108
<b>8. Installation</b>	<b>109</b>
8.1 Installation Dimension Diagram	109
8.2 Installation Parts-checking	114
8.3 Selection of Installation Location	115
8.4 Electric Connection Requirement	117
8.5 Installation of Indoor Unit	119
8.6 Installation of Outdoor Unit	127

8.7 Vacuum Pumping and Leak Detection.....	133
8.8 Check after Installation and Test Operation.....	135
<b>9. Maintenance .....</b>	<b>137</b>
9.1 Error Code List.....	137
9.2 Procedure of Troubleshooting.....	146
9.3 Checkup .....	195
9.4 Troubleshooting for Normal Malfunction .....	199
<b>10. Removal Procedure .....</b>	<b>204</b>
10.1 Removal Procedure of Indoor Unit.....	204
10.2 Removal Procedure of Outdoor Unit.....	209
<b>Appendix .....</b>	<b>225</b>
Appendix 1 Reference Sheet of Celsius and Fahrenheit .....	225
Appendix 2 Configuration of Connection Pipe .....	228
Appendix 3 Pipe expanding method .....	229
Appendix 4 List of Resistance for Temperature Sensor.....	231
Appendix 5 After-sales debugger operation Instruction .....	234

# 1. Notes for Installation and Maintenance

## ***Safety Precautions: Important!***

Please read the safety precautions carefully before installation and maintenance.

The following contents are very important for installation and maintenance.

Please follow the instructions below:

- The installation or maintenance must accord with the instructions.

---

- Comply with all national electrical codes and local electrical codes.

---

- Pay attention to the warnings and cautions in this manual.

---

- All installation and maintenance shall be performed by distributor or qualified person.

---

- All electric work must be performed by a licensed technician according to local regulations and the instructions given in this manual.

---

- Be caution during installation and maintenance. Prohibit incorrect operation to prevent electric shock, casualty and other accidents.

# WARNINGS

## 1. *Electrical Safety Precautions*

- (1) Cut off the power supply of air conditioner before checking and maintenance.
- (2) The air condition must apply specialized circuit and prohibit share the same circuit with other appliances.
- (3) The air conditioner should be installed in suitable location and ensure the power plug is touchable.
- (4) Make sure each wiring terminal is connected firmly during installation and maintenance.
- (5) Have the unit adequately grounded. The grounding wire can't be used for other purposes.
- (6) Must apply protective accessories such as protective boards, cable-cross loop and wire clip.
- (7) The live wire, neutral wire and grounding wire of power supply must be corresponding to the live wire, neutral wire and grounding wire of the air conditioner.
- (8) The power cord and power connection wires can't be pressed by hard objects.
- (9) If power cord or connection wire is broken, it must be replaced by a qualified person.
- (10) If the power cord or connection wire is not long enough, please get the specialized power cord or connection wire from the manufacture or distributor. Prohibit prolong the wire by yourself.
- (11) For the air conditioner without plug, an air switch must be installed in the circuit. The air switch should be all-pole parting and the contact parting distance should be more than 3mm.
- (12) Make sure all wires and pipes are connected properly and the valves are opened before energizing.
- (13) Check if there is electric leakage on the unit body. If yes, please eliminate the electric leakage.
- (14) Replace the fuse with a new one of the same specification if it is burnt down; Don't replace it with a cooper wire or conducting wire.

- (15) If the unit is to be installed in a humid place, the circuit breaker must be installed.

## **2. Installation Safety Precautions**

- (1) Select the installation location according to the requirement of this manual. (See the requirements in installation part)
- (2) Handle unit transportation with care; the unit should not be carried by only one person if it is more than 20kg.
- (3) When installing the indoor unit and outdoor unit, a sufficient fixing bolt must be installed; make sure the installation support is firm.
- (4) Wear safety belt if the height of working is above 2m.
- (5) Use equipped components or appointed components during installation.
- (6) Make sure no foreign objects are left in the unit after finishing installation.

## **3. Refrigerant Safety Precautions**

- (1) When refrigerant leaks or requires discharge during installation, maintenance, or disassembly, it should be handled by certified professionals or otherwise in compliance with local laws and regulations.
- (2) Avoid contact between refrigerant and fire as it generates poisonous gas; Prohibit prolong the connection pipe by welding.
- (3) Apply specified refrigerant only. Never have it mixed with any other refrigerant. Never have air remain in the refrigerant line as it may lead to rupture or other hazards.
- (4) Make sure no refrigerant gas is leaking out when installation is completed.
- (5) If there is refrigerant leakage, please take sufficient measure to minimize the density of refrigerant.
- (6) Never touch the refrigerant piping or compressor without wearing glove to avoid scald or frostbite.

### **NOTE:**

Improper installation may lead to fire hazard, explosion, electric shock or injury.

## Safety Precautions for Installing and Relocating the Unit

### WARNINGS

- **When installing or relocating the unit, be sure to keep the refrigerant circuit free from air or substances other than the specified refrigerant.**
  - Any presence of air or other foreign substance in the refrigerant circuit will cause system pressure rise or compressor rupture, resulting in injury.
  
- **When installing or moving this unit, do not charge the refrigerant which is not comply with that on the nameplate or unqualified refrigerant.**
  - Otherwise, it may cause abnormal operation, wrong action, mechanical malfunction or even series safety accident.
  
- **When refrigerant needs to be recovered during relocating or repairing the unit, be sure that the unit is running in cooling mode. Then, fully close the valve at high pressure side (liquid valve). About 30~40 seconds later, fully close the valve at low pressure side (gas valve), immediately stop the unit and disconnect power. Please note that the time for refrigerant recovery should not exceed 1 minute.**
  - If refrigerant recovery takes too much time, air may be sucked in and cause pressure rise or compressor rupture, resulting in injury.
  
- **During refrigerant recovery, make sure that liquid valve and gas valve are fully closed and power is disconnected before detaching the connection pipe.**
  - If compressor starts running when stop valve is open and connection pipe is not yet connected, air will be sucked in and cause pressure rise or compressor rupture, resulting in injury.

- **When installing the unit, make sure that connection pipe is securely connected before the compressor starts running.**
  - If compressor starts running when stop valve is open and connection pipe is not yet connected, air will be sucked in and cause pressure rise or compressor rupture, resulting in injury.
  
- **Prohibit installing the unit at the place where there may be leaked corrosive gas or flammable gas.**
  - If there leaked gas around the unit, it may cause explosion and other accidents.
  
- **Do not use extension cords for electrical connections. If the electric wire is not long enough, please contact a local service center authorized and ask for a proper electric wire.**
  - Poor connections may lead to electric shock or fire.
  
- **Use the specified types of wires for electrical connections between the indoor and outdoor units. Firmly clamp the wires so that their terminals receive no external stresses.**
  - Electric wires with insufficient capacity, wrong wire connections and insecure wire terminals may cause electric shock or fire.

## Safety Precautions for Refrigerant

- To realize the function of the air conditioner unit, a special refrigerant circulates in the system. The used refrigerant is the fluoride R32, which is specially cleaned. The refrigerant is flammable and inodorous. Furthermore, it can lead to explosion under certain conditions. But the flammability of the refrigerant is very low. It can be ignited only by fire.
- Compared to common refrigerants, R32 is a nonpolluting refrigerant with no harm to the ozone layer. The influence upon the greenhouse effect is also lower. R32 has got very good thermodynamic features which lead to a really high energy efficiency. The units therefore need a less filling.

## WARNINGS

Do not use means to accelerate the defrosting process or to clean, other than those recommended by the manufacturer. Should repair be necessary, contact your nearest authorized Service Centre. Any repairs carried out by unqualified personnel may be dangerous. The appliance shall be stored in a room without continuously operating ignition sources. (For example: open flames, an operating gas appliance or an operating electric heater.) Do not pierce or burn. Appliance shall be installed, operated and stored in a room with a floor area larger than X m<sup>2</sup>. (Please refer to table "a" in section of "Safety operation of flammable refrigerant" for space X.) Appliance filled with flammable gas R32. For repairs, strictly follow manufacturer's instructions only. Be aware that refrigerants may not contain an odour. Read specialist's manual.

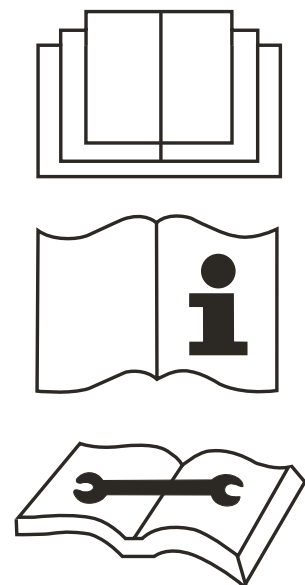

This appliance is not intended for use by persons (including children) with reduced physical, sensory or mental capabilities, or lack of experience and knowledge, unless they have been given supervision or instruction concerning use of the appliance by a person responsible for their safety. Children should be supervised to ensure that they do not play with the appliance.

Hereby, Our company, declares that this Air Conditioner is in compliance with the essential requirement and other relevant provisions of RE Directive 2014/53/EU. A copy of the full DoC is attached. Wireless frequency range: 2412MHz - 2472MHz  
Maximum Transmit Power: 18dBm

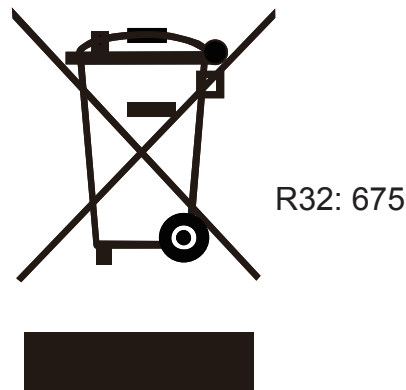

This marking indicates that this product should not be disposed with other household wastes. To prevent possible harm to the environment or human health from uncontrolled waste throughout the EU. To prevent possible harm to the environment or human health.

From uncontrolled waste disposal, recycle it responsibly to promote the sustainable reuse of material resources. To return your used device, please use the return and collection systems or contact the retailer where the product was purchased. They can take this product for environmental safe recycling.

If it needs to install, move or maintain the air conditioner, please contact dealer or local service center to conduct it at first. Air conditioner must be installed, moved or maintained by appointed unit. Otherwise, it may cause serious damage or personal injury or death.

## Safety Operation of Flammable Refrigerant

### 1. Qualification Requirement for Installation and Maintenance Man

- All the work men who are engaging in the refrigeration system should bear the valid certification awarded by the authoritative organization and the qualification for dealing with the refrigeration system recognized by this industry. If it needs other technician to maintain and repair the appliance, they should be supervised by the person who bears the qualification for using the flammable refrigerant.
- It can only be repaired by the method suggested by the equipments manufacturer.

### 2. Installation Notes

- The air conditioner must be installed in a room that is larger than the minimum room area. The minimum room area is shown on the nameplate or following table a.
- It is not allowed to drill hole or burn the connection pipe.
- Leak test is a must after installation.

**table a - Minimum room area ( m<sup>2</sup> )**

Charge amount (kg)	Installation High (m)			
	0.6 (Floor Location)	1.8 (Wall Mounted)	2.2 (Ceiling Mounted)	2.5
	Minimum Room Area (m <sup>2</sup> )			
≤1.224	/	/	/	/
1.3	14.6	1.7	1.1	0.9
1.4	16.9	1.9	1.3	1.0
1.5	19.4	2.2	1.5	1.2
1.6	22.0	2.5	1.7	1.3
1.7	24.9	2.8	1.9	1.5

Charge amount (kg)	Installation High (m)			
	0.6 (Floor Location)	1.8 (Wall Mounted)	2.2 (Ceiling Mounted)	2.5
Minimum Room Area (m <sup>2</sup> )				
1.8	27.9	3.1	2.1	1.7
1.9	31.1	3.5	2.4	1.8
2	34.4	3.9	2.6	2.0
2.1	37.9	4.3	2.9	2.2
2.2	41.6	4.7	3.1	2.4
2.3	45.5	5.1	3.4	2.7
2.4	49.5	5.5	3.7	2.9
2.5	53.7	6.0	4.0	3.1
2.6	58.1	6.5	4.4	3.4
2.7	62.7	7.0	4.7	3.7
2.8	67.4	7.5	5.1	3.9
2.9	72.3	8.1	5.4	4.2
3	77.3	8.6	5.8	4.5
3.1	82.6	9.2	6.2	4.8
3.2	88.0	9.8	6.6	5.1
3.3	93.6	10.4	7.0	5.4

### 3. *Maintenance Notes*

Check whether the maintenance area or the room area meet the requirement of the nameplate.

- **It's only allowed to be operated in the rooms that meet the requirement of the nameplate.**

Check whether the maintenance area is well-ventilated.

- **The continuous ventilation status should be kept during the operation process.**

Check whether there is fire source or potential fire source in the maintenance area.

- **The naked flame is prohibited in the maintenance area; and the "no smoking" warning board should be hanged.**

Check whether the appliance mark is in good condition.

- **Replace the vague or damaged warning mark.**

### 4. *Welding*

- If you should cut or weld the refrigerant system pipes in the process of maintaining, please follow the steps as below:
  - a. Shut down the unit and cut power supply
  - b. Eliminate the refrigerant
  - c. Vacuuming
  - d. Clean it with N<sub>2</sub> gas
  - e. Cutting or welding
  - f. Carry back to the service spot for welding
- Make sure that there isn't any naked flame near the outlet of the vacuum pump and its well-ventilated.
- The refrigerant should be recycled into the specialized storage tank.

## **5. *Filling the Refrigerant***

- Use the refrigerant filling appliances specialized for R32. Make sure that different kinds of refrigerant won't contaminate with each other.
- The refrigerant tank should be kept upright at the time of filling refrigerant.
- Stick the label on the system after filling is finished (or haven't finished).
- Don't overfilling.
- After filling is finished, please do the leakage detection before test running; another time of leak detection should be done when it's removed.

## **6. *Safety Instructions for Transportation and Storage***

- Please use the flammable gas detector to check before unload and open the container.
- No fire source and smoking.
- According to the local rules and laws.

## Specialist's Manual

- **The following checks shall be applied to installations using flammable refrigerants:**
  - the charge size is in accordance with the room size within which the refrigerant containing parts are installed;
  - the ventilation machinery and outlets are operating adequately and are not obstructed;
  - if an indirect refrigerating circuit is being used, the secondary circuit shall be checked for the presence of refrigerant;
  - marking to the equipment continues to be visible and legible. Markings and signs that are illegible shall be corrected;
  - refrigerating pipe or components are installed in a position where they are unlikely to be exposed to any substance which may corrode refrigerant containing components, unless the components are constructed of materials which are inherently resistant to being corroded or are suitably protected against being so corroded.
- Repair and maintenance to electrical components shall include initial safety checks and component inspection procedures. If a fault exists that could compromise safety, then no electrical supply shall be connected to the circuit until it is satisfactorily dealt with. If the fault cannot be corrected immediately but it is necessary to continue operation, an adequate temporary solution shall be used. This shall be reported to the owner of the equipment so all parties are advised.

Initial safety checks shall include:

- that capacitors are discharged: this shall be done in a safe manner to avoid possibility of sparking;
  - that no live electrical components and wiring are exposed while charging, recovering or purging the system;
  - that there is continuity of earth bonding.
- **Checks to the area**

Prior to beginning work on systems containing flammable refrigerants, safety checks are necessary to ensure that the risk of ignition is minimised. For

repair to the refrigerating system, From "Work procedure" to "No ignition sources" shall be completed prior to conducting work on the system.

- **Work procedure**

Work shall be undertaken under a controlled procedure so as to minimise the risk of a flammable gas or vapour being present while the work is being performed.

- **General work area**

All maintenance staff and others working in the local area shall be instructed on the nature of work being carried out. Work in confined spaces shall be avoided.

- **Checking for presence of refrigerant**

The area shall be checked with an appropriate refrigerant detector prior to and during work, to ensure the technician is aware of potentially toxic or flammable atmospheres. Ensure that the leak detection equipment being used is suitable for use with all applicable refrigerants, i.e. non-sparking, adequately sealed or intrinsically safe.

- **Presence of fire extinguisher**

If any hot work is to be conducted on the refrigerating equipment or any associated parts, appropriate fire extinguishing equipment shall be available to hand. Have a dry powder or CO<sub>2</sub> fire extinguisher adjacent to the charging area.

- **No ignition sources**

No person carrying out work in relation to a refrigerating system which involves exposing any pipe work shall use any sources of ignition in such a manner that it may lead to the risk of fire or explosion. All possible ignition sources, including cigarette smoking, should be kept sufficiently far away from the site of installation, repairing, removing and disposal, during which refrigerant can possibly be released to the surrounding space.

Prior to work taking place, the area around the equipment is to be surveyed to make sure that there are no flammable hazards or ignition risks. "No Smoking" signs shall be displayed.

- **Ventilated area**

Ensure that the area is in the open or that it is adequately ventilated before breaking into the system or conducting any hot work. A degree of ventilation

shall continue during the period that the work is carried out. The ventilation should safely disperse any released refrigerant and preferably expel it externally into the atmosphere.

- **Checks to the refrigerating equipment**

Where electrical components are being changed, they shall be fit for the purpose and to the correct specification. At all times the manufacturer's maintenance and service guidelines shall be followed. If in doubt, consult the manufacturer's technical department for assistance.

*The following checks shall be applied to installations using flammable refrigerants:*

- the actual refrigerant charge is in accordance with the room size within which the refrigerant containing parts are installed;
- the ventilation machinery and outlets are operating adequately and are not obstructed;
- if an indirect refrigerating circuit is being used, the secondary circuit shall be checked for the presence of refrigerant;
- marking to the equipment continues to be visible and legible. Markings and signs that are illegible shall be corrected;
- refrigerating pipe or components are installed in a position where they are unlikely to be exposed to any substance which may corrode refrigerant containing components, unless the components are constructed of materials which are inherently resistant to being corroded or are suitably protected against being so corroded.

- **Checks to electrical devices**

Repair and maintenance to electrical components shall include initial safety checks and component inspection procedures. If a fault exists that could compromise safety, then no electrical supply shall be connected to the circuit until it is satisfactorily dealt with. If the fault cannot be corrected immediately but it is necessary to continue operation, an adequate temporary solution shall be used. This shall be reported to the owner of the equipment so all parties are advised.

Initial safety checks shall include:

- that capacitors are discharged: this shall be done in a safe manner to avoid possibility of sparking;

- that no live electrical components and wiring are exposed while charging, recovering or purging the system;
- that there is continuity of earth bonding.

- **Repairs to sealed components**

During repairs to sealed components, all electrical supplies shall be disconnected from the equipment being worked upon prior to any removal of sealed covers, etc. If it is absolutely necessary to have an electrical supply to equipment during servicing, then a permanently operating form of leak detection shall be located at the most critical point to warn of a potentially hazardous situation.

Particular attention shall be paid to the following to ensure that by working on electrical components, the casing is not altered in such a way that the level of protection is affected. This shall include damage to cables, excessive number of connections, terminals not made to original specification, damage to seals, incorrect fitting of glands, etc.

- Ensure that the apparatus is mounted securely.
- Ensure that seals or sealing materials have not degraded to the point that they no longer serve the purpose of preventing the ingress of flammable atmospheres. Replacement parts shall be in accordance with the manufacturer's specifications.

**NOTE:**

The use of silicon sealant can inhibit the effectiveness of some types of leak detection equipment. Intrinsically safe components do not have to be isolated prior to working on them.

- **Repair to intrinsically safe components**

Do not apply any permanent inductive or capacitance loads to the circuit without ensuring that this will not exceed the permissible voltage and current permitted for the equipment in use.

Intrinsically safe components are the only types that can be worked on while live in the presence of a flammable atmosphere. The test apparatus shall be at the correct rating.

Replace components only with parts specified by the manufacturer. Other parts may result in the ignition of refrigerant in the atmosphere from a leak.

- **Cabling**

Check that cabling will not be subject to wear, corrosion, excessive pressure, vibration, sharp edges or any other adverse environmental effects. The check shall also take into account the effects of aging or continual vibration from sources such as compressors or fans.

- **Detection of flammable refrigerants**

Under no circumstances shall potential sources of ignition be used in the searching for or detection of refrigerant leaks. A halide torch (or any other detector using a naked flame) shall not be used.

- **Leak detection methods**

The following leak detection methods are deemed acceptable for all refrigerant systems.

Electronic leak detectors may be used to detect refrigerant leaks but, in the case of flammable refrigerants, the sensitivity may not be adequate, or may need recalibration. (Detection equipment shall be calibrated in a refrigerant-free area.) Ensure that the detector is not a potential source of ignition and is suitable for the refrigerant used. Leak detection equipment shall be set at a percentage of the *LFL* of the refrigerant and shall be calibrated to the refrigerant employed, and the appropriate percentage of gas (25% maximum) is confirmed.

Leak detection fluids are also suitable for use with most refrigerants but the use of detergents containing chlorine shall be avoided as the chlorine may react with the refrigerant and corrode the copper pipe-work.

If a leak is suspected, all naked flames shall be removed/extinguished.

If a leakage of refrigerant is found which requires brazing, all of the refrigerant shall be recovered from the system, or isolated (by means of shut off valves) in a part of the system remote from the leak. For appliances containing flammable refrigerants, oxygen free nitrogen (OFN) shall then be purged through the system both before and during the brazing process.

- **Removal and evacuation**

When breaking into the refrigerant circuit to make repairs — or for any other purpose — conventional procedures shall be used. However, for flammable refrigerants it is important that best practice is followed since flammability is a consideration. The following procedure shall be adhered to:

- remove refrigerant;
- purge the circuit with inert gas;
- evacuate;
- purge with inert gas;
- open the circuit by cutting or brazing.

The refrigerant charge shall be recovered into the correct recovery cylinders. For appliances containing flammable refrigerants, the system shall be "flushed" with OFN to render the unit safe. This process may need to be repeated several times. Compressed air or oxygen shall not be used for purging refrigerant systems.

For appliances containing flammable refrigerants, flushing shall be achieved by breaking the vacuum in the system with OFN and continuing to fill until the working pressure is achieved, then venting to atmosphere, and finally pulling down to a vacuum. This process shall be repeated until no refrigerant is within the system. When the final OFN charge is used, the system shall be vented down to atmospheric pressure to enable work to take place. This operation is absolutely vital if brazing operations on the pipe-work are to take place.

Ensure that the outlet for the vacuum pump is not close to any ignition sources and that ventilation is available.

- **Charging procedures**

In addition to conventional charging procedures, the following requirements shall be followed.

- Ensure that contamination of different refrigerants does not occur when using charging equipment. Hoses or lines shall be as short as possible to minimise the amount of refrigerant contained in them.
- Cylinders shall be kept in an appropriate position according to the instructions.
- Ensure that the refrigerating system is earthed prior to charging the system with refrigerant.
- Label the system when charging is complete (if not already).
- Extreme care shall be taken not to overfill the refrigerating system.

Prior to recharging the system, it shall be pressure-tested with the appropriate purging gas. The system shall be leak-tested on completion of charging but prior to commissioning. A follow up leak test shall be carried out prior to leaving the site.

- **Decommissioning**

Before carrying out this procedure, it is essential that the technician is completely familiar with the equipment and all its detail. It is recommended good practice that all refrigerants are recovered safely. Prior to the task being carried out, an oil and refrigerant sample shall be taken in case analysis is required prior to re-use of recovered refrigerant. It is essential that electrical power is available before the task is commenced.

- a) Become familiar with the equipment and its operation.
- b) Isolate system electrically.
- c) Before attempting the procedure, ensure that:
  - mechanical handling equipment is available, if required, for handling refrigerant cylinders;
  - all personal protective equipment is available and being used correctly;
  - the recovery process is supervised at all times by a competent person;
  - recovery equipment and cylinders conform to the appropriate standards.
- d) Pump down refrigerant system, if possible.
- e) If a vacuum is not possible, make a manifold so that refrigerant can be removed from various parts of the system.
- f) Make sure that cylinder is situated on the scales before recovery takes place.
- g) Start the recovery machine and operate in accordance with manufacturer's instructions.
- h) Do not overfill cylinders. (No more than 80% volume liquid charge).
- i) Do not exceed the maximum working pressure of the cylinder, even temporarily.

- j) When the cylinders have been filled correctly and the process completed, make sure that the cylinders and the equipment are removed from site promptly and all isolation valves on the equipment are closed off.
- k) Recovered refrigerant shall not be charged into another refrigerating system unless it has been cleaned and checked.

- **Labelling**

Equipment shall be labelled stating that it has been de-commissioned and emptied of refrigerant. The label shall be dated and signed. For appliances containing flammable refrigerants, ensure that there are labels on the equipment stating the equipment contains flammable refrigerant.

- **Recovery**

When removing refrigerant from a system, either for servicing or decommissioning, it is recommended good practice that all refrigerants are removed safely.

When transferring refrigerant into cylinders, ensure that only appropriate refrigerant recovery cylinders are employed. Ensure that the correct number of cylinders for holding the total system charge is available. All cylinders to be used are designated for the recovered refrigerant and labelled for that refrigerant (i.e. special cylinders for the recovery of refrigerant). Cylinders shall be complete with pressure-relief valve and associated shut-off valves in good working order. Empty recovery cylinders are evacuated and, if possible, cooled before recovery occurs.

The recovery equipment shall be in good working order with a set of instructions concerning the equipment that is at hand and shall be suitable for the recovery of all appropriate refrigerants including, when applicable, flammable refrigerants. In addition, a set of calibrated weighing scales shall be available and in good working order. Hoses shall be complete with leak-free disconnect couplings and in good condition. Before using the recovery machine, check that it is in satisfactory working order, has been properly maintained and that any associated electrical components are sealed to prevent ignition in the event of a refrigerant release. Consult manufacturer if in doubt.

The recovered refrigerant shall be returned to the refrigerant supplier in the correct recovery cylinder, and the relevant waste transfer note arranged. Do not mix refrigerants in recovery units and especially not in cylinders.

If compressors or compressor oils are to be removed, ensure that they have been evacuated to an acceptable level to make certain that flammable refrigerant does not remain within the lubricant. The evacuation process shall be carried out prior to returning the compressor to the suppliers. Only electric heating to the compressor body shall be employed to accelerate this process. When oil is drained from a system, it shall be carried out safely.

- **General**

That the installation of pipe-work shall be kept to a minimum.

That compliance with national gas regulations shall be observed.

That mechanical connections made in accordance with 22.118 shall be accessible for maintenance purposes.

## 2. Summary

### 2.1 Indoor Unit

**A1**  
panel

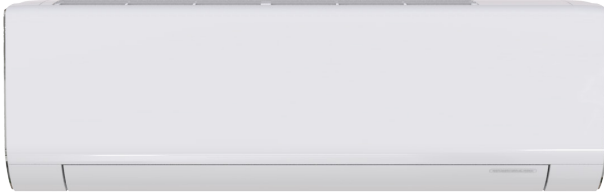

*Remote Controller*



**YBE1F**

### 2.2 Outdoor Unit

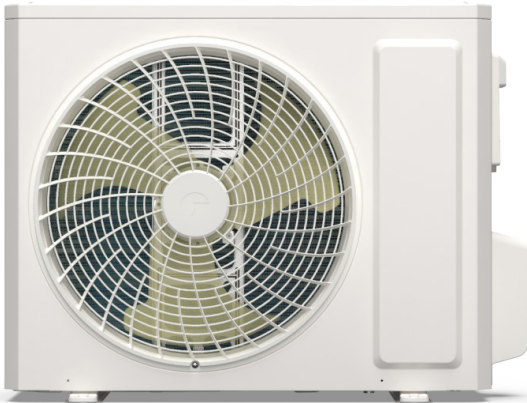

**XB**

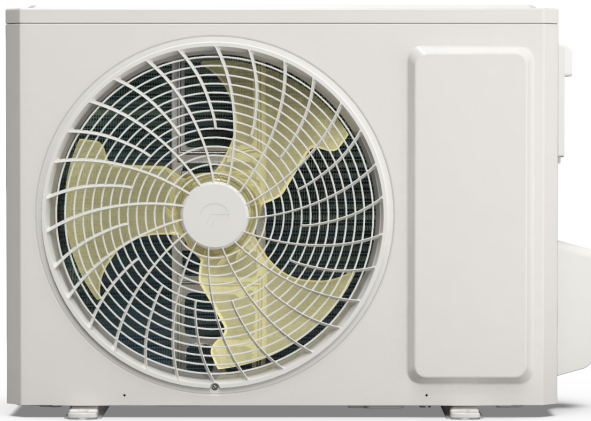

**XD**

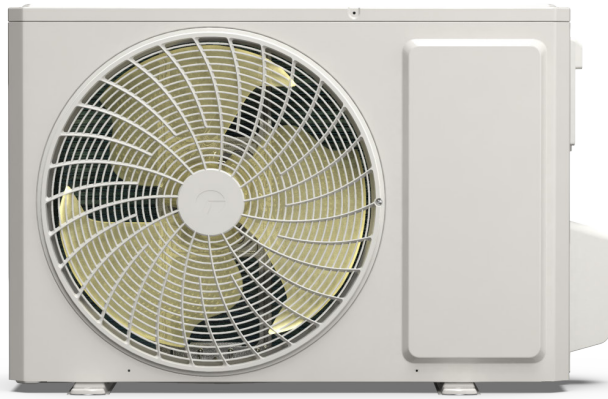

XE

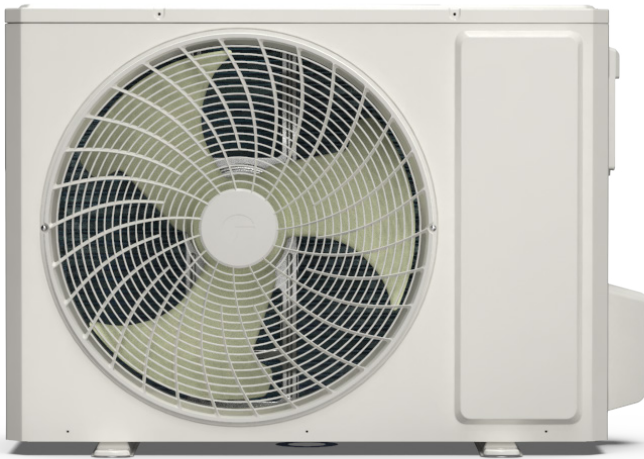

XF

## 2.3 Model list

No.	Model	Product code	Indoor model	Indoor product code	Outdoor model	Outdoor product code	Remote Controller
1	GWH09BCCXB-K6DNA1A	CB665001000	GWH09BCCXB-K6DNA1A/I	CB665N01000	GWH09ACCXB-K6DNA1G/O	CB497W26500	YBE1F
2	GWH12BCCXD-K6DNA1D	CB665002200	GWH12BCCXD-K6DNA1D/I	CB665N02200	GWH12AWCXD-K6DNA1D/O	CB603W10700	
3	GWH18BCDXE-K6DNA1A	CB665002301	GWH18BCDXE-K6DNA1A/I	CB665N02301	GWH18AWDXE-K6DNA4A/O	CB622W03201	
4	GWH24BCEXF-K6DNA1A	CB665002100	GWH24BCEXF-K6DNA1A/I	CB665N02100	GWH24AVEXF-K6DNA1A/O	CB601W00200	

# 3. Specifications

## 3.1 Specification Sheet

### Basic Parameters

<b>Model</b>	-	GWH09BCCXB-K6DNA1A
<b>Product Code</b>	-	CB665001000
<b>Power Supply</b>	<b>Rated Voltage</b>	V~ 220-240
	<b>Rated Frequency</b>	Hz 50
	<b>Phases</b>	- 1
<b>Power Supply Mode</b>	-	Outdoor
<b>Cooling Capacity</b>	W	2700
<b>Heating Capacity</b>	W	3000
<b>Cooling Power Input</b>	W	670
<b>Heating Power Input</b>	W	674
<b>Cooling Current Input</b>	A	3.5
<b>Heating Current Input</b>	A	3.5
<b>Rated Input</b>	W	1400
<b>Rated Cooling Current</b>	A	6
<b>Rated Heating Current</b>	A	6.5
<b>Air Flow Volume</b>	m <sup>3</sup> /h	610/530/500/450/350/290/230/180
<b>Dehumidifying Volume</b>	L/h	0.8
<b>EER</b>	W/W	4.03
<b>COP</b>	W/W	4.45
<b>SEER</b>	-	8.5
<b>SCOP (Average/Warmer/Colder)</b>	-	4.6/5.7/3.5
<b>Application Area</b>	m <sup>2</sup>	12-18

## Indoor Unit Parameters

<b>Indoor Unit Model</b>	-	GWH09BCCXB-K6DNA1A/I
<b>Indoor Unit Product Code</b>	-	CB665N01000
<b>Fan Type</b>	-	Cross-flow
<b>Fan Diameter Length (DXL)</b>	mm	Φ94X630
<b>Cooling Speed</b>	r/min	1250/1100/1050/950/800/700/650/500
<b>Heating Speed</b>	r/min	1250/1100/1040/950/900/880/850
<b>Fan Motor Power Output</b>	W	15
<b>Fan Motor RLA</b>	A	0.22
<b>Fan Motor Capacitor</b>	μF	/
<b>Evaporator Form</b>	-	Aluminum Fin-copper Tube
<b>Evaporator Pipe Diameter</b>	mm	Φ5
<b>Evaporator Row-fin Gap</b>	mm	2-1.3
<b>Evaporator Coil Length (LXDXW)</b>	mm	634X22.8X266.7
<b>Swing Motor Model</b>	-	MP24HF/MP24HF
<b>Swing Motor Power Output</b>	W	1.5/1.5
<b>Fuse Current</b>	A	5.00
<b>Sound Pressure Level</b>	dB (A)	Cooling:39/36/33/30/25/23/21/18 Heating:39/36/34/31/30/29/27
<b>Sound Power Level</b>	dB (A)	Cooling:57/50/47/44/39/36/35/32 Heating:57/50/48/45/44/43/41
<b>Dimension (WXHxD)</b>	mm	886X276X209
<b>Dimension of Carton Box (LXWXH)</b>	mm	944X334X264
<b>Dimension of Package (LXWXH)</b>	mm	949X350X275
<b>Net Weight</b>	kg	9.5
<b>Gross Weight</b>	kg	11.5

## Outdoor Unit Parameters

Outdoor Unit Model	-	GWH09ACCXB-K6DNA1G/O
Outdoor Unit Product Code	-	CB497W26500
Compressor Manufacturer	-	ZHUHAI LANDA COMPRESSOR CO.,LTD.
Compressor Model	-	QXF-N082zC170
Compressor Oil	-	FW68DA or RA68EH equivalent
Compressor Type	-	Rotary
Compressor LRA.	A	/
Compressor RLA	A	3.4
Compressor Power Input	W	630
Compressor Overload Protector	-	/
Throttling Method	-	Electron expansion valve
Set Temperature Range	°C	16~30
Cooling Operation Ambient Temperature Range	°C	-15~50
Heating Operation Ambient Temperature Range	°C	-25~30
Condenser Form	-	Aluminum Fin-copper Tube
Condenser Pipe Diameter	mm	Φ7
Condenser Rows-fin Gap	mm	1-1.2
Condenser Coil Length (LXDXW)	mm	666X19.05X527
Fan Motor Speed	rpm	850
Fan Motor Power Output	W	35
Fan Motor RLA	A	0.4
Fan Motor Capacitor	μF	/
Outdoor Unit Air Flow Volume	m <sup>3</sup> /h	1950
Fan Type	-	Axial-flow

<b>Fan Diameter</b>	mm	Φ400
<b>Defrosting Method</b>	-	Automatic Defrosting
<b>Climate Type</b>	-	T1
<b>Isolation</b>	-	I
<b>Moisture Protection</b>	-	IPX4
<b>Permissible Excessive Operating Pressure for the Discharge Side</b>	MPa	4.3
<b>Permissible Excessive Operating Pressure for the Suction Side</b>	MPa	2.5
<b>Sound Pressure Level</b>	dB (A)	51
<b>Sound Power Level</b>	dB (A)	61
<b>Dimension (WXHxD)</b>	mm	732X555X330
<b>Dimension of Carton Box (LXWXH)</b>	mm	791X373X590
<b>Dimension of Package (LXWXH)</b>	mm	794X376X615
<b>Net Weight</b>	kg	23.5
<b>Gross Weight</b>	kg	26
<b>Refrigerant</b>	-	R32
<b>Refrigerant Charge</b>	kg	0.5

## Connection Pipe Parameters

<b>Connection Pipe Length</b>	m	5
<b>Connection Pipe Gas Additional Charge</b>	g/m	16
<b>Outer Diameter Liquid Pipe</b>	inch	1/4
<b>Outer Diameter Gas Pipe</b>	inch	3/8
<b>Max Distance Height</b>	m	25
<b>Max Distance Length</b>	m	40

*Note: The connection pipe applies metric diameter.*

*The above data is subject to change without notice. Please refer to the nameplate of the unit.*

## Basic Parameters

<b>Model</b>	-	GWH12BCCXD-K6DNA1D
<b>Product Code</b>	-	CB665002200
<b>Power Supply</b>	<b>Rated Voltage</b>	V~ 220-240
	<b>Rated Frequency</b>	Hz 50
	<b>Phases</b>	- 1
<b>Power Supply Mode</b>	-	Outdoor
<b>Cooling Capacity</b>	W	3500
<b>Heating Capacity</b>	W	3800
<b>Cooling Power Input</b>	W	910
<b>Heating Power Input</b>	W	950
<b>Cooling Current Input</b>	A	4.35
<b>Heating Current Input</b>	A	4.67
<b>Rated Input</b>	W	1750
<b>Rated Cooling Current</b>	A	6.67
<b>Rated Heating Current</b>	A	7.75
<b>Air Flow Volume</b>	m <sup>3</sup> /h	650/540/505/405/380/330/310/200
<b>Dehumidifying Volume</b>	L/h	1.4
<b>EER</b>	W/W	3.85
<b>COP</b>	W/W	4
<b>SEER</b>	-	8.5
<b>SCOP (Average/Warmer/Colder)</b>	-	4.8/5.8/-
<b>Application Area</b>	m <sup>2</sup>	16-24

## Indoor Unit Parameters

<b>Indoor Unit Model</b>	-	GWH12BCCXD-K6DNA1D/I
<b>Indoor Unit Product Code</b>	-	CB665N02200
<b>Fan Type</b>	-	Cross-flow
<b>Fan Diameter Length (DXL)</b>	mm	Φ94X630
<b>Cooling Speed</b>	r/min	1400/1200/1120/1050/980/920/750/500
<b>Heating Speed</b>	r/min	1400/1200/1140/1080/1020/960/900
<b>Fan Motor Power Output</b>	W	15
<b>Fan Motor RLA</b>	A	0.22
<b>Fan Motor Capacitor</b>	μF	/
<b>Evaporator Form</b>	-	Aluminum Fin-copper Tube
<b>Evaporator Pipe Diameter</b>	mm	Φ5
<b>Evaporator Row-fin Gap</b>	mm	2-1.3
<b>Evaporator Coil Length (LXDXW)</b>	mm	634X22.8X266.7
<b>Swing Motor Model</b>	-	MP24HF/MP24HF
<b>Swing Motor Power Output</b>	W	1.5/1.5
<b>Fuse Current</b>	A	5
<b>Sound Pressure Level</b>	dB (A)	Cooling:43/39/37/34/32/30/24/18 Heating:44/39/37/35/33/32/31
<b>Sound Power Level</b>	dB (A)	Cooling:58/54/52/49/47/45/39/33 Heating:58/53/51/49/47/46/45
<b>Dimension (WXHxD)</b>	mm	886X276X209
<b>Dimension of Carton Box (LXWXH)</b>	mm	944X334X264
<b>Dimension of Package (LXWXH)</b>	mm	949X350X275
<b>Net Weight</b>	kg	9.5
<b>Gross Weight</b>	kg	11.5

## Outdoor Unit Parameters

Outdoor Unit Model	-	GWH12AWCXD-K6DNA1D/O
Outdoor Unit Product Code	-	CB603W10700
Compressor Manufacturer	-	ZHUHAI LANDA COMPRESSOR CO., LTD
Compressor Model	-	QXF-M098zE170
Compressor Oil	-	FW68DA
Compressor Type	-	Rotary
Compressor LRA.	A	/
Compressor RLA	A	4
Compressor Power Input	W	856.6
Compressor Overload Protector	-	/
Throttling Method	-	Electron expansion valve
Set Temperature Range	°C	16~30
Cooling Operation Ambient Temperature Range	°C	-15~50
Heating Operation Ambient Temperature Range	°C	-25~30
Condenser Form	-	Aluminum Fin-copper Tube
Condenser Pipe Diameter	mm	Φ7
Condenser Rows-fin Gap	mm	1-1.2
Condenser Coil Length (LXDXW)	mm	761.5X38.1X528
Fan Motor Speed	rpm	850
Fan Motor Power Output	W	30
Fan Motor RLA	A	0.4
Fan Motor Capacitor	μF	/
Outdoor Unit Air Flow Volume	m <sup>3</sup> /h	2200
Fan Type	-	Axial-flow

<b>Fan Diameter</b>	mm	Φ420
<b>Defrosting Method</b>	-	Automatic Defrosting
<b>Climate Type</b>	-	T1
<b>Isolation</b>	-	I
<b>Moisture Protection</b>	-	IPX4
<b>Permissible Excessive Operating Pressure for the Discharge Side</b>	MPa	4.3
<b>Permissible Excessive Operating Pressure for the Suction Side</b>	MPa	2.5
<b>Sound Pressure Level</b>	dB (A)	52
<b>Sound Power Level</b>	dB (A)	63
<b>Dimension (WXHXD)</b>	mm	802X555X350
<b>Dimension of Carton Box (LXWXH)</b>	mm	869X395X594
<b>Dimension of Package (LXWXH)</b>	mm	872X398X620
<b>Net Weight</b>	kg	27
<b>Gross Weight</b>	kg	29.5
<b>Refrigerant</b>	-	R32
<b>Refrigerant Charge</b>	kg	0.6

## Connection Pipe Parameters

<b>Connection Pipe Length</b>	m	5
<b>Connection Pipe Gas Additional Charge</b>	g/m	16
<b>Outer Diameter Liquid Pipe</b>	inch	1/4"
<b>Outer Diameter Gas Pipe</b>	inch	3/8"
<b>Max Distance Height</b>	m	10
<b>Max Distance Length</b>	m	20

*Note: The connection pipe applies metric diameter.*

*The above data is subject to change without notice. Please refer to the nameplate of the unit.*

## Basic Parameters

<b>Model</b>	-	GWH18BCDXE-K6DNA1A
<b>Product Code</b>	-	CB665002301
<b>Power Supply</b>	<b>Rated Voltage</b>	V~ 220-240
	<b>Rated Frequency</b>	Hz 50
	<b>Phases</b>	- 1
<b>Power Supply Mode</b>	-	Outdoor
<b>Cooling Capacity</b>	W	5100
<b>Heating Capacity</b>	W	5600
<b>Cooling Power Input</b>	W	1417
<b>Heating Power Input</b>	W	1365
<b>Cooling Current Input</b>	A	6.4
<b>Heating Current Input</b>	A	6.2
<b>Rated Input</b>	W	2300
<b>Rated Cooling Current</b>	A	11.5
<b>Rated Heating Current</b>	A	11.5
<b>Air Flow Volume</b>	m <sup>3</sup> /h	1000/960/870/810/720/640/600/480
<b>Dehumidifying Volume</b>	L/h	1.80
<b>EER</b>	W/W	3.6
<b>COP</b>	W/W	4.1
<b>SEER</b>	-	8.5
<b>SCOP (Average/Warmer/Colder)</b>	-	4.6/5.8/3.7
<b>Application Area</b>	m <sup>2</sup>	23-34

## Indoor Unit Parameters

<b>Indoor Unit Model</b>	-	GWH18BCDXE-K6DNA1A/I
<b>Indoor Unit Product Code</b>	-	CB665N02301
<b>Fan Type</b>	-	Cross-flow
<b>Fan Diameter Length (DXL)</b>	mm	Φ108X691
<b>Cooling Speed</b>	r/min	1150/1100/1030/960/800/750/700/600
<b>Heating Speed</b>	r/min	1200/1150/1040/980/930/880/800
<b>Fan Motor Power Output</b>	W	45
<b>Fan Motor RLA</b>	A	0.25
<b>Fan Motor Capacitor</b>	μF	/
<b>Evaporator Form</b>	-	Aluminum Fin-copper Tube
<b>Evaporator Pipe Diameter</b>	mm	Φ5
<b>Evaporator Row-fin Gap</b>	mm	2-1.2
<b>Evaporator Coil Length (LXDXW)</b>	mm	701X22.8X381
<b>Swing Motor Model</b>	-	MP35CJ/MP24HF
<b>Swing Motor Power Output</b>	W	2.5/1.5
<b>Fuse Current</b>	A	5
<b>Sound Pressure Level</b>	dB (A)	Cooling:47/45/43/41/35/33/30/26 Heating:47/45/42/40/38/36/33
<b>Sound Power Level</b>	dB (A)	Cooling:60/58/56/54/48/46/43/39 Heating:60/58/55/53/51/49/46
<b>Dimension (WXHxD)</b>	mm	1006X333X250
<b>Dimension of Carton Box (LXWXH)</b>	mm	1054X398X318
<b>Dimension of Package (LXWXH)</b>	mm	1059X406X328
<b>Net Weight</b>	kg	14
<b>Gross Weight</b>	kg	16.5

## Outdoor Unit Parameters

Outdoor Unit Model	-	GWH18AWDXE-K6DNA4A/O
Outdoor Unit Product Code	-	CB622W03201
Compressor Manufacturer	-	ZHUHAI LANDA COMPRESSOR CO., LTD.
Compressor Model	-	QXF-M130zF170
Compressor Oil	-	FW68DA or equivalent
Compressor Type	-	Rotary
Compressor LRA.	A	22
Compressor RLA	A	5.36
Compressor Power Input	W	1196
Compressor Overload Protector	-	/
Throttling Method	-	Electron expansion valve
Set Temperature Range	°C	Cooling:16-30 Heating:8-30
Cooling Operation Ambient Temperature Range	°C	-15~50
Heating Operation Ambient Temperature Range	°C	-25~30
Condenser Form	-	Aluminum Fin-copper Tube
Condenser Pipe Diameter	mm	Φ7.94
Condenser Rows-fin Gap	mm	2-1.4
Condenser Coil Length (LXDXW)	mm	833X38.1X528
Fan Motor Speed	rpm	970
Fan Motor Power Output	W	85
Fan Motor RLA	A	1
Fan Motor Capacitor	μF	/
Outdoor Unit Air Flow Volume	m <sup>3</sup> /h	3000
Fan Type	-	Axial-flow

<b>Fan Diameter</b>	mm	Φ445
<b>Defrosting Method</b>	-	Automatic Defrosting
<b>Climate Type</b>	-	T1
<b>Isolation</b>	-	I
<b>Moisture Protection</b>	-	IPX4
<b>Permissible Excessive Operating Pressure for the Discharge Side</b>	MPa	4.3
<b>Permissible Excessive Operating Pressure for the Suction Side</b>	MPa	2.5
<b>Sound Pressure Level</b>	dB (A)	59
<b>Sound Power Level</b>	dB (A)	65
<b>Dimension (WXHxD)</b>	mm	873X555X376
<b>Dimension of Carton Box (LXWXH)</b>	mm	948X428X591
<b>Dimension of Package (LXWXH)</b>	mm	951X431X620
<b>Net Weight</b>	kg	37
<b>Gross Weight</b>	kg	40
<b>Refrigerant</b>	-	R32
<b>Refrigerant Charge</b>	kg	0.95

## Connection Pipe Parameters

<b>Connection Pipe Length</b>	m	5
<b>Connection Pipe Gas Additional Charge</b>	g/m	16
<b>Outer Diameter Liquid Pipe</b>	inch	1/4"
<b>Outer Diameter Gas Pipe</b>	inch	1/2"
<b>Max Distance Height</b>	m	10
<b>Max Distance Length</b>	m	25

*Note: The connection pipe applies metric diameter.*

*The above data is subject to change without notice. Please refer to the nameplate of the unit.*

## Basic Parameters

<b>Model</b>	-	GWH24BCEXF-K6DNA1A
<b>Product Code</b>	-	CB665002100
<b>Power Supply</b>	<b>Rated Voltage</b>	V~ 220-240
	<b>Rated Frequency</b>	Hz 50
	<b>Phases</b>	- 1
<b>Power Supply Mode</b>	-	Outdoor
<b>Cooling Capacity</b>	W	7100
<b>Heating Capacity</b>	W	7800.00
<b>Cooling Power Input</b>	W	1868
<b>Heating Power Input</b>	W	1902
<b>Cooling Current Input</b>	A	8.7
<b>Heating Current Input</b>	A	9
<b>Rated Input</b>	W	2800
<b>Rated Cooling Current</b>	A	12.3
<b>Rated Heating Current</b>	A	16.00
<b>Air Flow Volume</b>	m <sup>3</sup> /h	1250/1100/1000/950/900/850/800/600
<b>Dehumidifying Volume</b>	L/h	2.50
<b>EER</b>	W/W	3.80
<b>COP</b>	W/W	4.10
<b>SEER</b>	-	8.5
<b>SCOP (Average/Warmer/Colder)</b>	-	4.6/5.7/3.6
<b>Application Area</b>	m <sup>2</sup>	23-34

## Indoor Unit Parameters

<b>Indoor Unit Model</b>	-	GWH24BCEXF-K6DNA1A/I
<b>Indoor Unit Product Code</b>	-	CB665N02100
<b>Fan Type</b>	-	Cross-flow
<b>Fan Diameter Length (DXL)</b>	mm	Φ111.5X830
<b>Cooling Speed</b>	r/min	1250/1100/1000/950/900/850/800/650
<b>Heating Speed</b>	r/min	1400/1250/1100/1050/1000/900/850
<b>Fan Motor Power Output</b>	W	70
<b>Fan Motor RLA</b>	A	0.65
<b>Fan Motor Capacitor</b>	μF	/
<b>Evaporator Form</b>	-	Aluminum Fin-copper Tube
<b>Evaporator Pipe Diameter</b>	mm	Φ7
<b>Evaporator Row-fin Gap</b>	mm	2-1.4
<b>Evaporator Coil Length (LXDXW)</b>	mm	840X25.4X381
<b>Swing Motor Model</b>	-	MP24HF/MP35CP
<b>Swing Motor Power Output</b>	W	1.5/2.5
<b>Fuse Current</b>	A	5
<b>Sound Pressure Level</b>	dB (A)	Cooling:48/44/41/40/38/37/35/27 Heating:50/47/43/41/40/38/36
<b>Sound Power Level</b>	dB (A)	Cooling:65/59/56/55/53/51/48/42 Heating:64/62/58/56/55/51/50
<b>Dimension (WXHxD)</b>	mm	1144X333X250
<b>Dimension of Carton Box (LXWXH)</b>	mm	1191X407X327
<b>Dimension of Package (LXWXH)</b>	mm	1196X415X337
<b>Net Weight</b>	kg	16.5
<b>Gross Weight</b>	kg	19.5

## Outdoor Unit Parameters

Outdoor Unit Model	-	GWH24AVEXF-K6DNA1A/O
Outdoor Unit Product Code	-	CB601W00200
Compressor Manufacturer	-	ZHUHAI LANDA COMPRESSOR CO., LTD.
Compressor Model	-	QXFS-A150zX170S
Compressor Oil	-	FW68DA or equivalent
Compressor Type	-	Rotary
Compressor LRA.	A	35.00
Compressor RLA	A	11.35
Compressor Power Input	W	1330
Compressor Overload Protector	-	/
Throttling Method	-	Electron expansion valve
Set Temperature Range	°C	Cooling:16~30 Heating:8~30
Cooling Operation Ambient Temperature Range	°C	-15~50
Heating Operation Ambient Temperature Range	°C	-15~30
Condenser Form	-	Aluminum Fin-copper Tube
Condenser Pipe Diameter	mm	Φ7
Condenser Rows-fin Gap	mm	2-1.4
Condenser Coil Length (LXDXW)	mm	890X38.1X616
Fan Motor Speed	rpm	800
Fan Motor Power Output	W	60
Fan Motor RLA	A	0.8
Fan Motor Capacitor	μF	/
Outdoor Unit Air Flow Volume	m <sup>3</sup> /h	3200
Fan Type	-	Axial-flow

<b>Fan Diameter</b>	mm	Φ520
<b>Defrosting Method</b>	-	Automatic Defrosting
<b>Climate Type</b>	-	T1
<b>Isolation</b>	-	I
<b>Moisture Protection</b>	-	IPX4
<b>Permissible Excessive Operating Pressure for the Discharge Side</b>	MPa	4.3
<b>Permissible Excessive Operating Pressure for the Suction Side</b>	MPa	2.5
<b>Sound Pressure Level</b>	dB (A)	60
<b>Sound Power Level</b>	dB (A)	70
<b>Dimension (WXHxD)</b>	mm	958X660X402
<b>Dimension of Carton Box (LXWXH)</b>	mm	1029X453X715
<b>Dimension of Package (LXWXH)</b>	mm	1032X456X737
<b>Net Weight</b>	kg	42.5
<b>Gross Weight</b>	kg	47
<b>Refrigerant</b>	-	R32
<b>Refrigerant Charge</b>	kg	1.4

## Connection Pipe Parameters

<b>Connection Pipe Length</b>	m	5
<b>Connection Pipe Gas Additional Charge</b>	g/m	40
<b>Outer Diameter Liquid Pipe</b>	inch	1/4"
<b>Outer Diameter Gas Pipe</b>	inch	5/8"
<b>Max Distance Height</b>	m	10
<b>Max Distance Length</b>	m	25

*Note: The connection pipe applies metric diameter.*

*The above data is subject to change without notice. Please refer to the nameplate of the unit.*

# 3.2 Capacity Variation Ratio According to Temperature

09K

Heating operation ambient temperature range is -25°C~30°C.

**Cooling** ▶

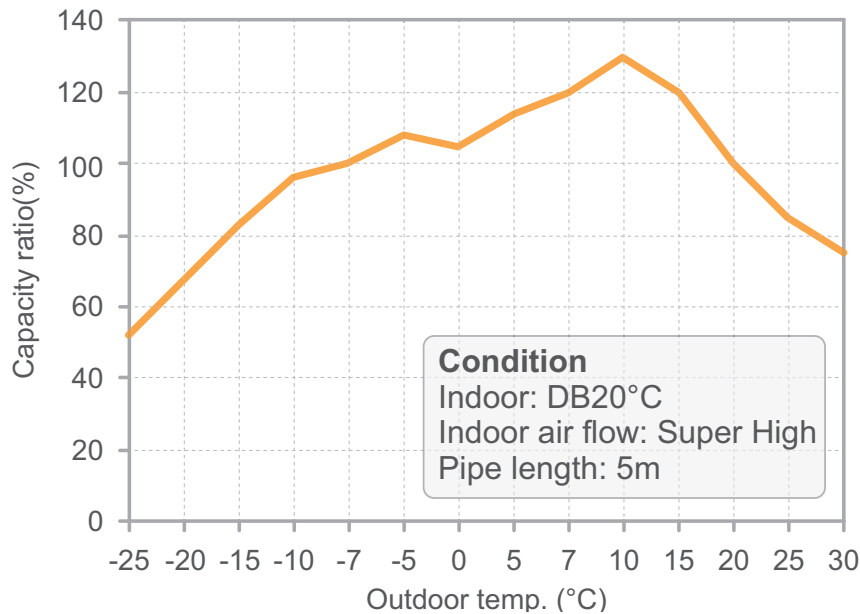
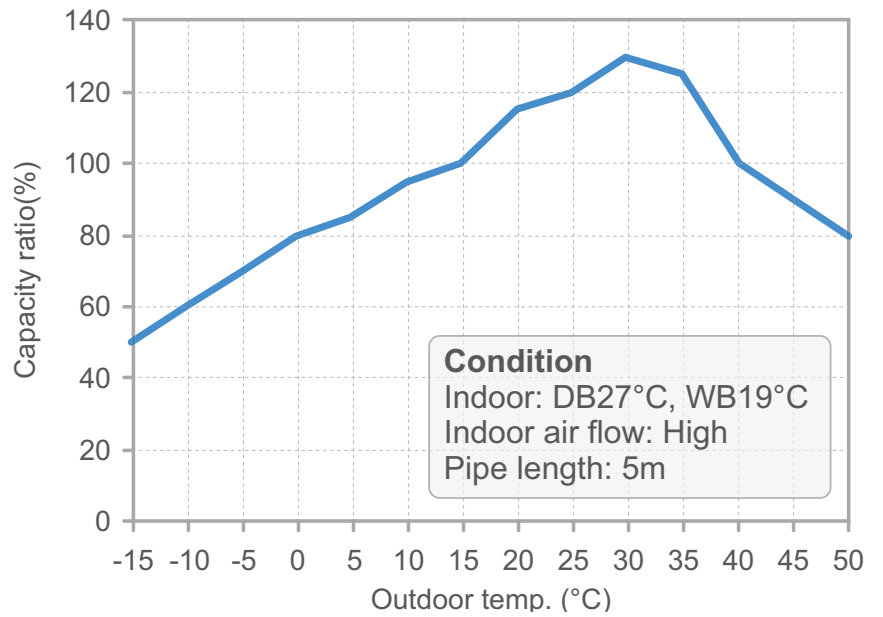

◀ **Heating**

12K

Heating operation ambient temperature range is -25°C~30°C

Cooling ►

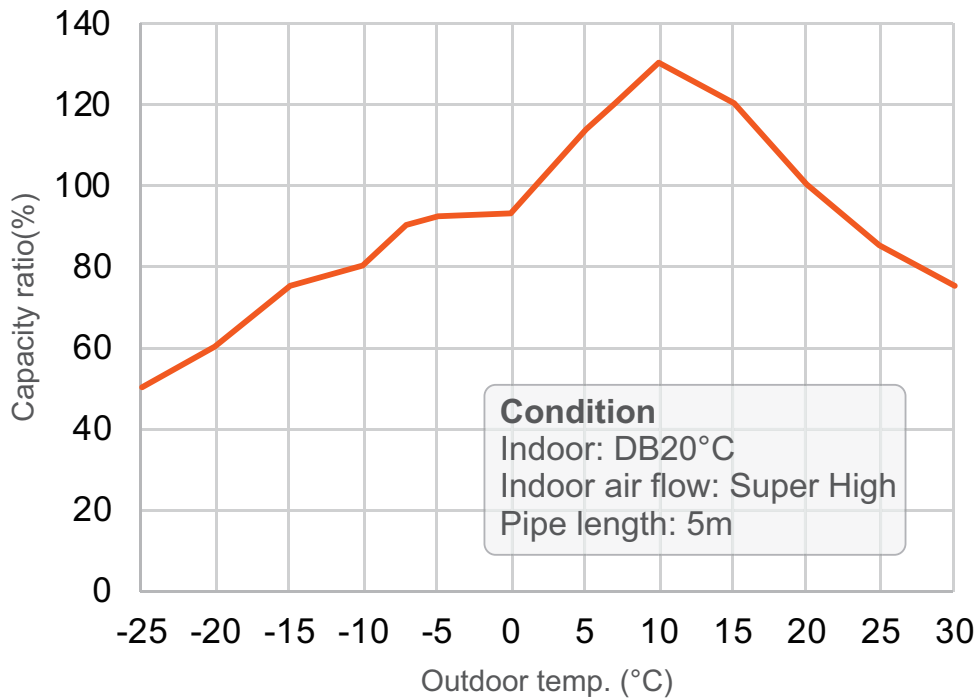
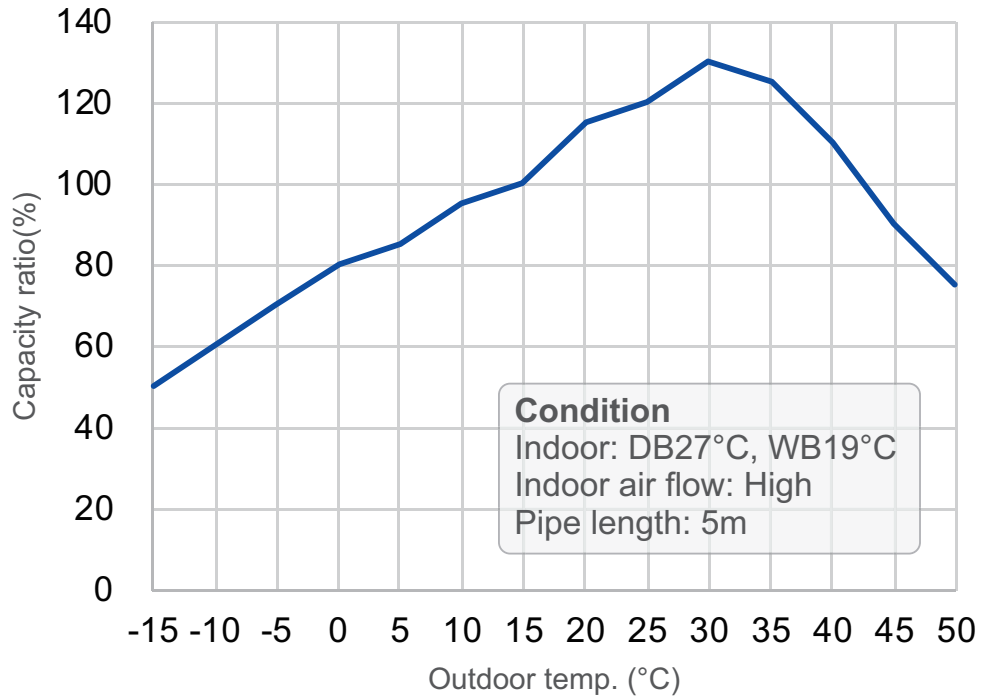

◀ Heating

18K

Heating operation ambient temperature range is -25°C~30°C

Cooling ►

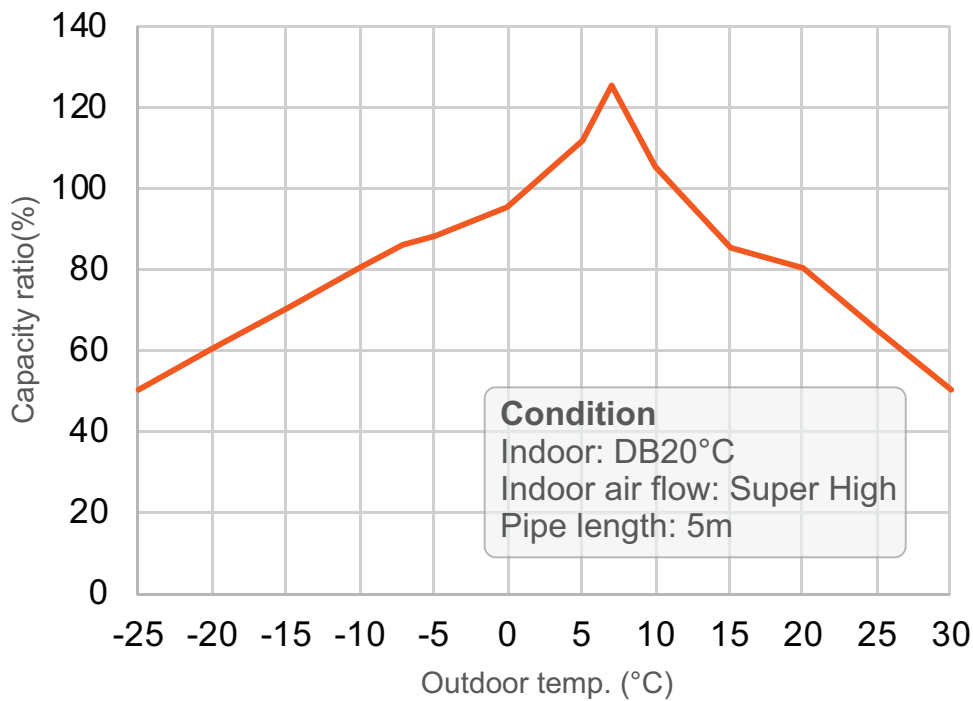
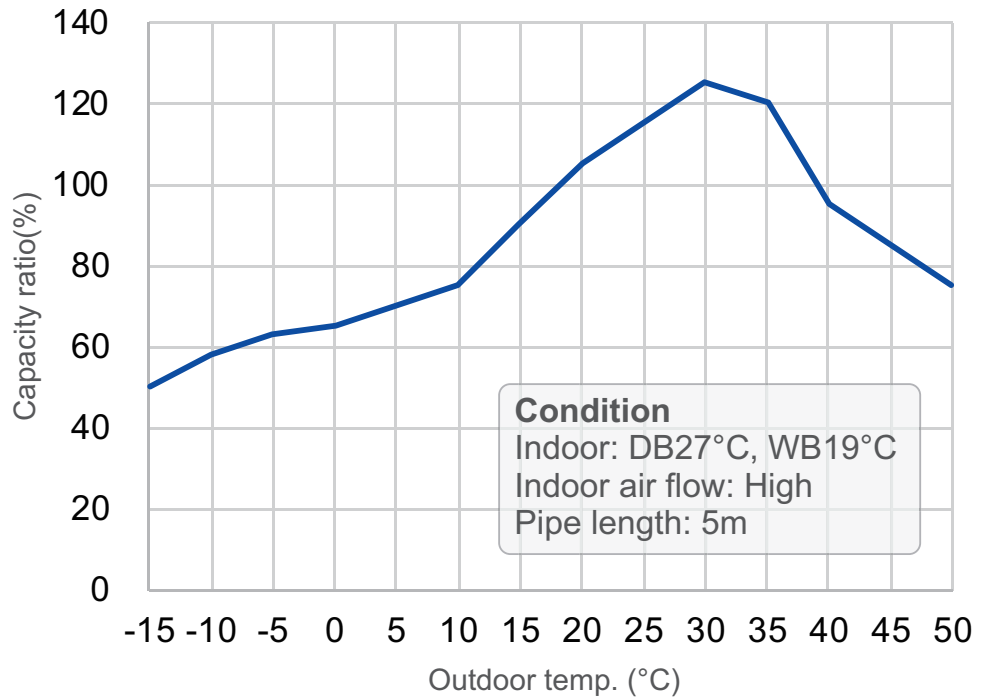

◀ Heating

24K

Heating operation ambient temperature range is -15°C~30°C

Cooling ►

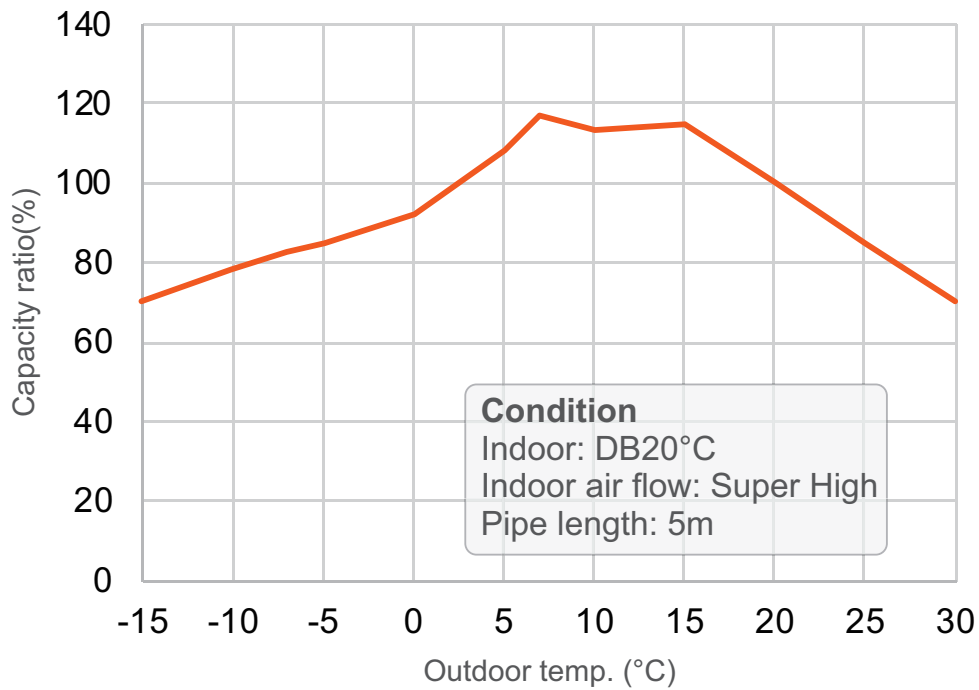
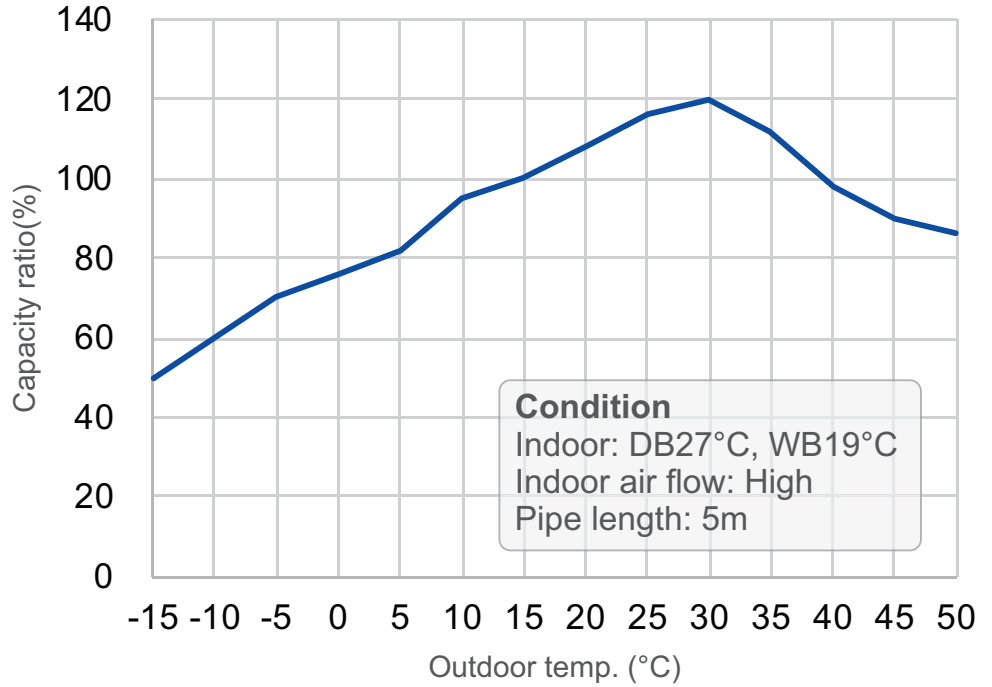

◀ Heating

## 3.3 Cooling and Heating Data Sheet in Rated Frequency

### Cooling

Rated cooling condition (°C) (DB/WB)		Model	Pressure of gas pipe connecting indoor and outdoor unit	Inlet and outlet pipe temperature of heat exchanger		Fan speed of indoor unit	Fan speed of outdoor unit
Indoor	Outdoor			P (MPa)	T1 (°C)		
27/19	35/24	09K	0.8 ~ 1.1	in: 12 out: 15	in: 68 out: 38	Super High	High
27/19	35/24	12K	0.9 ~ 1.1	in: 12 out: 14	in: 75 out: 37	Super High	High
27/19	35/24	18K	0.9 ~ 1.1	in: 12 out: 14	in: 75 out: 37	Super High	High
27/19	35/24	24K	0.9 ~ 1.1	in: 12 out: 14	in: 75 out: 37	Super High	High

### Heating

Rated heating condition (°C) (DB/WB)		Model	Pressure of gas pipe connecting indoor and outdoor unit	Inlet and outlet pipe temperature of heat exchanger		Fan speed of indoor unit	Fan speed of outdoor unit
Indoor	Outdoor			P (MPa)	T1 (°C)		
20/-	7/6	09K	2.8 ~ 3.2	in: 63 out: 35	in: 2 out: 5	Super High	High
20/-	7/6	12K	2.2 ~ 2.4	in: 70 out: 35	in: 2 out: 4	Super High	High
20/-	7/6	18K	2.2 ~ 2.4	in: 70 out: 35	in: 1 out: 5	Super High	High
20/-	7/6	24K	2.2 ~ 2.4	in: 70 out: 35	in: 2 out: 4	Super High	High

### Instruction

T1: Inlet and outlet pipe temperature of evaporator

T2: Inlet and outlet pipe temperature of condenser

P: Pressure at the side of big valve

Connection pipe length: 5 m.

# 4. Outline Dimension Diagram

## 4.1 Indoor Unit

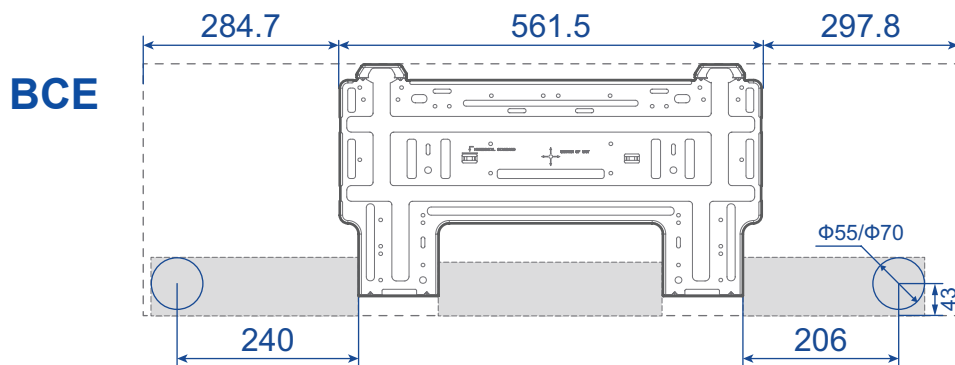
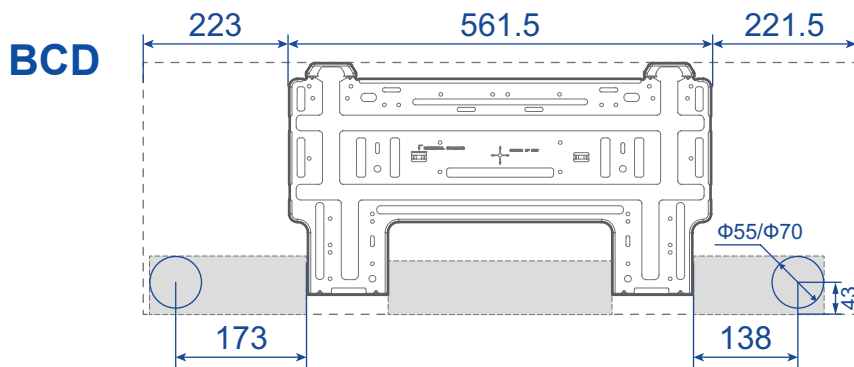
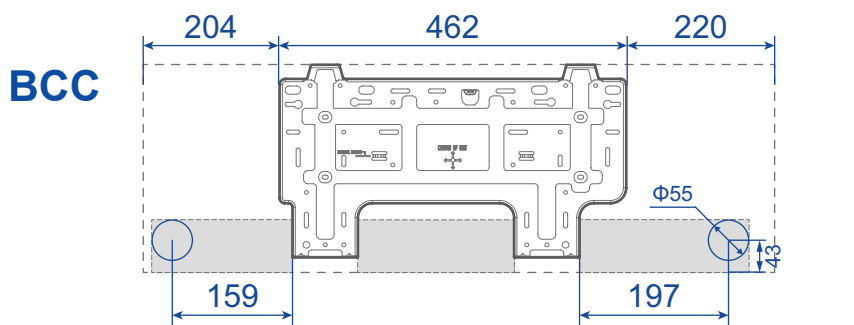
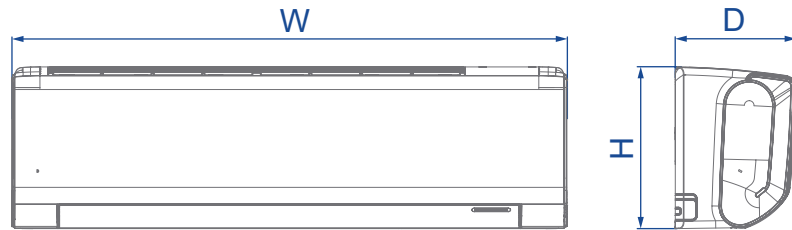

Unit: mm

<b>Indoor Unit Model</b>	<b>W</b>	<b>H</b>	<b>D</b>
BCC	886	276	209
BCD	1006	333	250
BCE	1144	222	250

## 4.2 Outdoor Unit

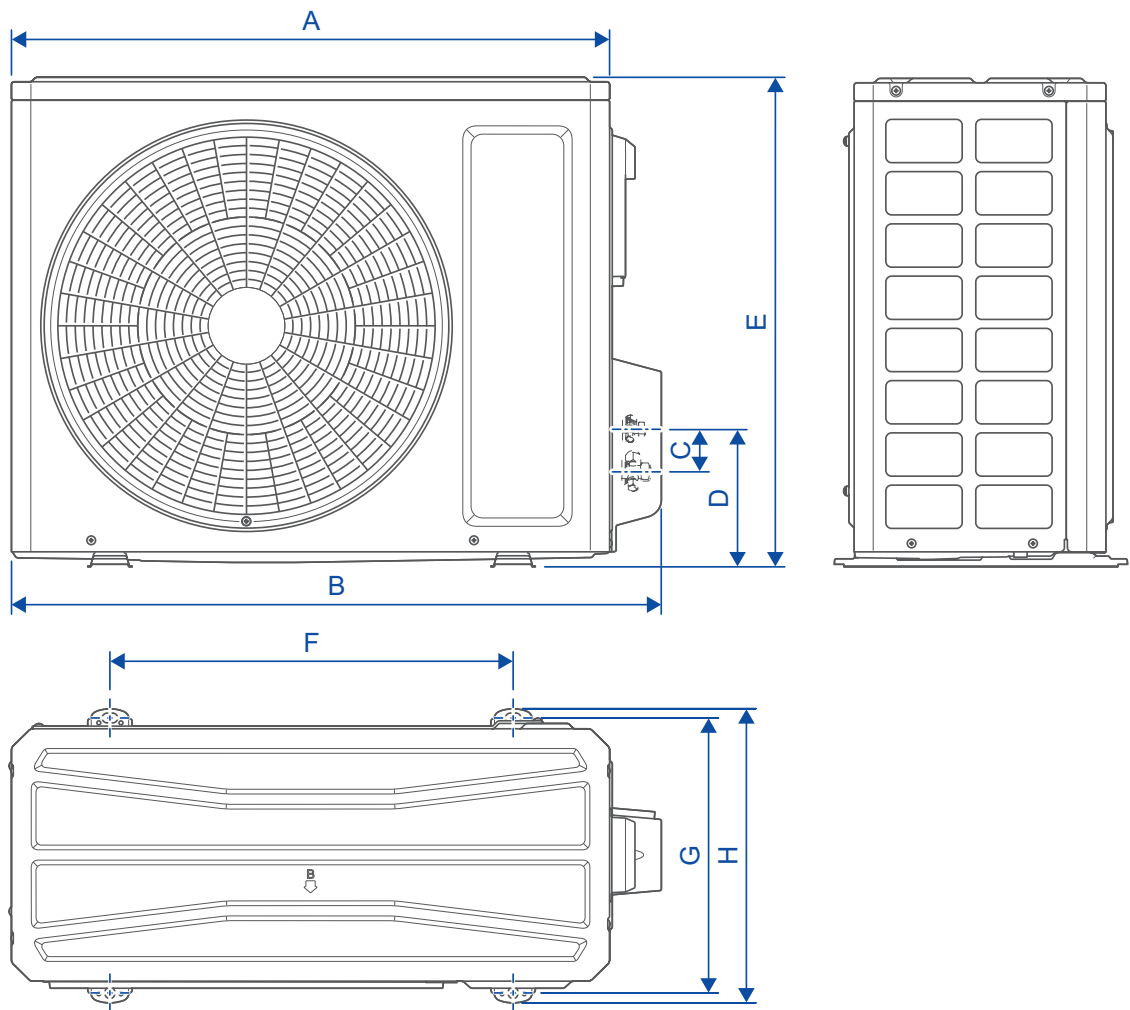

NOTE: The appearance of outdoor unit is for reference only.

Unit: mm

Outdoor Unit Model	A	B	C	D	E	F	G	H
XB	675	732	65	163	555	455	310	330
XD	745	802	65	163	555	513	331	350
XE	805	873	65	164	555	528	349	376
XF	889	958	65	165.6	660	570	371	402

# 5. Refrigerant System Diagram



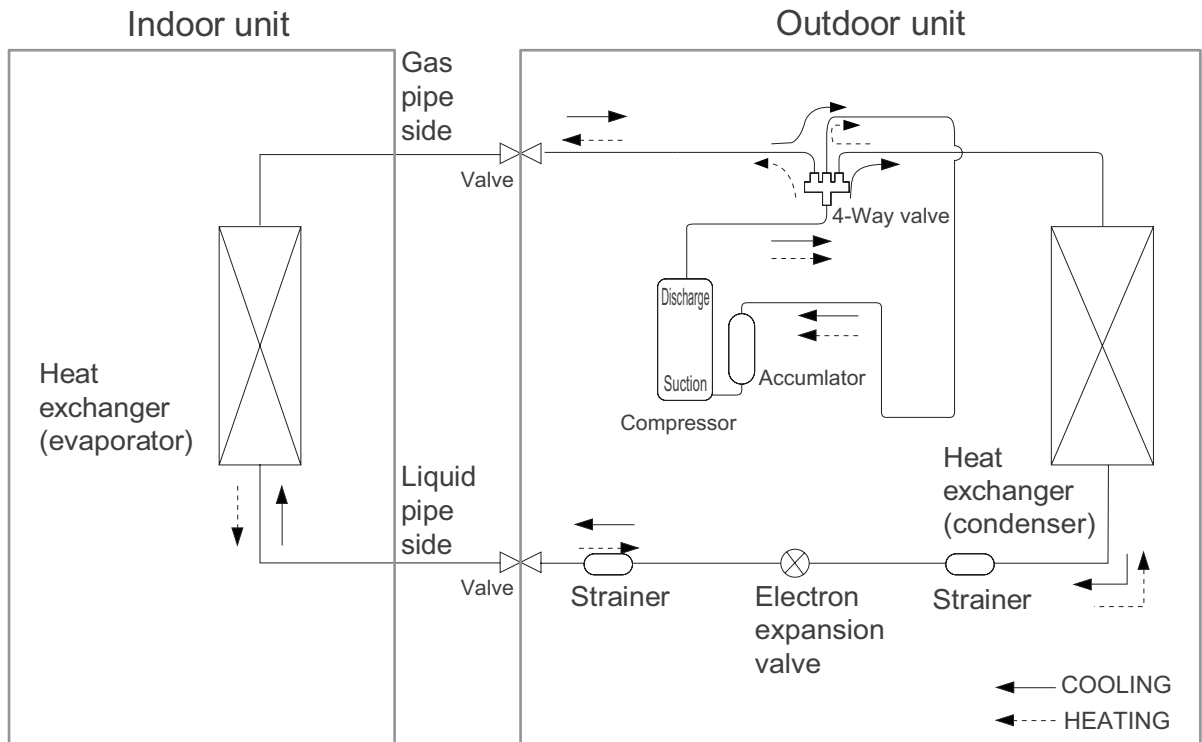









## Heat pump model (Throttling Method: Electron expansion valve)



# 6. Electrical Part

## 6.1 Wiring Diagram

### Instruction

Symbol	Symbol Color	Symbol	Symbol Color
WH	White 	BU	Blue 
YE	Yellow 	BK	Black 
RD	Red 	OG	Orange 
YEGN	Yellow/Green 	GY	Gray 
VT	Violet 	CAP	Jumper cap
GN	Green 	COMP	Compressor
BN	Brown 		Grounding wire

#### NOTE:

Jumper cap is used to determine fan speed and the swing angle of horizontal louver for this model.

## List of Electrical Wiring Diagrams for Indoor Unit

Indoor Unit Model	Indoor Unit Product Code	Wiring Diagram Code for Indoor Unit
GWH09BCCXB-K6DNA1A/I	CB665N01000	600007069708
GWH12BCCXD-K6DNA1D/I	CB665N02200	600007069708
GWH18BCDXE-K6DNA1A/I	CB665N02301	600007067482
GWH24BCEXF-K6DNA1A/I	CB665N02100	600007069708

These wiring diagrams are subject to change without notice; please refer to the one supplied with the unit.

600007069708 ▶

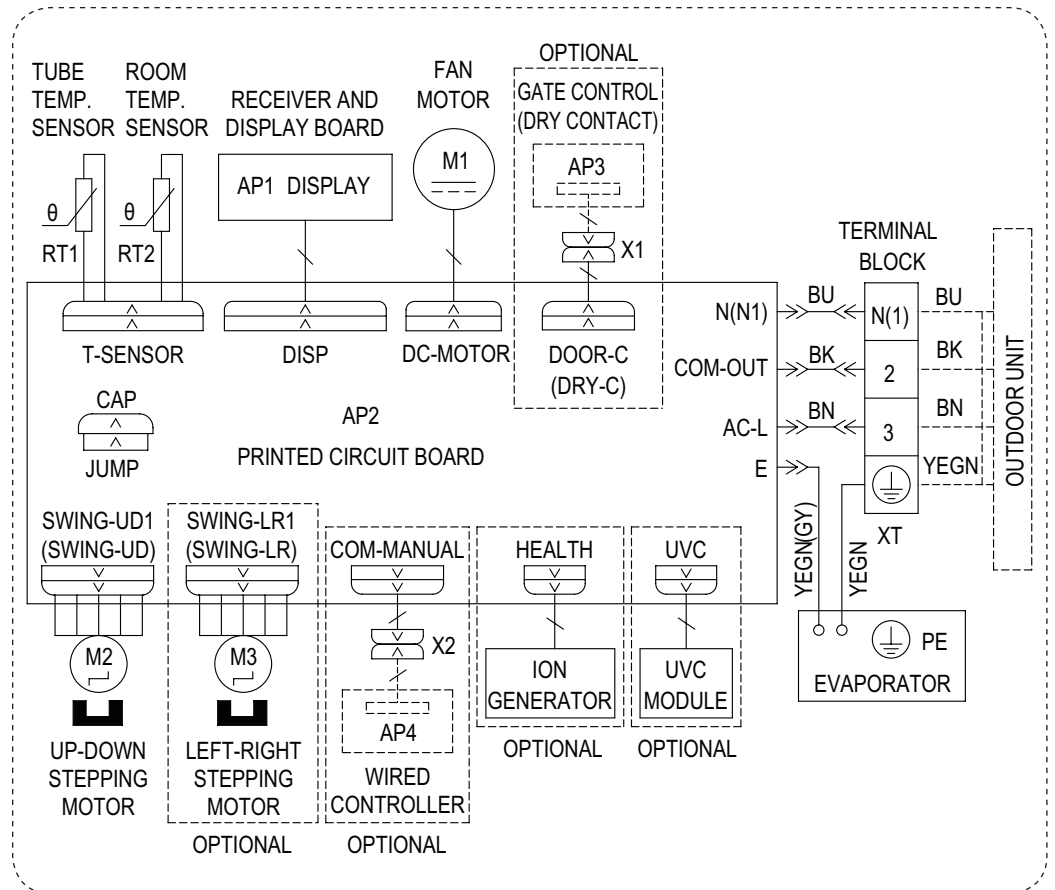

600007067482 ▶

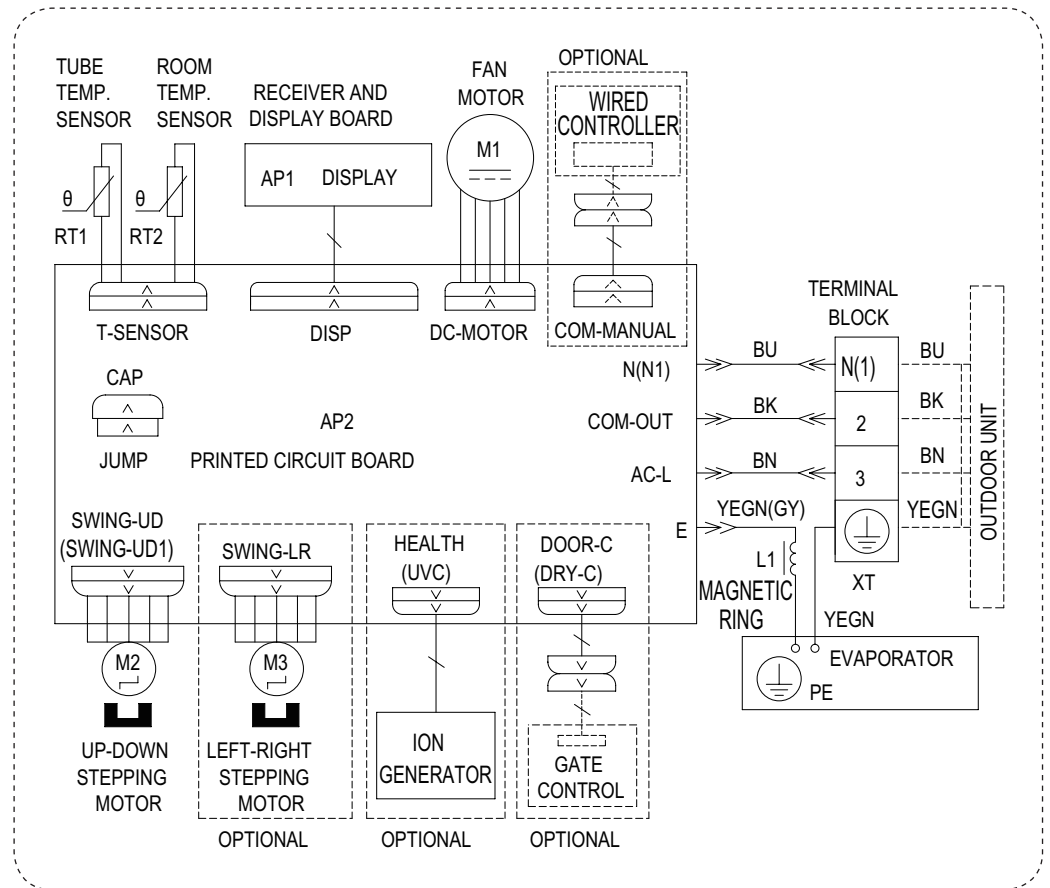

## List of Electrical Wiring Diagrams for Outdoor Unit

Outdoor Unit Model	Outdoor Unit Product Code	Wiring Diagram Code for Outdoor Unit
GWH09ACCXB-K6DNA1G/O	CB497W26500	600007066260
GWH12AWCXD-K6DNA1D/O	CB603W10700	600007066260
GWH18AWDXE-K6DNA4A/O	CB622W03201	600007065005
GWH24AVEXF-K6DNA1A/O	CB601W00200	600007065005

These wiring diagrams are subject to change without notice; please refer to the one supplied with the unit.

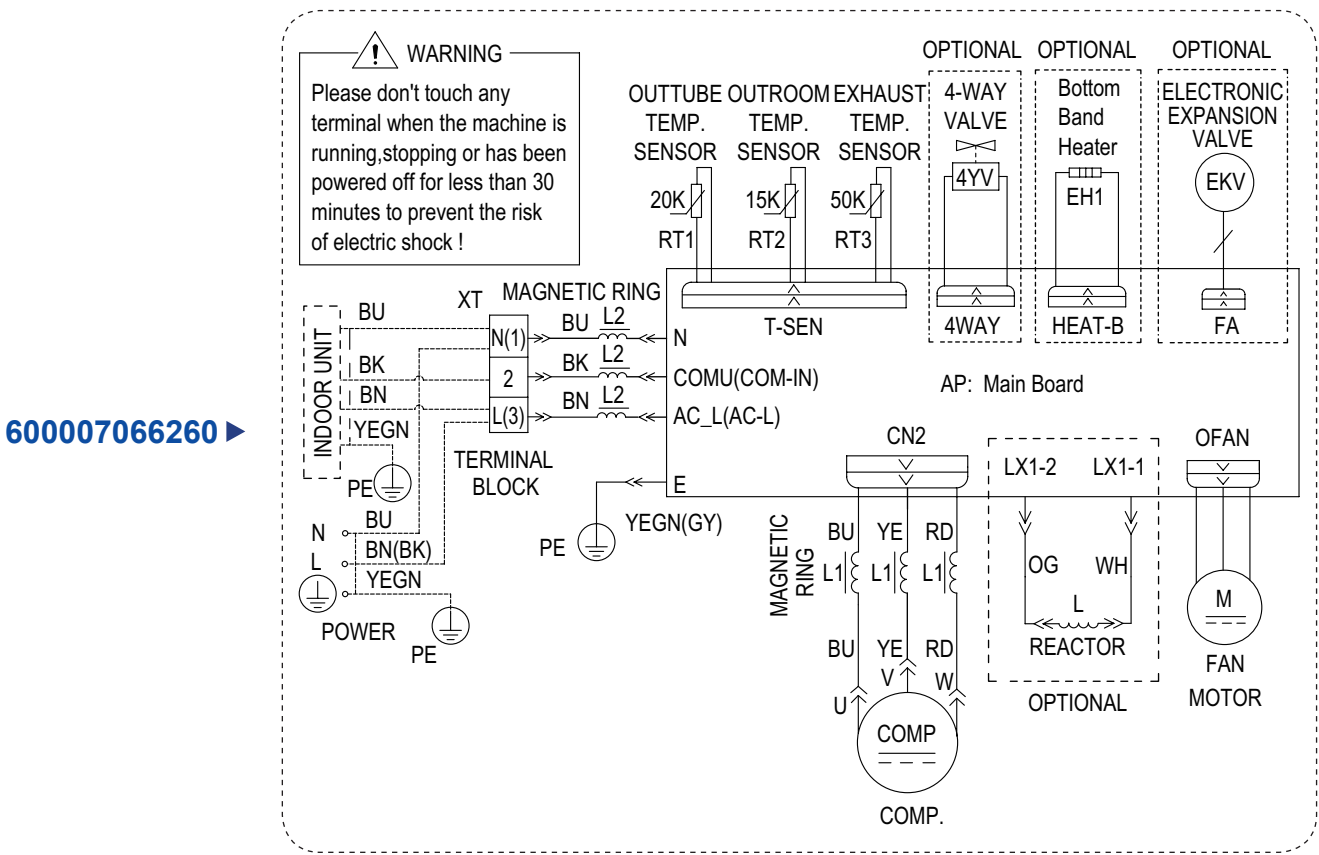

600007065005 ▶

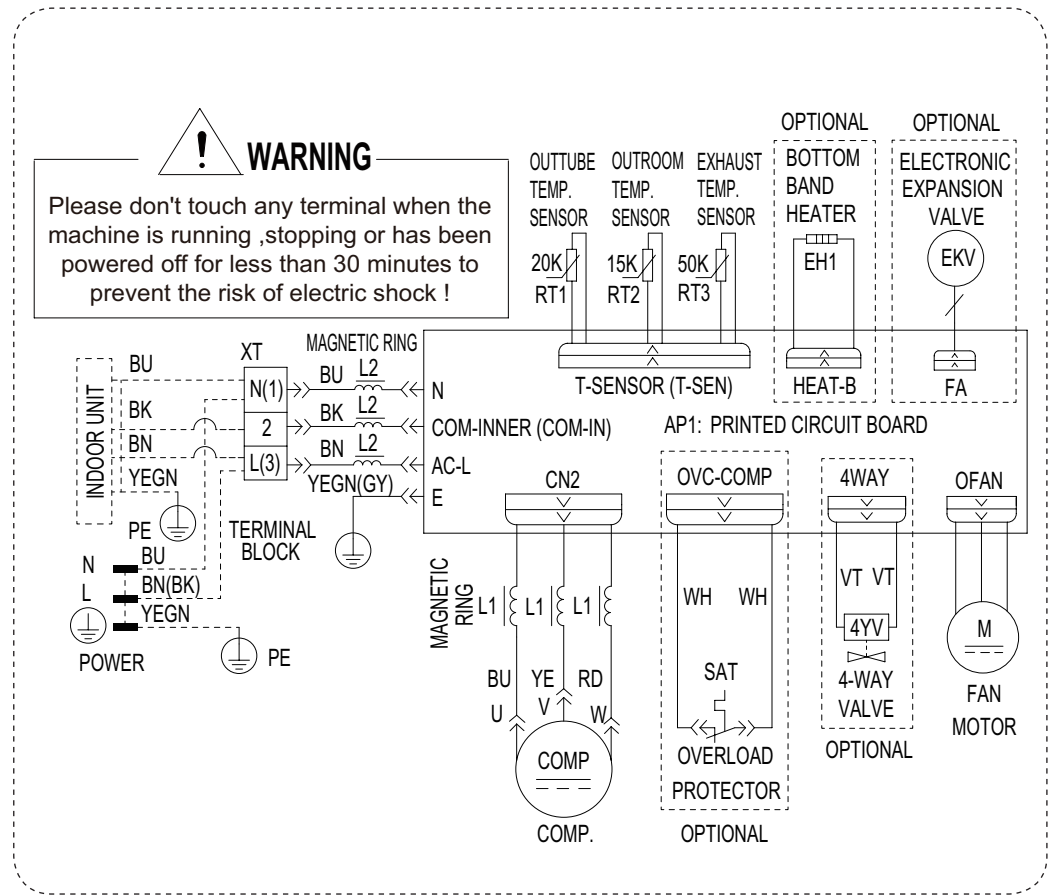

## 6.2 Printed Circuit Board Diagram

### List of Printed Circuit Board Diagrams for Indoor Unit

Indoor Unit Model	Indoor Unit Product Code	Printed Circuit Board Model for Indoor Unit
GWH09BCCXB-K6DNA1A/I	CB665N01000	GRJ869-A7
GWH12BCCXD-K6DNA1D/I	CB665N02200	GRJ869-A7
GWH18BCDXE-K6DNA1A/I	CB665N02301	GRJ869-A7
GWH24BCEXF-K6DNA1A/I	CB665N02100	GRJ869-A7

# GRJ869-A7

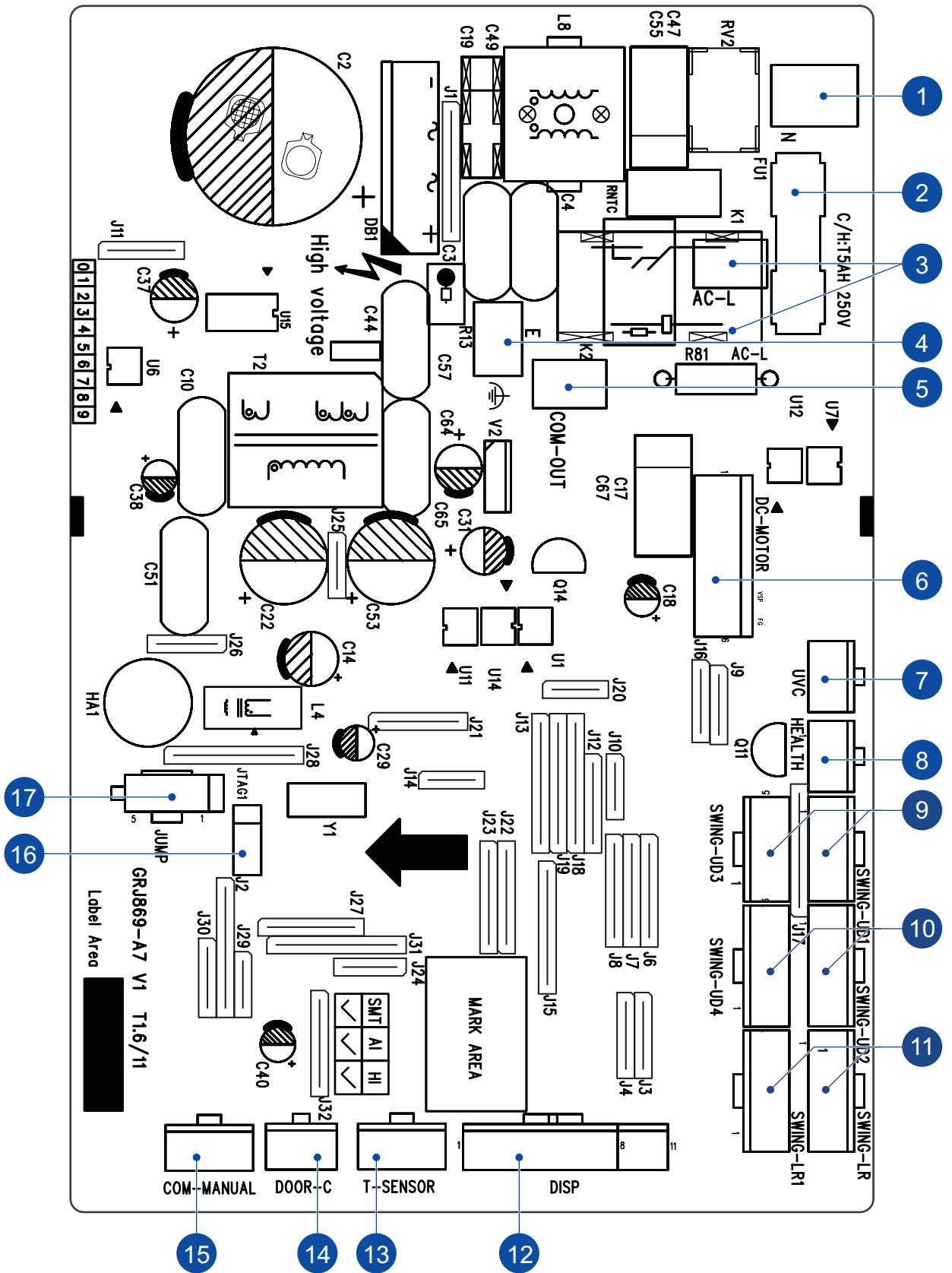

No.	Name
1	Neutral Wire Insertion
2	Fuse
3	Live Wire Insertion
4	Earthing Wire Insertion
5	Communication Wire Insertion
6	Brushless DC Motor Needle Stand
7	Ultraviolet Cleaning Needle Stand
8	Health Function Needle Stand
9	Rod Drive Stepping Motor Needle Stand

No.	Name
10	Up & Down Swing Needle Stand
11	Left & Right Swing Needle Stand
12	Display Board Needle Stand
13	Temperature Sensor Needle Stand
14	Door Control Needle Stand
15	Wired Controller Needle Stand
16	Program Debugging Needle Stand
17	Jumper Needle Stand

**List of Printed Circuit Board Diagrams for Outdoor Unit**

Outdoor Unit Model	Outdoor Unit Product Code	Printed Circuit Board Model for Outdoor Unit
GWH09ACCXB-K6DNA1G/O	CB497W26500	GRJW902-A
GWH12AWCXD-K6DNA1D/O	CB603W10700	GRJW902-A
GWH18AWDXE-K6DNA4A/O	CB622W03201	GRJW918-A3
GWH24AVEXF-K6DNA1A/O	CB601W00200	GRJW924-A8

GRJW902-A

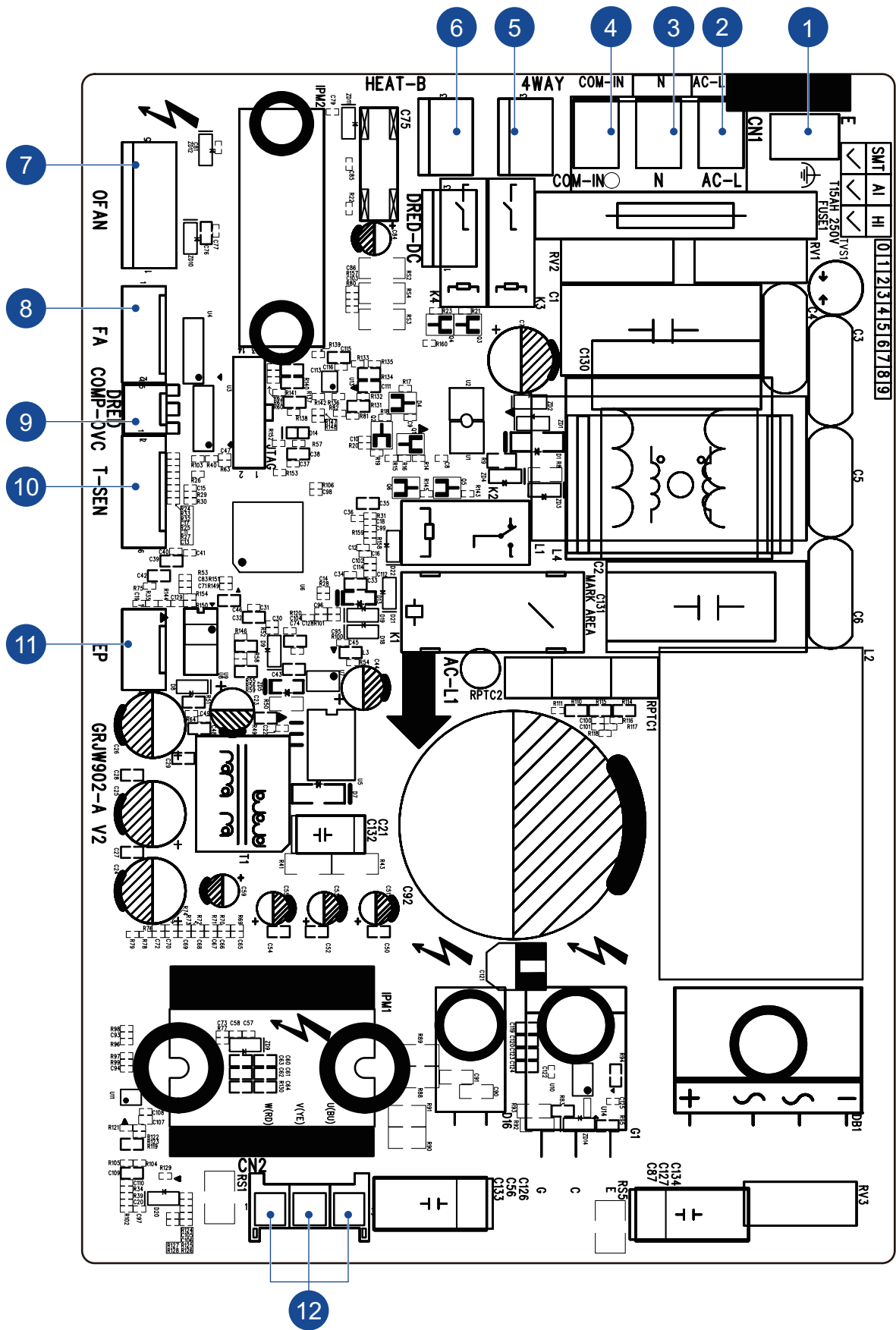

No.	Name
1	Earthing Wire Insertion
2	Live Wire Insertion
3	Neutral Wire Insertion
4	Communication Wire Insertion
5	Four-way Valve Needle Stand
6	Chassis Electric Heating Belt Needle Stand

No.	Name
7	Outdoor Fan Needle Stand
8	Electronic Expansion Valve Needle Stand
9	Compressor Overload Needle Stand
10	Temperature Sensor Needle Stand
11	EOP Flash Drive Needle Stand
12	Compressor Wire Insertion



No.	Name
1	Earthing Wire Insertion
2	Live Wire Insertion
3	Communication Wire Insertion
4	Neutral Wire Insertion
5	Four-way Valve Needle Stand
6	Chassis Electric Heating Belt Needle Stand
7	Electronic Expansion Valve Needle Stand

No.	Name
8	Outdoor Fan Needle Stand
9	Temperature Sensor Needle Stand
10	Compressor Overload Needle Stand
11	Compressor Overload Needle Stand
12	Compressor Wiring terminal for U V W
13	EEP Flash Drive Needle Stand
14	DRED Communication Needle Stand

# GRJW924-A8

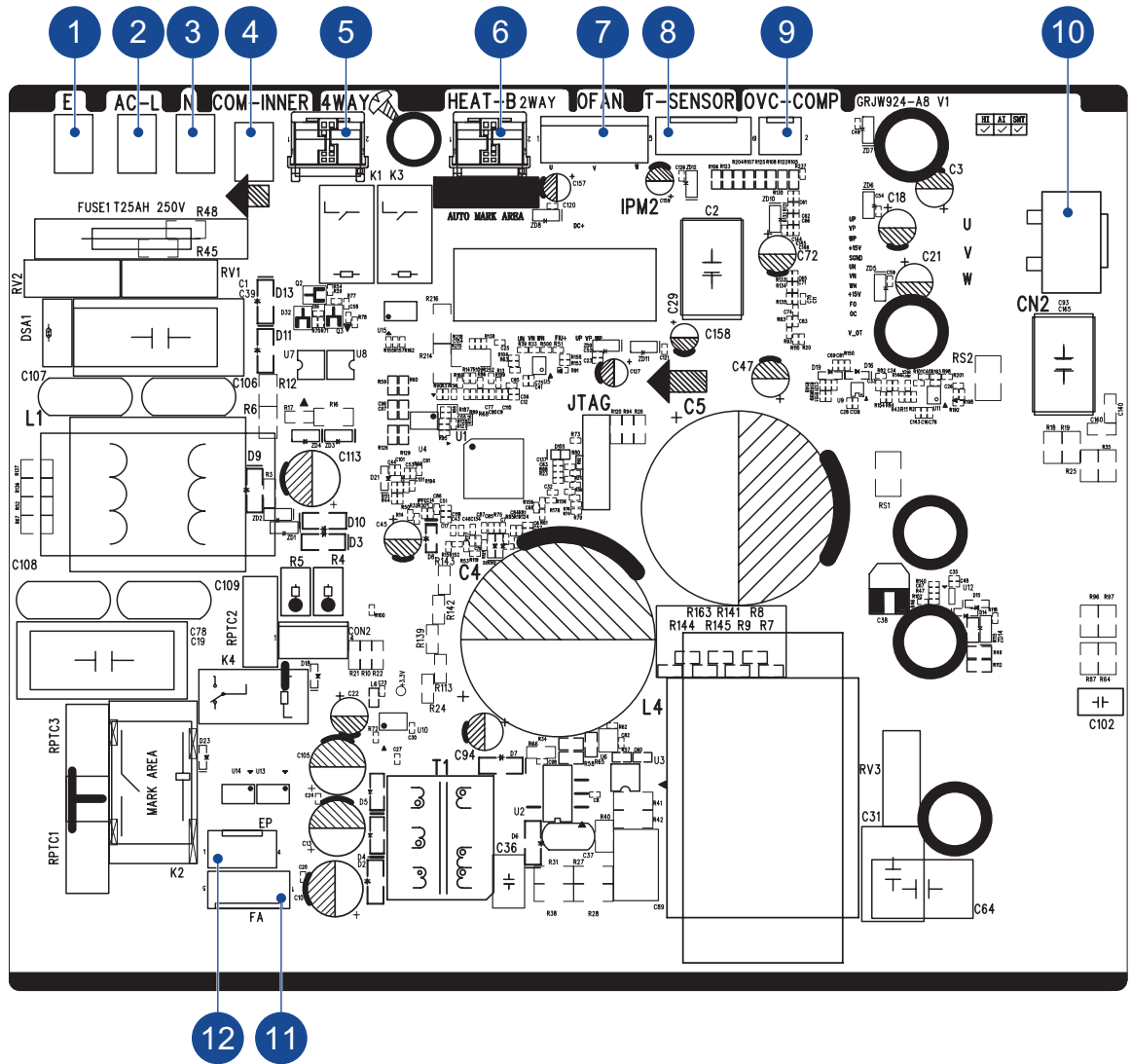

No.	Name
1	Earthing Wire Insertion
2	Live Wire Insertion
3	Neutral Wire Insertion
4	Communication Wire Insertion
5	Four-way Valve Needle Stand
6	Chassis Electric Heating Belt Needle Stand

No.	Name
7	Outdoor Fan Needle Stand
8	Temperature Sensor Needle Stand
9	Compressor Overload Needle Stand
10	Compressor Needle Stand
11	Electronic Expansion Valve Needle Stand
12	EOP Flash Drive Needle Stand

# 7. Function and Control

## 7.1 Remote Controller Introduction for YBE1F



	Quiet	
	Set fan speed	
	Turbo mode	
	Send signal	
Operation mode		Auto mode
		Cool mode
		Dry mode
		Fan mode
		Heat mode
		X-FAN function
	Humidity control	
	Power limiting operation	
	Set temperature	
	Indoor ambient temp.	
	Indoor ambient humidity	
ONOFF	TIMER ON / TIMER OFF	
	Set time	
	Left & right swing	
	Up & down swing	
	Child lock	
	Fast cool	
	Health and UVC functions	
WiFi	WiFi function	
	LED	
	Auto LED	
	I feel	
	Sleep mode	

## Introduction for buttons on remote controller

### NOTE:

- This is a general use remote controller. It could be used for the air conditioner with multifunction. For the functions which the model doesn't have, if press the corresponding button on the remote controller, the unit will keep the original running status.
- After putting through the power, the air conditioner will give out a sound. Power indicator "⏻" is ON. After that, you can operate the air conditioner by using remote controller.
- Under on status, pressing the button on the remote controller, the signal icon "📶" on the display of remote controller will blink once and the air conditioner will give out a "di" sound, which means the signal has been sent to the air conditioner.



### **On/Off button**



Press this button to turn on the unit. Press this button again to turn off the unit.

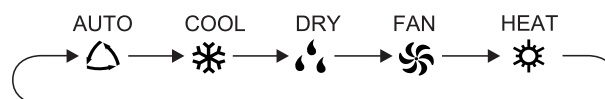

### **Mode button**

Press this button to select your required operation mode.



- When selecting auto mode, air conditioner will operate automatically according to the sensed temperature. Press "Fan" button can adjust fan speed. Press "🌀" / "🌀" button can adjust fan blowing angle.
- After selecting cool mode, air conditioner will operate under cool mode. Press "+" or "-" button to adjust set temperature. Press "Fan" button to adjust fan speed. Press "🌀" / "🌀" button to adjust fan blowing angle.
- When selecting dry mode, the air conditioner operates at low speed under dry mode. Under dry mode, fan speed can't be adjusted. Press "🌀" / "🌀" button to adjust fan blowing angle.
- When selecting fan mode, the air conditioner will only blow fan, no cooling









and no heating. Press "Fan" button to adjust fan speed. Press "  " / "  " button to adjust fan blowing angle.

- When selecting heat mode, the air conditioner operates under heat mode. Press " + " or " - " button to adjust set temperature. Press "Fan" button to adjust fan speed. Press "  " / "  " button to adjust fan blowing angle.



#### NOTE:

- For preventing cold air, after starting up heat mode, indoor unit will delay 1~5 minutes to blow air (Actual delay time depends on indoor ambient temperature).
- Set temperature range from remote controller: 16~30°C(61-86°F).
- This mode indicator is not available for some models.
- Cooling only unit won't receive heat mode signal. If setting heat mode with remote controller, press " On/Off " button can't start up the unit.

### Fan button

This button is used for setting Fan Speed in the sequence that goes from AUTO,  ,  ,  ,  ,  ,  ,  to  , then back to Auto.



- Low speed   ■■ Low-Medium speed   ■■■ Medium speed
- Medium-High speed   ■■■■■ High speed
-  Turbo speed    Quiet speed

#### NOTE:

- It's low fan speed under dry mode.
- X-FAN function Hold fan speed button for 2s in cool or dry mode, the icon "  " is displayed and the indoor fan will continue operation for a few minutes in order to dry the indoor unit even though you have turned off the unit. After energization, X-FAN OFF is defaulted. X-FAN is not available in auto, fan or heat mode.

This function indicates that moisture on evaporator of indoor unit will be blowed after the unit is stopped to avoid mould.

- Having set X-FAN function on: After turning off the unit by pressing " On/ Off " button indoor fan will continue running for a few minutes. at low speed. In this period, hold fan speed button for 2s to stop indoor fan directly.
- Having set X-FAN function off: After turning off the unit by pressing " On/ Off " button, the complete unit will be off directly.

## + / - button

Press " + " or " - " button once increase or decrease set temperature 1°C(°F). Holding " + " or " - " button, 2s later, set temperature on remote controller will change quickly. On releasing button after setting is finished, temperature indicator on indoor unit will change accordingly.



## Wifi button

When the remote controller is OFF, press and hold "Mode" and "Wifi" buttons for about 1s to restore the WiFi module to factory settings and simultaneously enable the WiFi function.

### NOTE:

- This function is only available for some models.



## Health button

Press this button to turn on or turn off the health function and UVC lamp in operation status.

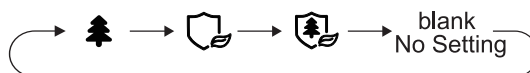

- When selecting " 🌲 " with remote controller, Cold Plasma will be turn on.
- When selecting " 🛡️ " with remote controller, UVC lamp will be turn on.
- When selecting " 🛡️🌲 " with remote controller, Cold Plasma and UVC lamp will be turn on together.

### NOTE:





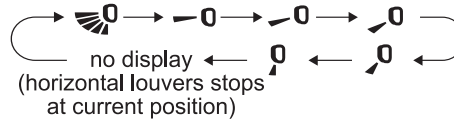

- Health function and UVC lamp are only available for some models.

## **UD-swing button**



Press this button can select up & down swing angle.

Fan blow angle can be selected circularly as below:



- When selecting "  ", air conditioner is blowing fan automatically. Horizontal louver will automatically swing up & down at maximum angle.
- When selecting "  ,  ,  ,  ,  " , air conditioner is blowing fan at fixed position. Horizontal louver will stop at the fixed position.
- Hold "  " button above 2s to set your required swing angle. When reaching your required angle, release the button.

### NOTE:

- Press this button continuously more than 2s, the main unit will swing back and forth from up to down, and then loosen the button, the unit will stop swinging and present position of guide louver will be kept immediately.
- Under swing up and down mode, when the status is switched from off to  , if press this button again 2s later,  status will switch to off status directly; if press this button again within 2s, the change of swing status will also depend on the circulation sequence stated above.

## **Humidity button**

Under cooling mode, press this button can select humidity control with cooling mode, smart dehumidification with cooling mode, and general cooling mode, and they can be set to operate circularly.

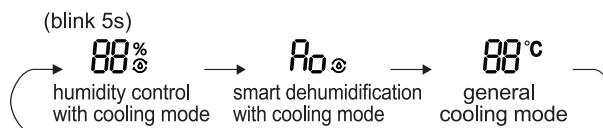

- When humidity control with cooling mode is set, the remote controller will display "  " , and humidity value "88" and "%" icon will blink for 5s; you can

press "+" and "-" buttons to set the humidity value within 5s.

Under humidity control with cooling mode, humidity setting range for the remote controller: 40%-80%.

Temperature can be adjusted under humidity control with cooling mode.

- When smart dehumidification with cooling mode is set, the remote controller will display "⊙" ; the remote controller and indoor unit will display "Ao" for 5 seconds.

Temperature can be adjusted under smart dehumidification with cooling mode.

- The humidity for smart dehumidification is automatically adjusted according to human body comfort; no need to set the humidity manually.

Under dry mode, press this button can select humidity control with dehumidification mode, continuous dehumidification mode, general dehumidification mode, and they can be set to operate circularly.

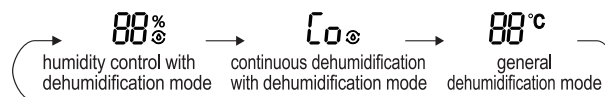

- When humidity control with dehumidification mode is set, the remote controller will display "⊙", "%" and humidity value "88"; you can press "+" and "-" buttons to set the humidity value.

Humidity setting range for the remote controller: 30%-70%.

Temperature can't be adjusted under humidity control with dehumidification mode.

- When continuous dehumidification is set, the remote controller will display "⊙"; the remote controller and indoor unit will display "Co".

Temperature can't be adjusted under continuous dehumidification mode.

- Under continuous dehumidification mode, the unit always works under dehumidification status; no need to set temperature and humidity.

#### NOTE:

- The air conditioner is mainly used for controlling the temperature, while the humidity control is the auxiliary function.

The humidity will be affected by the factors such as indoor and outdoor

environment, degree of indoor sealing and indoor flow.

- When the set humidity is higher than current atmospheric humidity, the set humidity can't be reached.
- If the humidity sensor is with malfunction, humidity setting under cooling mode or dehumidification mode will stop and the unit operates under general cooling mode or dehumidification mode.





## LR-swing button

Press this button can select left & right swing angle.

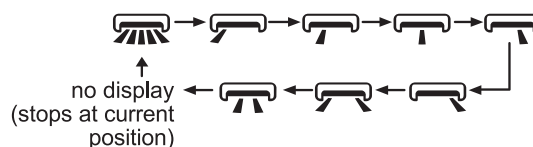
Fan blow angle can be selected circularly as below:



### NOTE:

- Press this button continuously more than 2s, the main unit will swing back and forth from left to right, and then loosen the button, the unit will stop swinging and present position of guide louver will be kept immediately.
- Under swing left and right mode, when the status is switched from off to , if press this button again 2s later,  status will switch to off status directly; if press this button again within 2s, the change of swing status will also depend on the circulation sequence stated above.
- This function only applicable for some models.



## Timer button

- At ON status, press this button once can set TIMER OFF. The character of HOUR and OFF will flash. Press "+" or "-" button within 5s can adjust the time of TIMER OFF. After each pressing of "+" or "-" button, time will increase or decrease half an hour. When holding "+" or "-" button, 2s later, the time will change quickly until to reach to your required time. After that, press "Timer" button to confirm it. The character of HOUR and OFF won't flash again.

Cancel TIMER OFF: Press "Timer" button again under TIMER OFF status.

- At OFF status, press this button once can set TIMER ON. Please refer to TIMER off for detailed operation.



Cancel TIMER ON: Press "Timer" button again under TIMER ON status.

#### **NOTE:**

- Time setting range: 0.5-24 hours.
- Time interval between two operations can't exceed 5s. Otherwise, remote controller will exit the setting status automatically.



### **Sleep button**

Press this button, can select Sleep 1 (  ), Sleep 2 (  ), Sleep 3 (  ) and cancel the Sleep, circulate between these, after electrified, Sleep Cancel is defaulted.

- Sleep 1 is Sleep mode 1, in Cool modes: sleep status after run for one hour, the main unit setting temperature will increase 1 , two hours, setting temperature increased 2 , then the unit will run at this setting temperature; In Heat mode: sleep status after run for one hour, the setting temperature will decrease 1 , two hours, setting temperature will decrease 2 , then the unit will run at this setting temperature.
- Sleep 2 is sleep mode 2, that is air conditioner will run according to the presetting a group of sleep temperature curve.
- Sleep 3 the sleep curve setting under Sleep mode by DIY;
  - (1) Under Sleep 3 mode, press "Health" button for a long time, remote controller enters into user individuation sleep setting status, at this time, the time of remote controller will display "1HOUR", the setting temperature "88" will display the corresponding temperature of last setting sleep curve and blink(The first entering will display according to the initial curve setting value of original factory);
  - (2) Adjust " + " and " - " button, could change the corresponding setting temperature, after adjusted, press "Health" button for confirmation;
  - (3) At this time, 1hour will be automatically increased at the timer position on the remote control, (that are "2HOUR" or "3HOUR" or "8HOUR"),

the place of setting temperature "88" will display the corresponding temperature of last setting sleep curve and blink;

- (4) Repeat the above step (2)~(3) operation, until 8 hours temperature setting finished, sleep,curve setting finished, at this time, the remote controller will resume the original timer display; temperature display will resume to original setting temperature.

- Sleep 3 the sleep curve setting under Sleep mode by DIY could be inquired:

The user could accord to sleep curve setting method to inquire the presetting sleep curve, enter into user individuation sleep setting status, but do not change the temperature, press "Health" button directly for confirmation. Note: In the above presetting or enquiry procedure, if continuously within 10s, there is no button pressed, the sleep curve setting within 10s, there is no button pressed, the sleep curve setting status will be automatically quit and resume to display the original displaying. In the presetting or enquiry procedure, press " On/Off " button, "Mode" button, "Timer" button or "Sleep" button, the sleep curve setting or enquiry status will quit similarly.



### **Light button**

Press this button to control the LED status on the display, the circulation change is as follow:

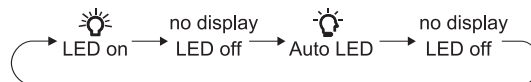

When selecting "  " (Auto LED) with remote controller, LED indicator on indoor unit will adjust the luminance automatically according to the ambient intensity of illumination.

## Function introduction for combination buttons

### *Energy-saving function*



Under cooling mode, press "Mode" and "Timer" buttons simultaneously to start up or turn off energy-saving function. When energy-saving function is started up, "SE" will be shown on remote controller, and air conditioner will adjust the set temperature automatically according to ex-factory setting to reach to the best energy-saving effect.

Press "Mode" and "Timer" buttons simultaneously again to exit energy-saving function.

#### **NOTE:**

- Under energy-saving function, fan speed is defaulted at auto speed and it can't be adjusted.
- Under energy-saving function, set temperature can't be adjusted.
- Sleep function and energy-saving function can't operate at the same time. If energy-saving function has been set under cool mode, press "Sleep" button will cancel energy-saving function. If sleep function has been set under cool mode, start up the energy-saving function will cancel sleep function.

### *Child lock function*

Hold " On/Off " and " - " buttons simultaneously for 3s to turn on or turn off child lock function. When child lock function is on, "  " icon is displayed on remote controller. If you operate the remote controller, the "  " icon will blink three times without sending signal to the unit.

### *Temperature display switchover function*

Under OFF status, hold "Mode" and " - " buttons simultaneously for 3s to switch temperature display between °C and °F.

### *function*

 function is for limiting power of the whole unit. Press "Mode" and "Sleep" buttons simultaneously, the remote controller will circularly display as the following:

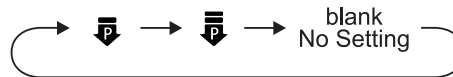

- Maximum power limited under the mode is lower than that of mode.
- If you want to cancel the power limiting function, press "Mode" and "Sleep" buttons simultaneously till the icon in remote controller is not displayed.
- When the remote controller is turned off, power limiting function is cancelled. If you want to activate the function, please repress "Mode" and "Sleep" buttons simultaneously.
- If the current power is lower than the maximum power of mode, then the power will not be limited after entering into such mode.
- For the model with one outdoor unit and two indoor units, if any one of indoor units enters into power limiting function, the outdoor unit will enter into the set limiting power mode of indoor unit; when two indoor units enter into power limiting mode, then the power of outdoor unit will be limited according to the lower power of the two indoor units.

#### NOTE:

- This button is only available for the model with such function.

### *Indoor ambient temperature or humidity display*

By holding " On/Off " and " " buttons simultaneously , you can see indoor ambient temperature or indoor ambient humidity on indoor unit's display. The setting on remote controller is selected circularly as below:



- When selecting " " with remote controller, temperature indicator on indoor unit displays indoor ambient temperature.
- When selecting " " with remote controller, temperature indicator on indoor unit displays indoor ambient humidity.



#### NOTE:

- The ambient humidity value is only for reference. Eg:

If humidity value is "0%", there may be malfunction for the humidity detection board. Please contact local service provider.

- There may be some measuring deviation for humidity detection and photosensitiveness detection.

### **Clean reminder function of filter**

The reminder function is defaulted to be OFF. Hold " On/Off " and "  " buttons simultaneously for 5s to turn it on. The buzzer will give out sound for 0.5s and the dual-8 nixie tube on the display will be on for 3s; Once the reminder function is turned on, when the air conditioner has reached to the set time, the dual-8 nixie tube will flash about 30s when the unit is turned on each time to remind the user to clean the filter; you can turn off this cycle reminder by holding " On/Off " and "  " buttons simultaneously for 5s and then the air conditioner will count time again.

#### **NOTE:**

- Once the reminder function is turned on, only this cycle reminder can be cleared.
- This function is only available for some models.

### **Volume control of IDU Buzzer**

Press "Mode" and "  " buttons simultaneously to reduce the sound level of the indoor unit' buzzer.

#### **NOTE:**

- This function is only available for some models.

### **Fast cool function**

Press " On/Off " and " + " buttons simultaneously under cooling mode can select 25°C(77°F) fast cooling mode, 16°C(61°F) fast cooling mode and normal cooling mode circularly. "  " icon will be displayed on the remote controller under fast cooling mode.

Once it enters into fast cooling mode, the fan speed is auto fan and the set temperature is 25°C(77°F) or 16°C(61°F). At this time, the set temperature flashes to display for 5s. In the flashing period, press " + " or " - " button to adjust the set temperature.

Press "Fan" button to adjust the fan speed. If the set temperature and the fan speed haven't been adjusted during that time, the remote controller and the indoor

unit will operate under current set temperature and fan speed for 20 minutes. 20 minutes later, the set temperature and the fan speed for the remote controller and the indoor unit will turn to the status before quick cooling.

**NOTE:**

- If the set temperature and the fan speed have been adjusted during the operation under fast cooling mode, the unit will exit from the fast cooling mode. Then the indoor unit operates continuously under the adjusted status.
- Fast cooling function is only applicable for some models. If this function is unavailable for this indoor unit, 20 minutes later, the remote controller will turn back to the status before fast cooling. Indoor unit operates continuously according to current status. At this time, status of indoor unit and the display status on the remote controller may be different.
- This function is only available for some models.

### ***Auto clean function***

Under unit off status, hold "Mode" and "  " buttons simultaneously for 5s to turn on or turn off the auto clean function. When the auto clean function is turned on, indoor unit displays "CL" . During the auto clean process of evaporator, the unit will perform fast cooling or fast heating. There may be some noise, which is the sound of flowing liquid or thermal expansion or cold shrinkage. The air conditioner may blow cool or warm air, which is a normal phenomenon. During cleaning process, please make sure the room is well ventilated to avoid affecting the comfort.

**NOTE:**

- The auto clean function can only work under normal ambient temperature. If the room is dusty, clean it once a month; if not, clean it once every three months. After the auto clean function is turned on, you can leave the room. When auto clean is finished, the air conditioner will enter standby status.
- This function is only available for some models.



### ***Night mode***

Under cooling or heating mode, when turning on sleep mode and turn to low speed or quiet notch, the outdoor unit would enter into night mode.

**NOTE:**

- When you feel that the cooling and heating effect is poor, please press "Fan" button to other fan speed or press "Sleep" button to exit the night mode.
- The night mode can only work under normal ambient temperature.
- This function is only available for some models.

## **I FEEL function**

Press "Health" and " + " buttons simultaneously to start I FEEL function and "  " will be displayed on the remote controller. After this function is set, the remote controller will send the detected ambient temperature to the controller and the unit will automatically adjust the indoor temperature according to the detected temperature. Press "Health" and " + " buttons simultaneously again to turn off I FEEL function and "  " will disappear.

- Please put the remote controller near user when this function is set. Do not put the remote controller near the object of high temperature or low temperature in order to avoid detecting inaccurate ambient temperature. When I FEEL function is turned on, the remote controller should be put within the area where indoor unit can receive the signal sent by the remote controller.

## **Two-way ventilation function**

Under turning on, press "Mode" and "Health" buttons simultaneously to start up or turn off two-way ventilation function. When two-way ventilation function is started up, "  " will be shown on remote controller, and the light of the two-way ventilation system is turned on. Fan speed will be adjusted according to the fan speed of air conditioner.

Under turning off, press "Mode" and "Health" buttons simultaneously to start up or turn off two-way ventilation function only. When two-way ventilation function is started up, "  " will be shown on remote controller, and the light of the two-way ventilation system is turned on. Fan speed will be adjusted according to fan button on remote controller.

**NOTE:**

- This function is only available for some models.

## **Circulation Function**

When the unit is running under heating mode, holding "Fan" button for 5s to activate circulation function, " *FR* " icon will be blinked on the remote controller for 3s. When the unit is running under heating mode, holding "Fan" button for 5s to deactivate circulation function, setting temperature will be blinked on the remote controller for 3s.

### **NOTE:**

- Circulation function need to be set again after power failure.
- When matching with the outdoor unit of Free Match, the indoor unit won't execute the circulation function.
- This function is only available for some models.

## Replacement of batteries in remote controller

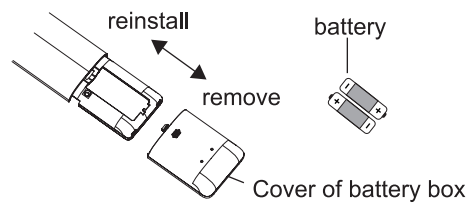

1. Press the back side of remote controller marked with "⊞", as shown in the fig, and then push out the cover of battery box along the arrow direction.
2. Replace two 7# (AAA 1.5V) dry batteries, and make sure the position of "+" polar and "-" polar are correct.
3. Reinstall the cover of battery box.

### NOTICE:

- During operation, point the remote control signal sender at the receiving window on indoor unit.
- The distance between signal sender and receiving window should be no more than 8m, and there should be no obstacles between them.
- Signal may be interfered easily in the room where there is fluorescent lamp or wireless telephone; remote controller should be close to indoor unit during operation.
- Replace new batteries of the same model when replacement is required.
- When you don't use remote controller for a long time, please take out the batteries.
- If the display on remote controller is fuzzy or there's no display, please replace batteries.

## 7.2 Brief Description of Models and Functions

### 1. Main Functions

#### 1.1 Temperature Control

- **Definitions of Temperatures**

The definitions of temperatures are classified as following.

- Room temperature: temperature of lower part of the room
- Set temperature: temperature set by remote controller
- Room thermistor temperature: temperature detected by room temperature thermistor
- Target temperature: temperature determined by microcomputer (Take wall mounted type for example. See the figure below.)

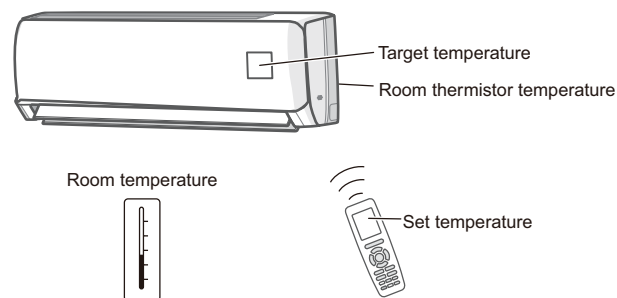

- **Temperature Control**

The temperature of the room is detected by the room temperature thermistor. However, there is a difference between the temperature detected by room temperature thermistor and the temperature of lower part of the room, depending on the type of the indoor unit or installation condition. Practically, the temperature control is done by the target temperature appropriately adjusted for the indoor unit and the temperature detected by room temperature thermistor.

- **Ambient temperature display function**

When the set temperature is set to be displayed by the remote controller, indoor unit displays current set temperature. When the remote control signal is switched to indoor ambient temperature display status from other display status, indoor ambient temperature will be displayed for 3s.

- **I Feel mode**

In order to make room thermistor temperature almost same as the actual operation environment temperature, I Feel mode is designed. After I Feel mode is turned on, the remote controller will send the ambient temperature to the controller of indoor unit intermittently and constantly adjusts the calculated target temperature to make the operation of the air conditioner more suitable for users' needs.

## **1.2 Frequency Principle**

- **Control Parameters**

The frequency of the compressor is controlled by the following 2 parameters:

- The load condition of the operating indoor unit
- The difference between the room thermistor temperature and the target temperature

The target frequency is adapted by additional parameters in the following cases:

- Frequency restrictions
- Initial settings

- **Inverter Features**

The inverter provides the following features:

- The regulating capacity can be changed according to the changes in the outdoor temperature and cooling/heating load.
- Quick heating and quick cooling:

The rotation speed of the compressor is increased when starting the heating (or cooling).

This enables to reach the set temperature quickly.

- Even during extreme cold weather, high capacity is achieved.
- Comfortable air conditioning:

A fine adjustment is integrated to keep the room temperature constant.

- Energy saving heating and cooling:

Once the set temperature is reached, the energy saving operation enables to maintain the room temperature at low power.

- **Frequency Limits**

The following functions regulate the maximum frequency:

- Discharge pipe temperature control. Refer to 3.4.
- Input current control. Refer to 3.5.
- Freeze-up protection control. Refer to 3.6.
- Heating peak-cut control. Refer to 3.7.

### **1.3 Airflow Direction Control**

- **Power-Airflow Flap**

The flap sends a large volume of air downward to the floor and provides an optimum control in cooling, dry, and heating operation.

- Cooling/Dry

During cooling or dry operation, the flap directs airflow horizontal. Then, cool air can be blown far and distributed all over the room.

- Heating

During heating operation, the flap directs airflow downward to spread the warm air to the entire room.

- **Wide-Angle Louvers**

The louvers, made of synthetic resin, provide a wide range of airflow that guarantees comfortable air distribution.

- **Auto swing angle range**

After setting auto swing function, the air guide louver automatically swing among L1-A1-B1-C1-D under cooling mode. Under heating mode, the air louver automatically swing among L-A-B-C-D. As for different unit, the angle value is different for L1, A1, B1, C1, D1, L, A, B, C and D.

- **COMFORT AIRFLOW Operation**

The flaps are controlled not to blow the air directly at the people in the room.

The airflow will be in the upward direction while in cooling operation and

in the downward direction while in heating operation, which will provide a comfortable wind that will not come in direct contact with people.

When heating mode is just started up, the air guide louver will swing to the position where the cold air won't blow to the people for cold air prevention. When entering into defrosting stage, the air guide louver will also swing to the position where the cold air won't blow to the people.

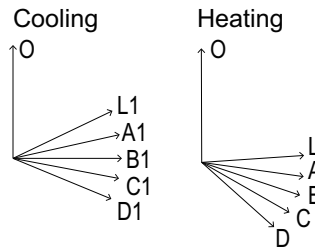

## 1.4 Fan Speed Control for Indoor Unit

- **Fan**

Indoor fan operates at the fan speed set by the remote controller.

- **AUTO**

The fan speed is regulated according to the indoor heat exchanger temperature and the difference between the room thermistor temperature and the target temperature. When the set temperature is quite different from the room temperature, it indicates there is high demand for cooling and heating. Indoor fan will operate at the high fan speed. When temperature difference between the set temperature and the room temperature is not big, it indicates there is medium demand for cooling and heating. Indoor fan will operate at the medium fan speed. When temperature difference between the set temperature and the room temperature is small, it indicates there is small demand for cooling and heating. Indoor fan will operate at the low fan speed.

## 1.5 Program Dry Operation

Program dry operation removes humidity while preventing the room temperature from lowering. Since the microcomputer controls both the temperature and airflow rate, the temperature adjustment and FAN setting buttons are inoperable.

## 1.6 X-fan Function

When the unit is under cooling or dry mode, the X-fan function can be turned on by pressing the "X-fan" button on the remote controller (if there is X-fan button on

the remote controller). If X-fan function is turned, when the unit is turned off by the remote controller, the indoor fan will still operate for several minutes at the low fan speed. When the unit is operating under X-fan mode, the complete unit will be turned off immediately if use the remote controller to turn off the X-fan function.

## 1.7 Automatic Operation

- **Automatic Cooling/Heating Function**

When the automatic operation is selected with the remote controller, the microcomputer automatically determines the operation mode as cooling or heating according to the room temperature and the set temperature at start-up.

The unit automatically switches the operation mode to maintain the room temperature at the set temperature.

## 1.8 NIGHT SET Mode

- **Some models are only with good sleep mode.**

NIGHT SET Mode continues operation at the target temperature for the first one hour, then automatically raises the target temperature slightly in the case of cooling, or lowers it slightly in the case of heating. This prevents excessive cooling in summer and excessive heating in winter to ensure comfortable sleeping conditions, and also conserves electricity.

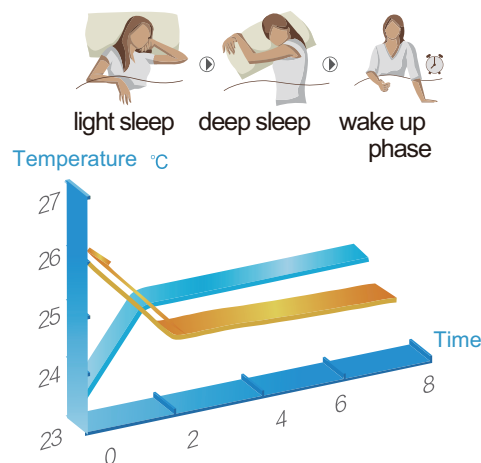

- **Sound sleep mode**

set temperature is close to body temperature and will adjust automatically and intelligently.

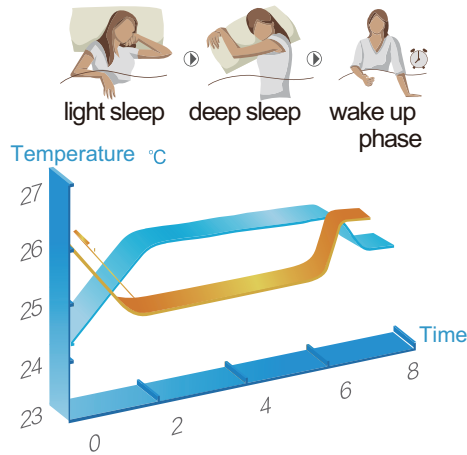

• **Good sleep mode**

before you get up, set temperature will decrease or increase automatically to refresh you in the morning.

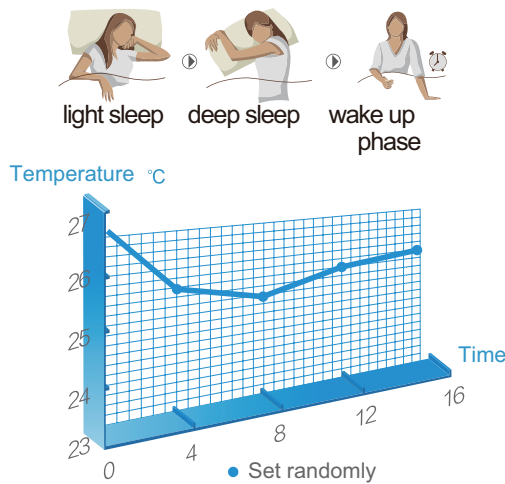

• **DIY mode**

you can set temperature curve and sleep time as you like.

### 1.9 ECONO Operation

ECONO operation reduces the maximum operating current and the power consumption.

This operation is particularly convenient for energy-saving. It is also a major bonus when breaker capacity does not allow the use of multiple electrical devices and air conditioners. This function can be set only in cooling mode.

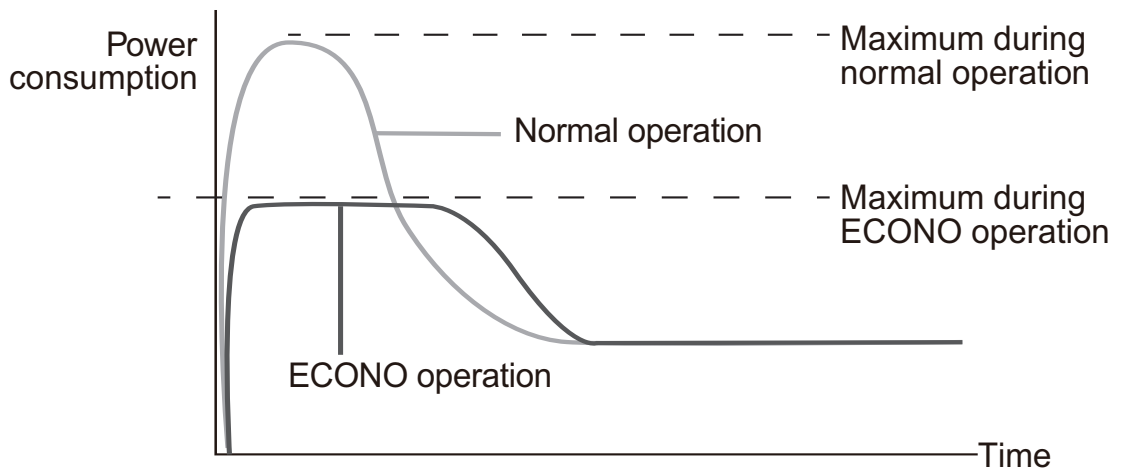

## 1.10 Timer Function

The timing function of the complete unit is divided into general timer and clock timer, which can be switched by equipping different remote controls.

### 1. General timer function

- Timer ON function:

Timer ON time can be set under unit off status (power is put through) through the remote control. Timer setting range is 0.5~24h in 30min increments.

- Timer OFF function:

Timer OFF time can be set under unit on status through the remote control. Timer setting range is 0.5~24h in 30min increments.

### 2. Clock timer function

Unit on or unit off at a certain time can be set through the remote control with the precision of 1min.

- Timer ON function:

Timer ON time can be set under unit off status (power is put through) through the remote control. When the set timer ON time is reached, the unit will start to run according to previous setting mode. If timer ON is set during operation of the unit, the unit will continue to operate.

- Timer OFF function:

Timer OFF time can be set under unit on status through the remote control. When the set timer OFF time is reached, the unit will stop operation. If timer OFF is set under unit off status, the system will keep standby status.

## 1.11 Refrigerant Recycling Function

Under cooling mode, the unit will enter the refrigerant recycling mode after receiving the command set by the remote control, and the compressor will run at high frequency for refrigerant recycling.

Control measure: within 5min of energizing, turning on the unit in cooling mode with set temperature of 16°C, continuously press light button for 3 times within 3s to enter refrigerant recycling mode.  $F_{\square}$  will be displayed and refrigerant recycling mode will be sent to the outdoor unit.

## 1.12 8°C Heating Mode

Under heating mode, the set temperature is 8°C and indoor display board displays the set temperature 8°C (according to the  $\beta$  pattern displayed in the lower position and not displayed in the higher position). 46 is displayed in Fahrenheit temperature and the unit is in heating operation.

Control measures: according to the difference between the set temperature and the ambient temperature, the indoor fan chooses to run at different speeds.

1. When the compressor is running, the fan speed is adjusted according to the following automatic speed mode.

When  $(T_{amb.} - \Delta T_{supplementary}) \leq (T_{set} - 2^{\circ}\text{C})$ , the indoor fan runs at high speed;

When  $(T_{set} - 2^{\circ}\text{C}) < (T_{amb.} - \Delta T_{supplementary}) < T_{set}$ , the indoor fan runs at medium speed;

When  $(T_{amb.} - \Delta T_{supplementary}) \geq T_{set}$ , the indoor fan runs at low speed;

2. High speed, medium speed and low speed are switched, and a minimum running time of 3 minutes and 30 seconds must be ensured.

### 1.13 Comfortable Energy-saving Mode

Under cooling mode, when the comfortable energy-saving command is received from the remote control, the controller enters the comfortable energy-saving mode; the indoor unit executes set temperature of 27°C, and the horizontal louver turns to the angle that can blow cold air directly to the human body.

Control measures: under this mode, when the compressor is running, the fan speed is adjusted according to the automatic fan speed mode under the condition of energy-saving mode (see below); when the compressor stops, the indoor fan runs at a low speed.

1. When the compressor is running, the fan speed is adjusted according to the following automatic speed mode.

When  $(T_{amb.} - \Delta T_{supplementary}) \leq (T_{set} - 2^{\circ}\text{C})$ , the indoor fan runs at low speed;

When  $(T_{set} - 2^{\circ}\text{C}) < (T_{amb.} - \Delta T_{supplementary}) < T_{set}$ , the indoor fan runs at medium speed;

When  $(T_{amb.} - \Delta T_{supplementary}) \geq T_{set}$ , the indoor fan runs at high speed;

2. High speed, medium speed and low speed are switched, and a minimum running time of 3 minutes and 30 seconds must be ensured.

### 1.14 Mild Dry Function

For the air conditioner with this function, if the indoor unit receives the normal humidity value sent by WiFi (not 0), the "Mild Dry" sign and humidity value will be sent to the outdoor unit; if the indoor unit doesn't receive the humidity value of the WiFi board, the "Without Mild Dry" sign will be sent to the outdoor unit;

After energization, as long as the normal humidity value sent by WiFi (not 0) is received, it is considered that there is a humidity sensor;

If the humidity sensor error or the WiFi communication error sent by the WiFi detection board is received and there is a humidity sensor, the humidity sensor error sign will be sent to the outdoor unit;

## **1.15 New Access Control Function**

### **1. Switch control function**

Customers are required to install the dry contact and wire controller by themselves to detect whether there is anyone in the room through the dry contact. If there is anyone (detection signal is high level), it will be handled according to the last remote control or timer. If there is no one (detection signal is low level), it will keep shutdown or shut down after operating for 6 minutes;

### **2. Shutdown error output function**

When the unit has a shutdown error and the error is displayed, the main chip control port outputs low electrical level.

## **1.16 FastCool Function**

Under cooling mode, when the FastCool command sent by the remote control is received, the controller enters the FastCool mode, and starts 20min timing. The running status is according to the remote control command. After 20 minutes, the temperature and fan speed will return to the cooling state before entering FastCool (if the cooling mode has not been run before entering FastCool after energization, it will run according to the automatic fan mode of 25°C); if the unit has ever been controlled by the APP, wired controller or auto button, FastCool mode will be exited.

## 1.17 Other Functions

### 1. Auto clean function

When the remote control is under unit off status, holding the MODE button and FAN button for 5 seconds at the same time, the remote control displays [L], and the unit enters the auto clean mode.

The auto clean function of the indoor unit includes preparation stage, condensing stage, frosting stage, defrosting and sterilization stage.

If the outer unit has auto clean function, the outdoor unit will enter the auto clean function after cleaning of indoor unit is completed.

The auto clean function of outdoor unit includes condensing stage, frosting stage, defrosting and deducting stage. If the outdoor unit doesn't have auto clean function, the indoor fan will exit the "auto clean" mode directly and operates according to the remote control setting.

#### NOTE:

Auto clean function will be entered at a certain ambient temperature. For the heat pump models, auto clean of the indoor unit includes high-temperature sterilization stage. For cooling only models, there is no such sterilization stage.

### 2. Auto preheating function

Under standby status, after the compressor stops for 10 minutes, if  $T_{outdoor\ amb.} \leq -5^{\circ}\text{C}$  and  $T_{discharge} \leq -5^{\circ}\text{C}$ , the compressor coil starts preheating.

During the coil preheating period, if  $T_{discharge} > 0^{\circ}\text{C}$ , the compressor stops preheating. After the compressor stops preheating, if  $T_{discharge} \leq -5^{\circ}\text{C}$  and the outdoor ambient temperature meets the conditions for the compressor coil auto preheating control, it will enter the compressor coil auto preheating control again.

### 3. Buzzer

When the controller is energized or receives remote control signal, auto button and other valid control signals, the buzzer will give out a beep.

If the weak tone signal of buzzer is set by the remote control, the buzzer will give out weak tone. If the normal tone signal of buzzer is set by the remote control, the buzzer will give out normal tone.

#### **4. Auto button**

If this button is pressed under unit off status, the complete unit will operate in auto mode and IDU fan will operate at auto speed and swing function will be turned on. If this button is pressed under unit on status, the unit will be turned off.

#### **5. Memory function**

If a power failure (including one for just a moment) occurs during the operation, the operation restarts automatically when the power is restored in the same condition as before the power failure.

## ***2. Thermistor Functions***

### ***2.1 Outdoor Heat Exchanger Thermistor***

In cooling operation, the outdoor heat exchanger thermistor is used for high temperature protection.

In heating operation, the outdoor heat exchanger thermistor is used for defrost control.

### ***2.2 Discharge Pipe Thermistor***

The discharge pipe thermistor is used for controlling discharge pipe temperature. If the discharge pipe temperature (used in place of the inner temperature of the compressor) rises abnormally, the operating frequency becomes lower.

The discharge pipe thermistor is used for detecting disconnection of the discharge pipe thermistor.

### ***2.3 Indoor Heat Exchanger Thermistor***

In cooling operation, the indoor heat exchanger thermistor is used for frozen-preventing protection high temperature protection.

In heating operation, the indoor heat exchanger thermistor is used for high temperature protection.

## 3. Control Specification

### 3.1 Frequency Control

- **Delay protection function of compressor**

Under various modes, once the compressor is turned on, it should be operated for at least 7 minutes before the compressor can be stopped (excluding fault protection and the situation that the compressor needs to be stopped during mode conversion, see the rear fault protection for details); Once the compressor is stopped, it can only be started after a delay of 3 minutes (except for heating oil return and defrosting).

- **Working range of compressor frequency**

**(Parameters to be confirmed by experiments, related to system and compressor drive)**

(1) Upper and lower limit frequency of cooling mode (Specific parameters are subject to EPPROM)

No.	1	2	3	4	5	6	7	8
T <sub>outdoor amb.</sub>	< -16	[-16,10)	[-10,-5)	[-5,0)	[0,5)	[5,10)	[10,16)	[16,25)
Lower limit frequency	a1	a2	a3	a4	a5	a6	a7	a8
Upper limit frequency	b1	b2	b3	b4	b5	b6	b7	b8

No.	9	10	11	12	13	14	15
T <sub>outdoor amb.</sub>	[25,30)	[30,38)	[38,40)	[40,45)	[45,49)	[49,53)	> 53
Lower limit frequency	a9	a10	a11	a12	a13	a14	a15
Upper limit frequency	b9	b10	b11	b12	b13	b14	b15

(2) Upper and lower limit frequency of heating mode (Specific parameters are subject to EPPROM)

No.	1	2	3	4	5
T <sub>outdoor amb.</sub>	< -15	[-15,-10)	[-10,-5)	[-5,-1)	[-1,5)
Lower limit frequency	c1	c2	c3	c4	c5
Upper limit frequency	d1	d2	d3	d4	d5

No.	6	7	8	9	10
T <sub>outdoor amb.</sub>	[5,9)	[9,14)	[14,19)	[19,22)	> 22
Lower limit frequency	c6	c7	c8	c9	c10
Upper limit frequency	d6	d7	d8	d9	d10

### NOTE

A variation in outdoor ambient temperature exceeding 2°C is required to enable the reset of upper and lower frequency limits.

- **Compressor frequency limit**

**(Parameters to be confirmed by experiments, related to system and compressor drive)**

The frequency reduction speed below the low frequency point of compressor frequency F is A low frequency reduction speed;

If the compressor phase current  $\geq I_{min1}$ , the minimum operating frequency of the compressor is F lower limit frequency 1;

If the compressor phase current  $\geq I_{min2}$ , the minimum operating frequency of the compressor is F lower limit frequency 2;

If the phase current of the compressor is  $\geq I_{min3}$ , the minimum operating frequency of the compressor is F lower limit frequency 3.

- **Up/down frequency speed of compressor**

**(Parameters to be confirmed by experiment, related to system and compressor drive)**

When the compressor is in normal operation, the rising and falling frequency speed is A. *Normal rising and falling frequency speed=1Hz/s;*

All kinds of protection frequency reduction shall be controlled according to the frequency reduction speed required by the control function. If there is no speed requirement, the frequency shall be reduced according to *A normal protection frequency reduction speed=2Hz/s;* The frequency value of each frequency reduction is  $\Delta F=cX\Sigma P/P$  (when the *exhaust is*  $\geq 110^{\circ}\text{C}$ ,  $c=20$ , the rest  $c=13$ ); When the internal machine causes frequency reduction (such as heating and high temperature prevention),  $\Sigma P$  is the sum of the rated capacity of all internal machines in the down-frequency state; when the whole machine

causes the down-frequency state (such as outdoor pipe temperature, exhaust temperature, current down-frequency, DC bus current down-frequency, etc.),  $\Sigma P$  is the sum of the rated capacity of all internal machines in operation.

If the capacity demand is reduced due to the change of the set temperature and ambient temperature and the capacity demand is reduced due to the external ambient temperature, the frequency shall be adjusted slowly according to the frequency reduction speed of temperature  $A=1\text{Hz}/3\text{s}$ , When the frequency of the compressor is recovered from various frequency limits, the frequency shall be adjusted according to the low frequency *frequency reduction speed* $=1\text{Hz}/25\text{s}$ . After reaching the target frequency, exit the slow rise.

#### NOTE

Other slow rise exit conditions take precedence over this condition.

During heating overload limit and frequency reduction, some internal machines exit. During normal operation, the frequency rise and fall speed is *A normal frequency rise and fall speed* $=1\text{Hz}/\text{s}$ ; After all internal machines exit, they will be adjusted according to *A low frequency frequency reduction speed* $=1\text{Hz}/25\text{s}$ . After reaching the target frequency, exit the slow rise.

#### NOTE

Other slow rise exit conditions take precedence over this condition.

- **Compressor frequency rise stay**

**(Parameters to be confirmed by the experiment, and the system and compressor drive related)**

When the frequency rises to F dwell frequency 1, stay for Tf1 minutes.

When it rises to F dwell frequency 4, stay for Tf2 minutes.

When it rises to F dwell frequency 7, stay for Tf3 minutes.

When it rises to F dwell frequency 2, F dwell frequency 3, F dwell frequency 5, F dwell frequency 6, F dwell frequency 8 and F dwell frequency 9, stay for Tf4 seconds.

When the compressor starts to reach the F dwell frequency 1, it needs to stabilize Tf1 minutes before allowing the frequency to increase or decrease according to the capacity demand.

### 3.2 Power limiting operation

The function is for limiting power of the whole unit. Press "Mode" and "Sleep" buttons simultaneously. The power is reduced to below 75% in low watt mode 1 and below 50% in low watt mode 2.

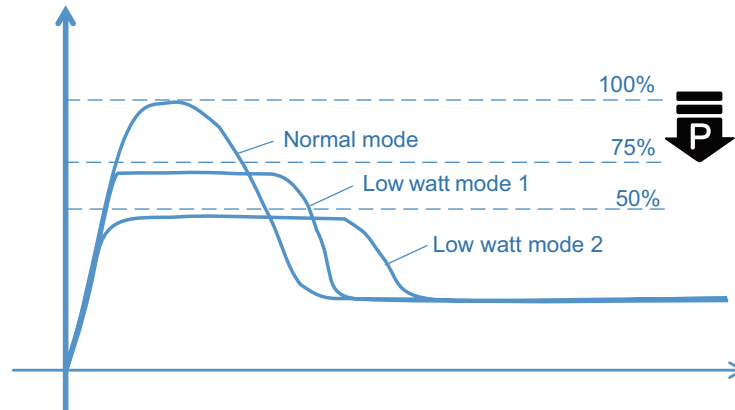

### 3.3 Mode Changing

- **4-way valve control**

The four way valve coil is energized/not energized depending on the operation (Heating: ON, Cooling/Dry/Defrost: OFF). In order to eliminate the switching sound as the four way valve coil switches from ON to OFF when the heating is stopped, the OFF delay switch of the four way valve is carried out.

- **3-Minute Standby**

Turning on the compressor is prohibited for 3 minutes after turning it off. (The function is not activated when defrosting.)

- **Compressor protection function-stop point and stop time during frequency-increasing process**

When turning the compressor from OFF to ON, there is stop point of frequency during the frequency-increasing process. It will stop for some at certain frequency. This stop time is determined by the system. (The function is not activated when defrosting.)

### 3.4 Discharge Pipe Temperature Control

The discharge pipe temperature is used as the internal temperature of the compressor. If the discharge pipe temperature rises above a certain level, the upper limit of frequency is set to keep the discharge pipe temperature from rising further.

Detail:

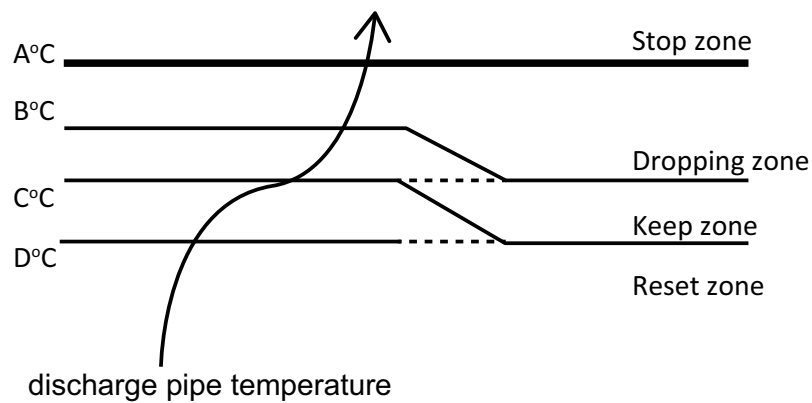

Zone	Temperature
A (°C)	115
B (°C)	107
C (°C)	105
D (°C)	100

Zone	Control
Stop zone	When the temperature reaches the stop zone, the compressor stops.
Dropping zone	The upper limit of frequency decreases.
Keep zone	The upper limit of frequency is kept.
Reset zone	The upper limit of frequency is canceled.

NOTE: There are slight differences between different models.

### 3.5 Input Current Control

The microcomputer calculates the input current while the compressor is running, and sets the frequency upper limit based on the input current.

### 3.6 Evaporator frozen-preventing protection function

Whether decreasing frequency or not is determined by the temperature detected by the evaporator temperature sensor. If there is still frost after decreasing, the outdoor fan stops operation.

### 3.7 High Temperature Protection

Under cooling mode, the system is prevented from reaching abnormal high pressure by controlling the heat exchanger pipe temperature of the outdoor unit. Under heating mode, the system is prevented from reaching abnormal high pressure by controlling the heat exchanger pipe temperature of the indoor unit.

- **Control measures**

Judge according to the temperature detected by the temperature sensor on the heat exchanger, and then control the frequency of the compressor.

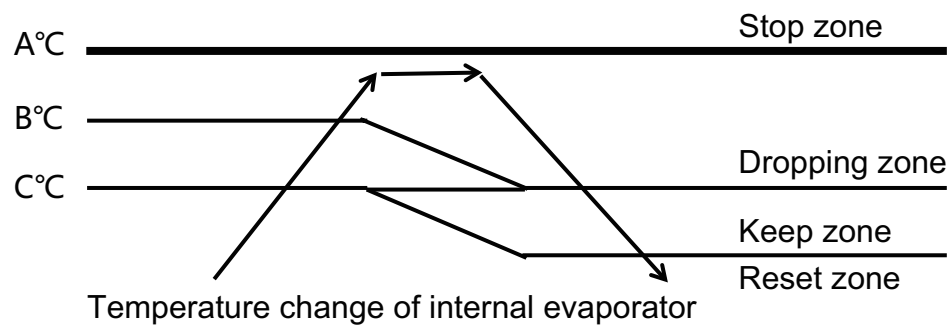

Outdoor unit temperature under cooling mode:

Model	A (°C)	B (°C)	C (°C)
09K	62	58	52
12K	66	62	59
18K Cooling	64	61	58
18K Heat pump	65	61	57
24K or above	68	64	62

Indoor unit's pipe temperature under heating mode:

Model	A (°C)	B (°C)	C (°C)
09K	62	56	50
12K	62	56	50
18K	62	57	52
24K or above	62	57	52

Zone	Control
Stop zone	When the temperature reaches the stop zone, the compressor stops.
Dropping zone	The upper limit of frequency decreases.
Keep zone	The upper limit of frequency is kept.
Reset zone	The upper limit of frequency is canceled.

### 3.8 Outdoor fan control

#### 1. Fan OFF control during defrosting

The outdoor fan is turned OFF during defrosting.

#### 2. Fan OFF delay when stopped

The outdoor fan is turned OFF 60 seconds after the compressor stops.

#### 3. The fan is started up before the compressor

The outdoor fan is turned on 20 seconds before the compressor starts.

#### 4. Outdoor fan speed control under low-temperature cooling mode

If the unit is with low-temperature cooling function, the speed of the outdoor fan is controlled to ensure that the evaporator is not defrosting during cooling operation with low outdoor temperature.

1. When the pipe temperature of outdoor unit is low, the rotation speed of the outdoor fan is reduced.
2. When the pipe temperature of outdoor unit is high, the rotation speed of the outdoor fan is controlled as well as normal operation.

#### 5. Fan speed control during indoor/outdoor unit quiet operation

The rotation speed of the outdoor fan is reduced by the command of the indoor/outdoor unit quiet operation.

#### 6. Fan ON/OFF control when operation (cooling, heating, dry) starts/stops

The outdoor fan is turned ON when the operation starts. The outdoor fan is turned OFF when the operation stops.

### 3.9 Cold Air Prevention Control

- **Outline**

Under heating mode, in order to improve the user's comfort experience, prevent cold air blowing to the user when the evaporator temperature is not high.

- **Detail**

Under heating mode, the position of the horizontal louver and the speed of the indoor unit are automatically adjusted according to the temperature of the indoor heat exchanger pipe:

1. When the compressor starts or enters defrosting, the horizontal louver is adjusted to the first position. After the indoor heat exchanger pipe temperature rises, the horizontal louver is adjusted to the default position in heating or the set position.
2. When the indoor ambient temperature and indoor heat exchanger pipe temperature are very low, the indoor fan does not operate, and the maximum time of non-operation is not more than 2 minutes. When the pipe temperature rises or the limit time of 2 minutes is reached, the indoor fan runs at a low speed, and the maximum time of low speed operation does not exceed 1 minute.

When the pipe temperature continues to rise or the limit time of 1 minute is reached, the indoor fan runs at the set speed.

3. When the indoor ambient temperature is high, but the indoor heat exchanger pipe temperature is low, the indoor fan runs at a low speed, and the maximum time of low speed operation is not more than 1 minute. When the pipe temperature rises or the limit time of 1 minute is reached, the indoor fan runs at the set speed.

### 3.10 Defrost Control

- **Outline**

Defrosting is carried out by the cooling cycle (reverse cycle). The defrosting time or outdoor heat exchanger temperature must be more than a certain value to finish defrosting.

- **Detail**

- **Conditions for Starting Defrost**

1. The starting conditions are determined with the outdoor temperature and the outdoor heat exchanger temperature.
2. The system is in heating operation.
3. The compressor operates for 10 minutes.
4. More than A minutes (depending on the duration of the previous defrost control) of accumulated time have passed since the start of the operation, or ending the previous defrosting.

- **Conditions for Canceling Defrost**

The judgment is made with the outdoor heat exchanger temperature. (B°C)

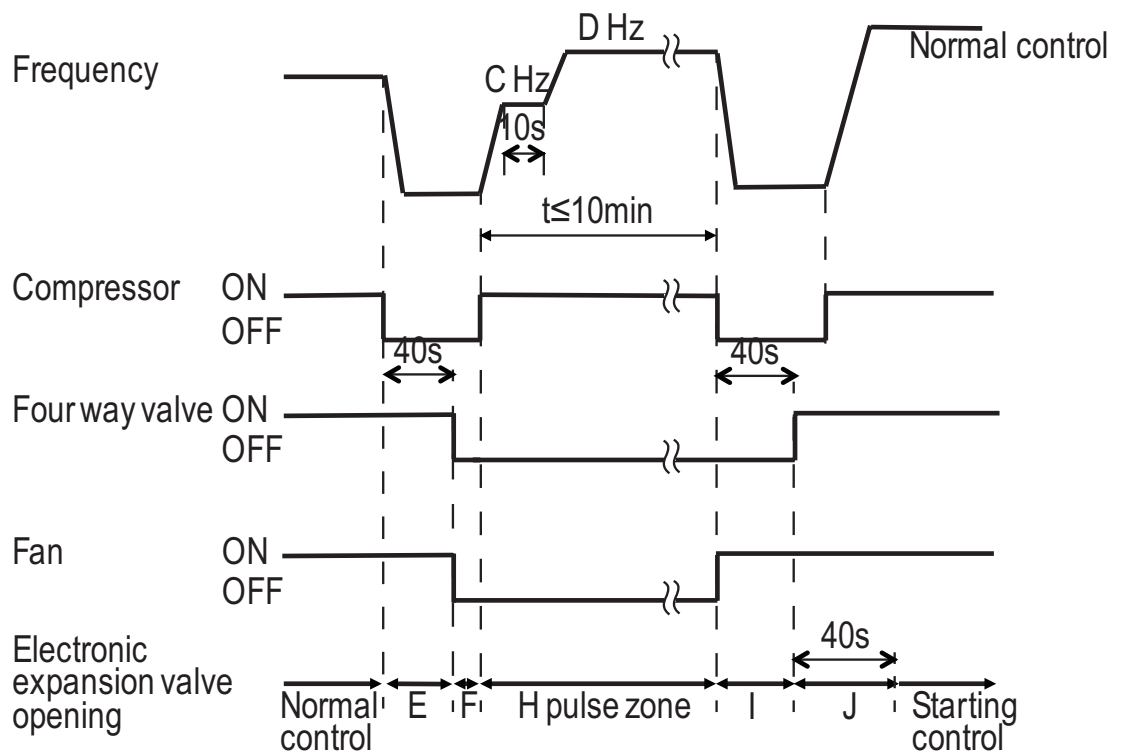

<b>Model</b>	<b>A</b> (minutes)	<b>B</b> (°C)	<b>C</b> (Hz)	<b>D</b> (Hz)	<b>E</b> (pulse)	<b>F</b> (pulse)	<b>H</b> (pulse)	<b>I</b> (pulse)	<b>J</b> (pulse)
07K, 09K	45	6~12	60	90	480	150	250	480	250★
12K	45	13~18	60	90	480	150	280	480	250★
18K	45	6~12	60	90	480	250	300	480	300★
24K	45	6~12	60	90	480	150	250	480	310★
30K, 36K	45	6~12	60	90	480	150	250	480	320★

★: Above data are different for different models.

### 3.11 Electronic Expansion Valve Control

- **Outline**

The following items are included in the electronic expansion valve control.

- **Electronic expansion valve is fully opened**

1. Electronic expansion valve is fully opened when turning off the power.
2. Pressure equalizing control.

- **Change Control**

1. Electronic expansion valve control when starting operation.
2. Electronic expansion valve control when the frequency changes.
3. Electronic expansion valve control for defrosting
4. Electronic expansion valve control when the discharge pipe temperature is abnormally high.
5. Electronic expansion valve control when the air conditioner limits or decreases frequency.

- **Feedback Control**

Target discharge pipe temperature control

1. Changing with Power ON

The electronic expansion valve is initialized when turning on the power. The opening position is set and the pressure is equalized.

2. Pressure Equalizing Control

When the compressor is stopped, the pressure equalizing control is activated. The electronic expansion valve opens and the pressure is equalized.

3. Opening Limit Control

The maximum and minimum opening of the electronic expansion valve are limited.

Opening Situation	Pulse
Maximum opening	480
Minimum opening	50

The electronic expansion valve is fully opened when cooling operation stops, and is controlled at a fixed degree during defrosting.

#### 4. Starting Operation Control

The electronic expansion valve keeps initialized pulse 40s when the operation starts, thus preventing superheating or liquid compression.

#### 5. Control when the Frequency Changes

When the target discharge pipe temperature control is active, if the target frequency changes to a specified value in a certain time period, the target discharge pipe temperature control is canceled and the target opening of the electronic expansion valve is changed according to the frequency shift.

#### 6. High Discharge Pipe Temperature Control

When the compressor is operating, if the discharge pipe temperature exceeds a certain value, the electronic expansion valve opens and the refrigerant runs to the low pressure side. This procedure lowers the discharge pipe temperature.

#### 7. Frequency Limiting or Decreasing Control

When the system occurs frequency limiting or reduction for overcurrent, high temperature, overload and other reason, the opening degree of the electronic expansion valve is only allowed to increase but not allowed to decrease.

#### 8. Target Discharge Pipe Temperature Control

The target discharge pipe temperature is obtained from the indoor and outdoor environment temperature, and the electronic expansion valve opening is adjusted so that the actual discharge pipe temperature becomes close to the target discharge pipe temperature.

The electronic expansion valve opening and the target discharge pipe temperature are checked every 40 seconds.

### 3.12 Mainboard Module Overheating Protection

- Outline**

During operation, you can control the temperature of the mainboard module to prevent the mainboard from being damaged due to excessive temperature.

- Detail**

According to the temperature and voltage output of the module on the mainboard, the temperature value is determined, and then the frequency of the compressor is controlled.

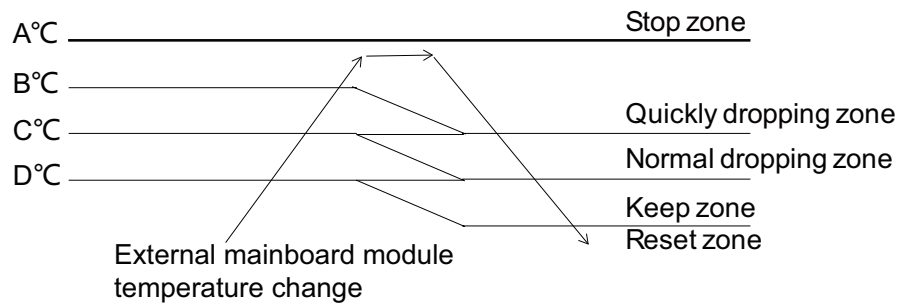

Mainboard module overheating protection temperature:

Model	A (°C)	B (°C)	C (°C)	D (°C)
09K	100	96	93	90
12K	100	95	93	90
18K Cooling	100	96	93	90
18K Heat pump	95	93	90	87
24K and above	98	95	93	90

Zone	Control
Stop zone	When the temperature reaches the stop zone, the compressor stops.
Quickly dropping zone	The upper limit of frequency quickly decreases until it drops to 44Hz or the lower limit.
Dropping zone	The upper limit of frequency decreases until it drops to 44Hz or the lower limit.
Keep zone	The upper limit of frequency is kept.
Reset zone	The upper limit of frequency is canceled.

**NOTICE**

If the unit stops for six consecutive times due to overheating protection of mainboard module, it cannot automatically resume operation, and ON/OFF shall be pressed to resume operation.

### **3.13 Refrigerant Lacking Protection**

- **Outline**

In the initial stage of operation under cooling or dry mode, it will be judged according to the change of outdoor heat exchanger pipe temperature, the change of indoor heat exchanger pipe temperature and the difference between indoor heat exchanger pipe temperature and indoor ambient temperature, and the start and stop of the compressor is controlled to prevent the compressor from being damaged due to excessive temperature rise of the compressor motor.

- **Detail**

Under cooling or dry mode, when the compressor is operating, if the following conditions are met at the same time:

Outdoor heat exchanger pipe temperature change  $\leq 2^{\circ}\text{C}$

Indoor heat exchanger pipe temperature change  $\leq 2^{\circ}\text{C}$

The difference between the indoor heat exchanger pipe temperature and the indoor ambient temperature  $\leq 2^{\circ}\text{C}$

Compressor operating frequency  $\geq 30\text{Hz}$

It is determined that the system lacks refrigerant, and the complete unit is shut down for protection. If the unit stops for 3 consecutive times due to protection, the operation cannot be automatically resumed, and the indoor unit displays refrigerant lacking and valve blockage error code F0, which needs to be restored by reenergization.

## 3.14 Malfunctions

### 1. Sensor Malfunction Detection

Sensor malfunction can be detected in the following thermistors:

1. Outdoor heat exchanger thermistor
2. Discharge pipe thermistor
3. Outdoor temperature thermistor

When the temperature sensor error is detected, the complete unit will stop for protection.

### 2. Detection of Overcurrent and Overload

- **Outline**

An excessive output current is detected and the overload temperature is observed to protect the compressor.

- **Detail**

1. If the overload (compressor head) temperature exceeds 115°C, the system shuts down the compressor.
2. If the inverter current exceeds 10~22A (depending on the model), the system shuts down the compressor.

# 7.3 GREE+ App Operation Manual

## Control Flow Chart

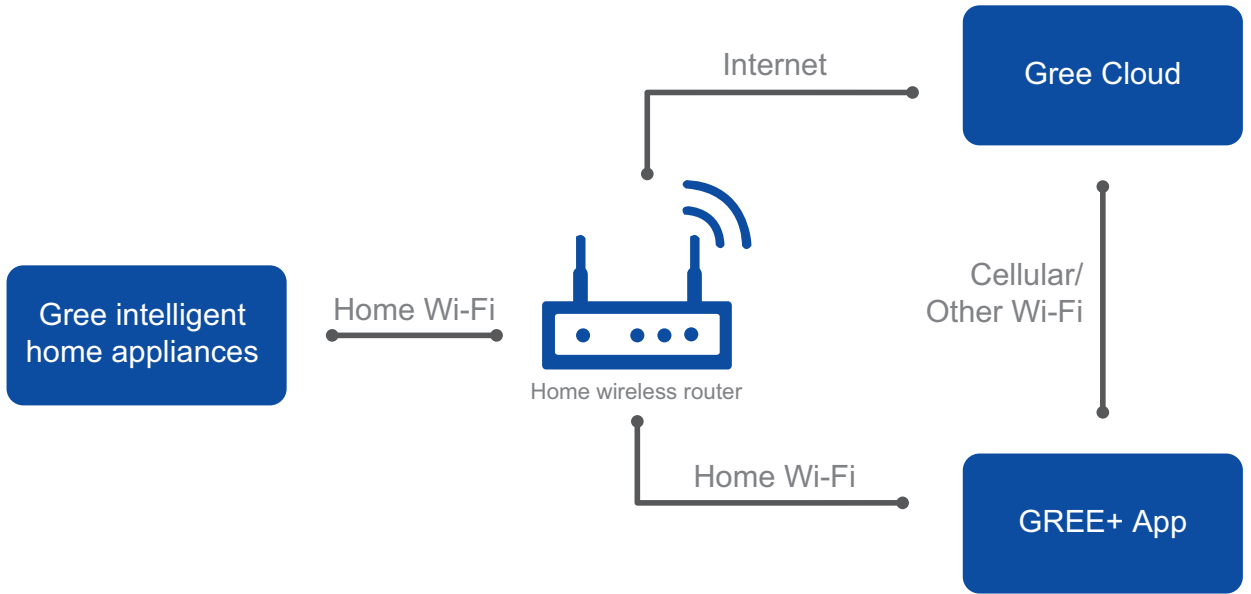

## Operating Systems

Requirement for User's smart phone:



**iOS** system  
Support iOS 7.0  
and above version



**Android** system  
Support Android 4.4  
and above version

## Download and installation

Scan the QR code or search "GREE+" in the application market to download and install it. When "GREE+" App is installed, register the account and add the device to achieve long-distance control and LAN control of Gree smart home appliances.

For more information, please refer to "Help" in App.



GREE+ App Download Linkage

## 7.4 Ewpe Smart App Operation Manual

### Control Flow Chart

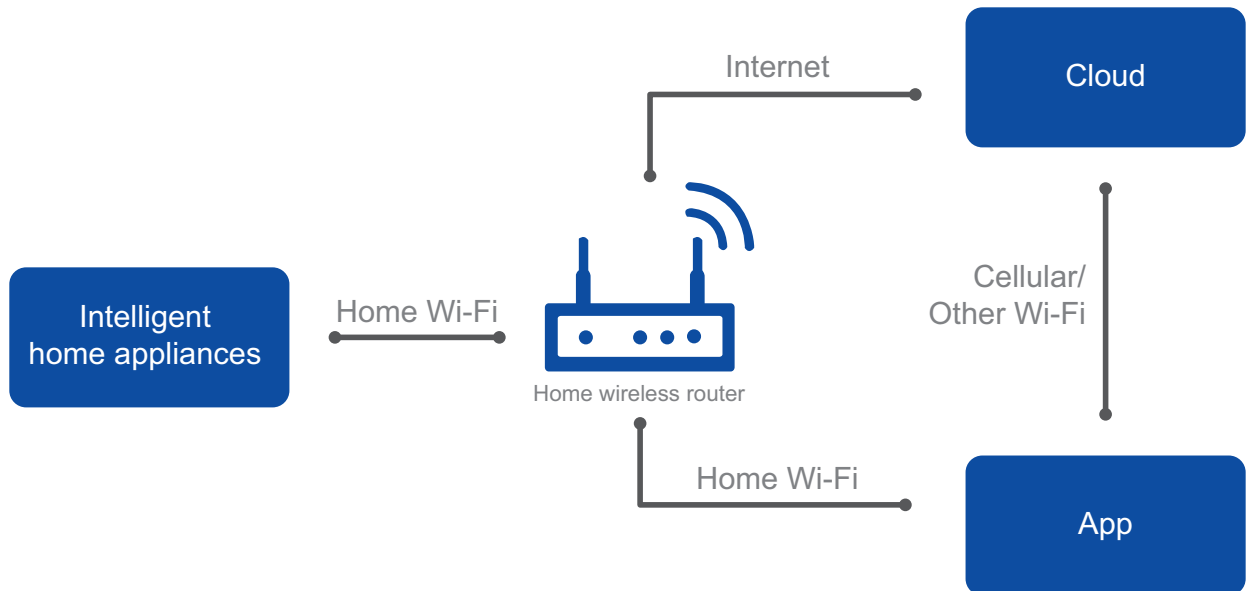

### Operating Systems

Requirement for User's smart phone:



**iOS** system  
Support iOS 7.0  
and above version



**Android** system  
Support Android 4.4  
and above version

### Download and installation

Scan the QR code or search "Ewpe Smart" in the application market to download and install it. When "Ewpe Smart" App is installed, register the account and add the device to achieve long-distance control and LAN control of smart home appliances.

For more information, please refer to "Help" in App.



App Download Linkage

# 8. Installation

## 8.1 Installation Dimension Diagram

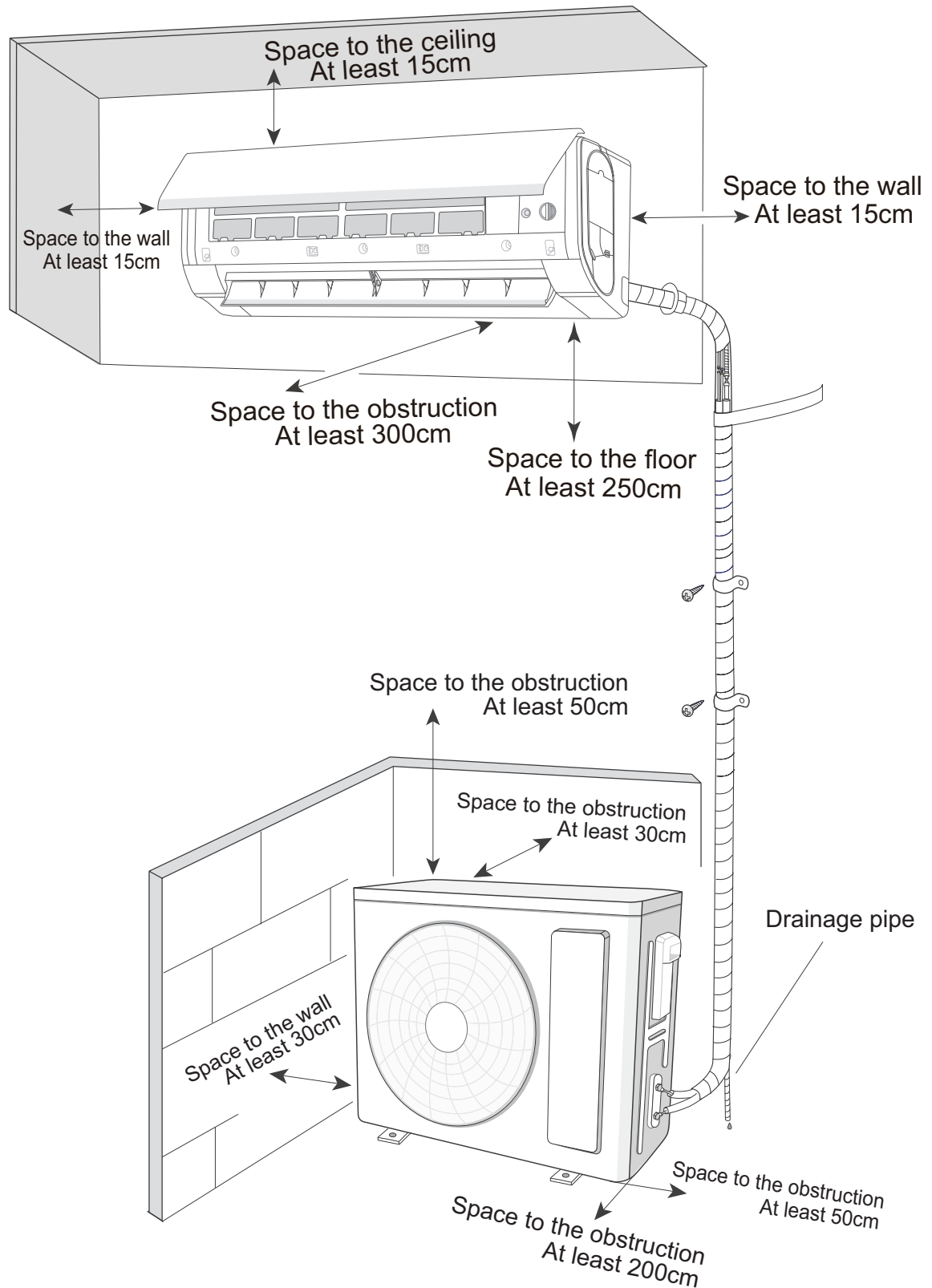

# Installation Procedures

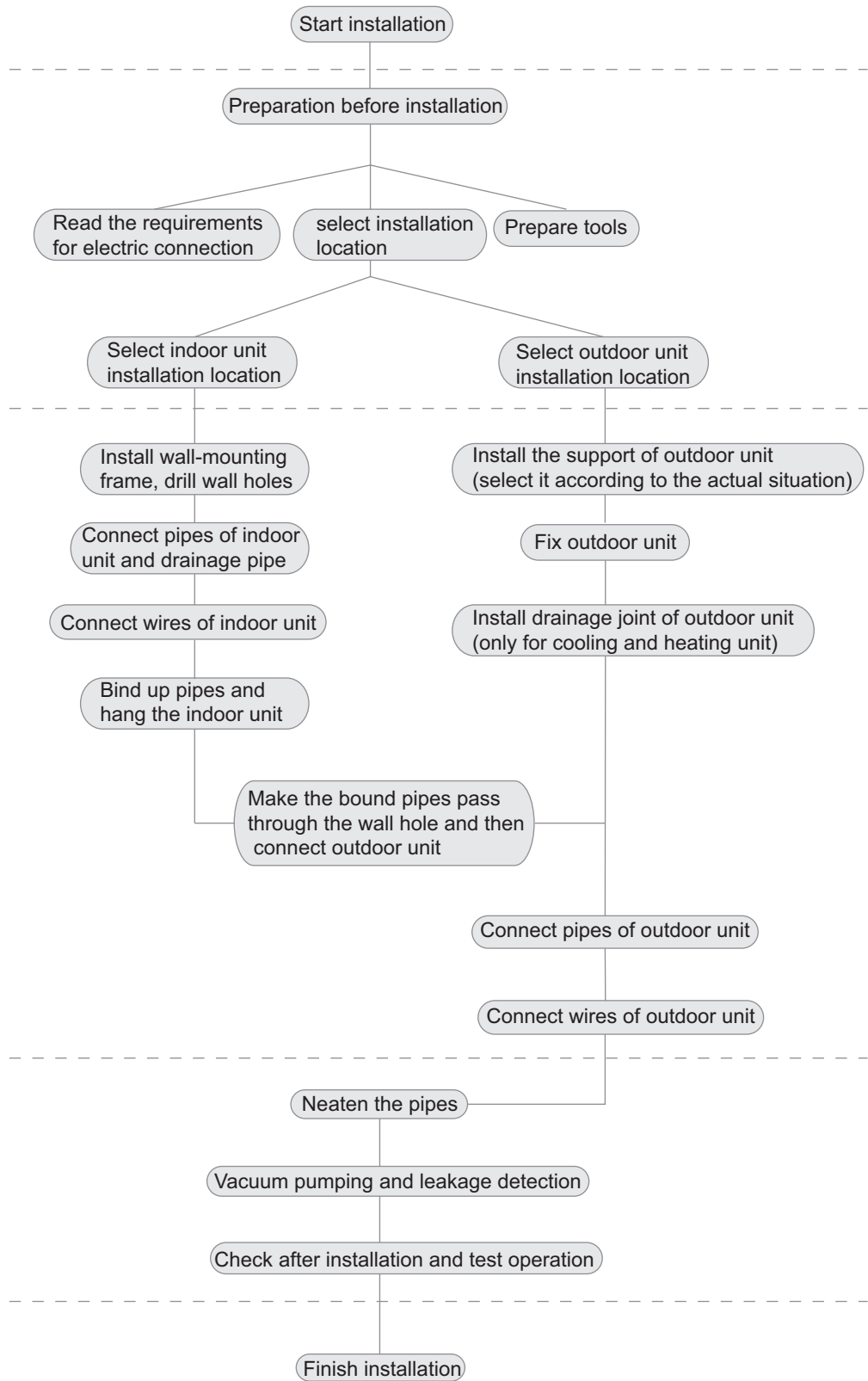

Note: this flow is only for reference; please find the more detailed installation steps in this section.

## Main tools for installation and maintenance



**Level meter**



**Measuring tape**



**Screw driver**



**Impact drill**



**Drill head**



**Electric drill**



**Electroprobe**



**Universal meter**



**Torque wrench**



**Open-end wrench**



**Inner hexagon spanner**



**Electronic leakage detector**



**Vacuum pump**



**Pressure meter**



**Pipe pliers**



**Pipe pliers**



**Pipe cutter**



**Pipe expander**



**Pipe bender**



**Soldering appliance**



**Refrigerant container**



**Electronic scale**

## 8.2 Installation Parts-checking

No.	Name	No.	Name
1	Indoor unit	8	Sealing gum
2	Outdoor unit	9	Wrapping tape
3	Connection pipe	10	Support of outdoor unit
4	Drainage pipe	11	Fixing screw
5	Wall-mounting frame	12	Drainage plug (Heat pump model)
6	Connecting cable (Power Cord)	13	Owners manual
7	Wall pipe	14	Remote controller

 **NOTE:**

1. Please contact the local agent for installation.
2. Don't use unqualified power cord.

## 8.3 Selection of Installation Location

### 1. *Basic Requirement*

Installing the unit in the following places may cause malfunction. If it is unavoidable, please consult the local dealer:

- (1) The place with strong heat sources, vapors, flammable or explosive gas, or volatile objects spread in the air.
- (2) The place with high-frequency devices (such as welding machine, medical equipment).
- (3) The place near coast area.
- (4) The place with oil or fumes in the air.
- (5) The place with sulfureted gas.
- (6) Other places with special circumstances.
- (7) The appliance shall not be installed in the laundry.
- (8) It's not allowed to be installed on the unstable or motive base structure (such as truck) or in the corrosive environment (such as chemical factory).

### 2. *Indoor unit*

- (1) There should be no obstruction near air inlet and air outlet.
- (2) Select a location where the condensation water can be dispersed easily and won't affect other people.
- (3) Select a location which is convenient to connect the outdoor unit and near the power socket.
- (4) Select a location which is out of reach for children.
- (5) The location should be able to withstand the weight of indoor unit and won't increase noise and vibration.
- (6) The appliance must be installed 2.5m above floor.
- (7) Don't install the indoor unit right above the electric appliance.
- (8) Please try your best to keep away from fluorescent lamp.

### **3. Outdoor Unit**

- (1) Select a location where the noise and outflow air emitted by the outdoor unit will not affect neighborhood.
- (2) The location should be well ventilated and dry, in which the outdoor unit won't be exposed directly to sunlight or strong wind.
- (3) The location should be able to withstand the weight of outdoor unit.
- (4) Make sure that the installation follows the requirement of installation dimension diagram.
- (5) Select a location which is out of reach for children and far away from animals or plants. If it is unavoidable, please add fence for safety purpose.

## 8.4 Electric Connection Requirement

### 1. Safety Precaution

- (1) Must follow the electric safety regulations when installing the unit.
- (2) According to the local safety regulations, use qualified power supply circuit and air switch.
- (3) Make sure the power supply matches with the requirement of air conditioner. Unstable power supply or incorrect wiring may result in electric shock, fire hazard or malfunction. Please install proper power supply cables before using the air conditioner.
- (4) Properly connect the live wire, neutral wire and grounding wire of power socket.
- (5) Be sure to cut off the power supply before proceeding any work related to electricity and safety.
- (6) Do not put through the power before finishing installation.
- (7) The temperature of refrigerant circuit will be high, please keep the interconnection cable away from the copper tube.
- (8) The appliance shall be installed in accordance with national wiring regulations.

### 2. Grounding Requirement

- (1) The air conditioner is I class electric appliance. It must be properly grounding with specialized grounding device by a professional. Please make sure it is always grounded effectively, otherwise it may cause electric shock.
- (2) The yellow-green wire in air conditioner is grounding wire, which can't be used for other purposes.
- (3) The grounding resistance should comply with national electric safety regulations.
- (4) The appliance must be positioned so that the plug is accessible.
- (5) An all-pole disconnection switch having a contact separation of at least 3mm in all poles should be connected in fixed wiring.
- (6) Including an air switch with suitable capacity, please note the following table.

Air switch should be included magnet buckle and heating buckle function, it can protect the circuit-short and overload. (Caution: please do not use the fuse only for protect the circuit)

<b>Model</b>	<b>Air switch capacity</b>	<b>Power cord</b>
09/12K	10A	3G1.0
18/24K	16A	3G1.5

## 8.5 Installation of Indoor Unit

### 1. Choosing Installation Location

Recommend the installation location to the client and then confirm it with the client.

### 2. Install wall-mounting frame

- (1) Hang the wall-mounting frame on the wall; adjust it to a horizontal position using a level meter, and then mark the screw fixing holes on the wall.
- (2) Drill the screw fixing holes on the wall using an impact drill (the drill bit size should match the plastic expansion anchor), and then insert the plastic expansion anchors into the holes.
- (3) Secure the wall-mounting frame to the wall using tapping screws, and then check if the frame is firmly installed by pulling on it. If the plastic expansion anchor is loose, drill another fixing hole nearby.

### 3. Drill Piping Hole

- (1) Choose the position of the piping hole according to the direction of the outlet pipe. The position of the piping hole should be slightly lower than the wall-mounted frame. (As shown in Fig. 1)

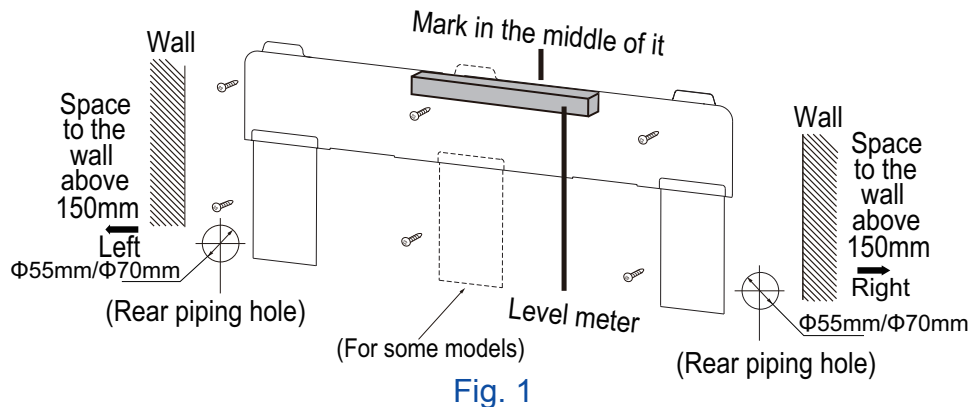

- (2) When installation is finished, pull the mounting plate by hand to confirm whether it is fixed tightly. The force distribution among all screws should be uniform.

- (3) Drill a piping hole with a diameter of  $\Phi 55\text{mm}$  or  $\Phi 70\text{mm}$  at the selected outlet pipe position. To ensure smooth drainage, slant the piping hole on the wall slightly downward toward the outdoor side with a gradient of  $5-10^\circ$ . (As shown in Fig. 2)

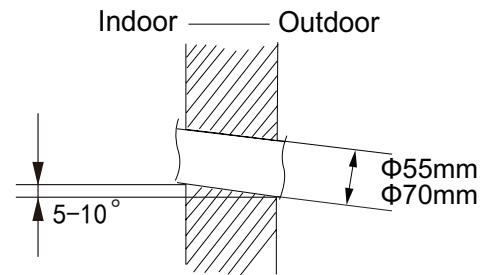

Fig. 2

**NOTE:**

Pay attention to dust prevention and take relevant safety measures when drilling the hole.

#### 4. Outlet Pipe

- (1) The pipe can be led out in the direction of right, rear right, left, or rear left. (As shown in Fig. 3)

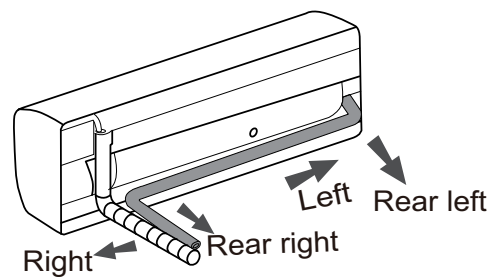

Fig. 3

- (2) When selecting to lead out the pipe from the left or right, please cut the corresponding hole in the bottom case. (As shown in Fig. 4)

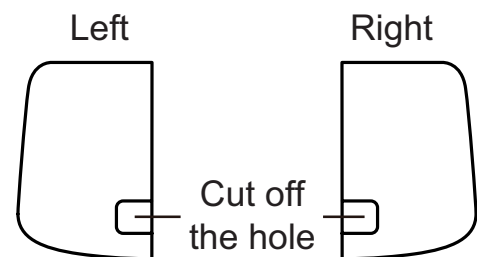

Fig. 4

## 5. Connect the Pipe of Indoor Unit

- (1) Aim the pipe joint at the corresponding bellmouth.  
(As shown in Fig. 5)

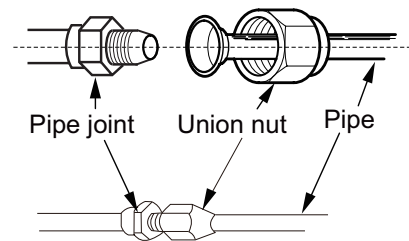

Fig. 5

- (2) Pretighten the union nut by hand.
- (3) Adjust the torque force by referring to the following sheet. Place the open-end wrench on the pipe joint and the torque wrench on the union nut. Tighten the union nut with the torque wrench. (As shown in Fig. 6)

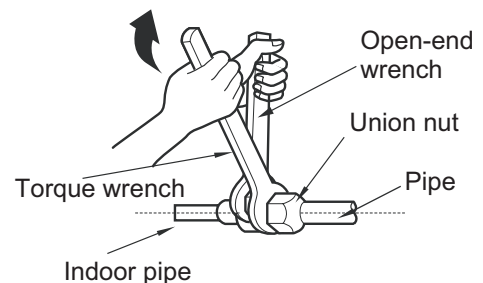

Fig. 6

- (4) Wrap the indoor pipe and the joint of the connection pipe with insulating pipe, and then wrap it with tape.  
(As shown in Fig. 7)

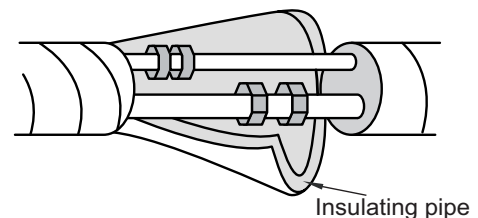

Fig. 7

Refer to the following table for wrench moment of force:

Piping size (inch)	Tightening torque (N·m)
1/4	15~20
3/8	30~40
1/2	45~55
5/8	60~65
3/4	70~75

## 6. Install Drain Hose

- (1) Connect the drain hose to the outlet pipe of the indoor unit.  
(As shown in Fig. 8)

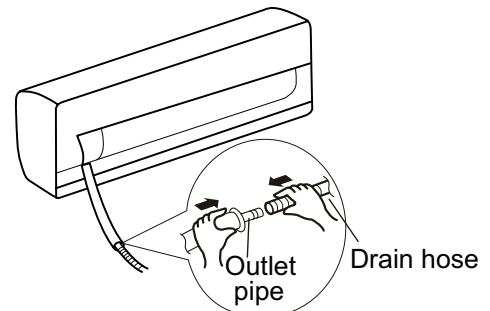

Fig. 8

- (2) Bind the joint with tape.  
(As shown in Fig. 9)

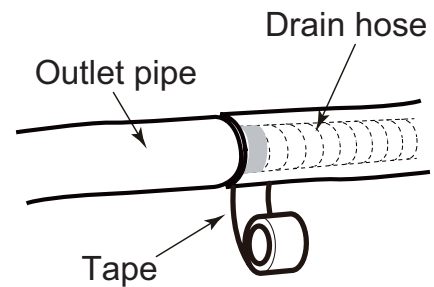

Fig. 9

- (3) Add insulating pipe to the indoor drain hose to prevent condensation.  
(As shown in Fig. 10)

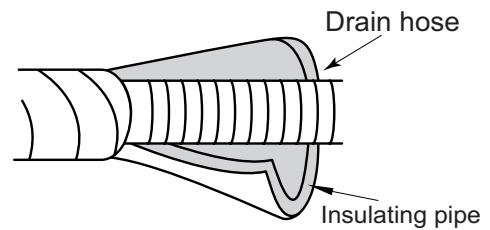

Fig.10

### NOTE:

- The plastic expansion bolts are not provided.

## 7. Connect Wire of Indoor Unit

### NOTICE:

- All wires of the indoor unit and the outdoor unit should be connected by a professional.
- If the length of the power connection wire is insufficient, please contact the supplier for a new one. Avoid extending the wire yourself.
- For the air conditioner with a plug, the plug should be reachable after installation.
- For the air conditioner without a plug, an air switch must be installed in the line. The air switch should be all-pole parting, and the contact parting distance should be more than 3mm.

- (1) Open the panel, remove the screw on the wiring cover, and then take down the cover.  
(As shown in Fig. 11)

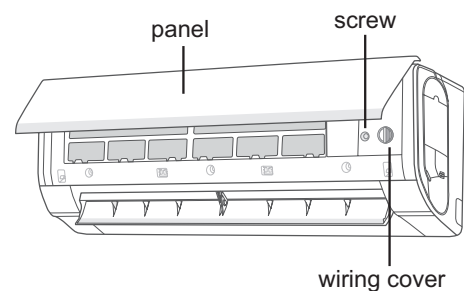

Fig. 11

- (2) Make the power connection wire go through the cable-cross hole at the back of the indoor unit and then pull it out from the front side.  
(As shown in Fig. 12)

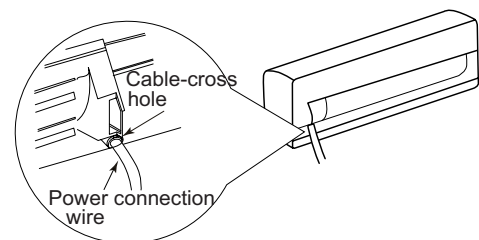

Fig. 12

- (3) Remove the wire clip; connect the power connection wire and the signal control wire (only for cooling and heating units) to the wiring terminal according to the color; tighten the screw, and then fix the power connection wire with the wire clip. (As shown in Fig. 13)

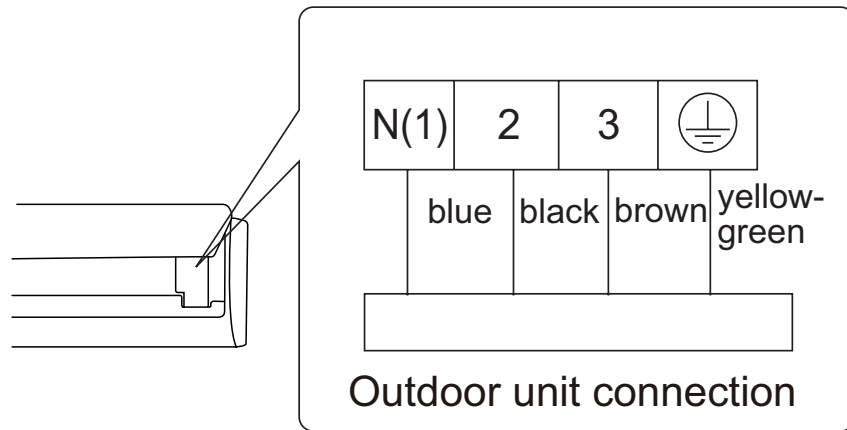

Fig. 13

- (4) Put the wiring cover back and then tighten the screw.
- (5) Close the panel.

**NOTICE:**

The wiring board is for reference only. Please refer to the actual one.

## 8. Bind up Pipe

- (1) Bind up the connection pipe, power cord, and drain hose with the band. (As shown in Fig. 14)

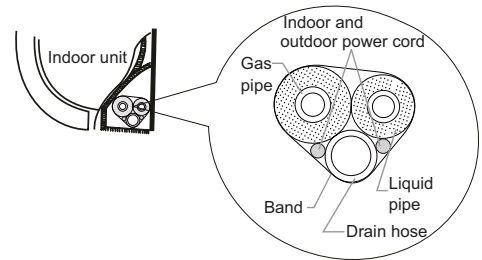

Fig. 14

- (2) Reserve a certain length of drain hose and power cord for installation when binding them. When binding to a certain degree, separate the indoor power and then separate the drain hose. (As shown in Fig. 15)

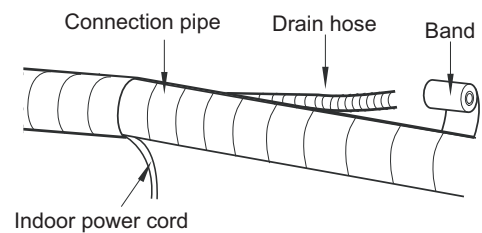

Fig. 15

- (3) Bind them evenly.
- (4) The liquid pipe and gas pipe should be bound separately at the end.

### NOTE:

- The power cord and control wire cannot be crossed or wound.
- The drain hose should be bound at the bottom.

## 9. Hang the Indoor Unit

- (1) Put the bound pipes in the wall pipe and then pass them through the wall hole.
- (2) Hang the indoor unit on the wall-mounting frame.
- (3) Stuff the gap between the pipes and the wall hole with sealing gum.

- (4) Fix the wall pipe.  
(As shown in Fig. 16)

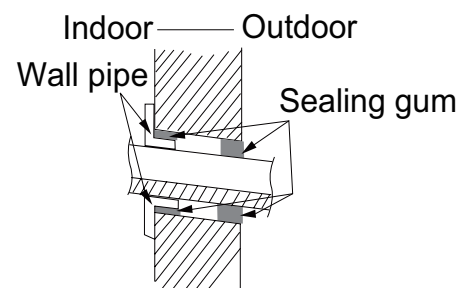

Fig. 16

- (5) Check if the indoor unit is installed firmly and close to the wall. (As shown in Fig. 17)

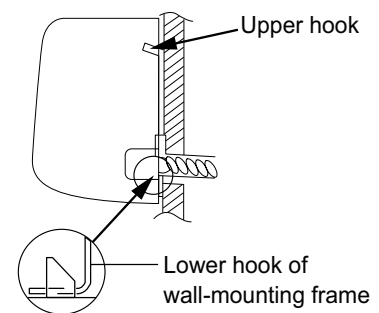

Fig. 17

### NOTE:

Do not bend the drain hose excessively to prevent blocking.

## 8.6 Installation of Outdoor Unit

### 1. Fix the Support of Outdoor Unit (Select it according to the actual installation situation)

- (1) Select installation location according to the house structure.
- (2) Fix the support of outdoor unit on the selected location with expansion screws.

#### NOTICE:

- Take sufficient protective measures when installing the outdoor unit.
- Make sure the support can withstand at least four times the unit weight.
- The outdoor unit should be installed at least 3cm above the floor in order to install drain joint.(As shown in Fig.18)
- For the unit with cooling capacity of 2300W~5000W, 6 expansion screws are needed; for the unit with cooling capacity of 6000W~8000W, 8 expansion screws are needed; for the unit with cooling capacity of 10000W~16000W, 10 expansion screws are needed.

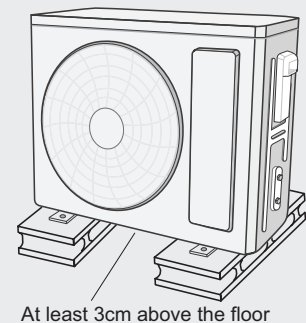

Fig.18

### 2. Install Drain Joint (Only for heat pump models)

- (1) Connect the outdoor drain joint into the hole on the chassis.

- (2) Connect the drain hose into the drain vent. (As shown in Fig.19)

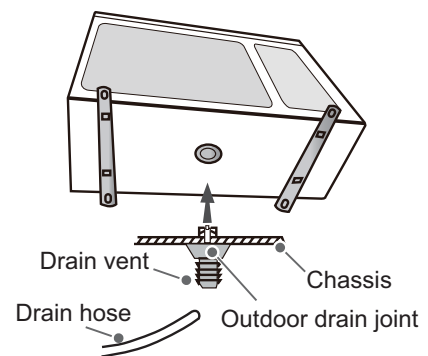

Fig.19

**NOTICE:**

As for the shape of drainage joint, please refer to the current product. Do not install the drainage joint in the severe cold area. Otherwise, it will be frosted and then cause malfunction.

### 3. Fix Outdoor Unit

- (1) Place the outdoor unit on the support.

- (2) Fix the foot holes of outdoor unit with bolts. (As shown in Fig.20)

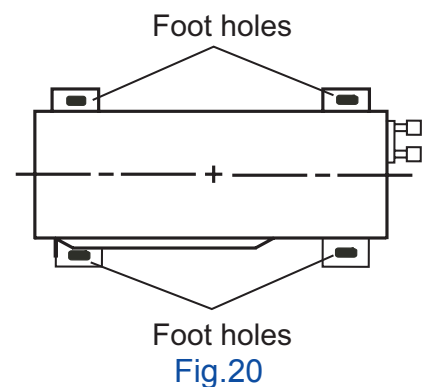
**NOTE:**

When there're multiple cables passing through it, the cross-hole of handle should be knocked off and eliminate the sharp burrs for avoid damaging the cables. Only applicable for some models.

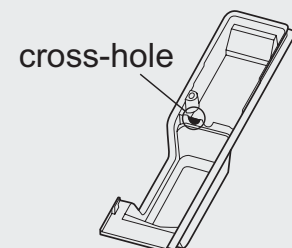

### 4. Connect Indoor and Outdoor Pipes

- (1) Remove the screw on the right handle of outdoor unit and then remove the handle. (As shown in Fig.21)

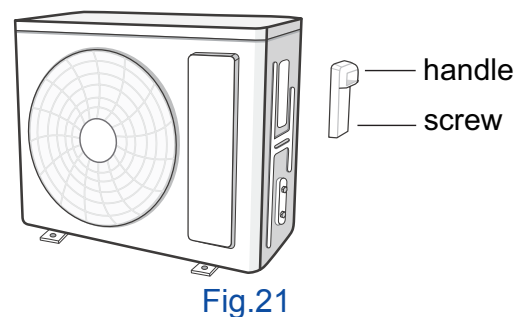

- (2) Remove the screw cap of valve and aim the pipe joint at the bellmouth of pipe. (As shown in Fig.22)

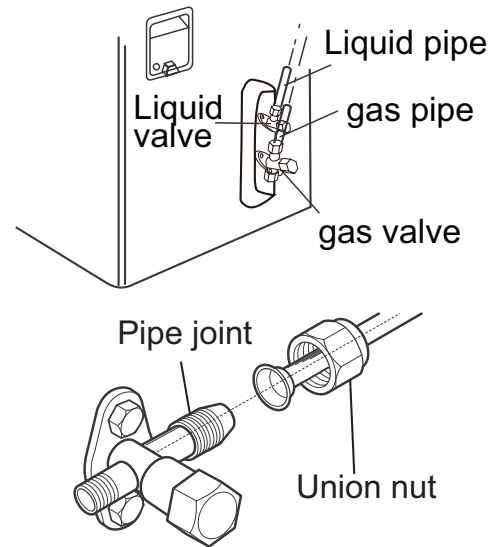

Fig.22

- (3) Pretightening the union nut with hand.
- (4) Tighten the union nut with torque wrench.

Refer to the following table for wrench moment of force:

Piping size (inch)	Tightening torque (N·m)
1/4	15~20
3/8	30~40
1/2	45~55
5/8	60~65
3/4	70~75

## 5. Connect Outdoor Electric Wire

- (1) Remove the wire clip; connect the power connection wire and signal control wire (only for cooling and heating unit) to the wiring terminal according to the color; fix them with screws. (As shown in Fig.23)

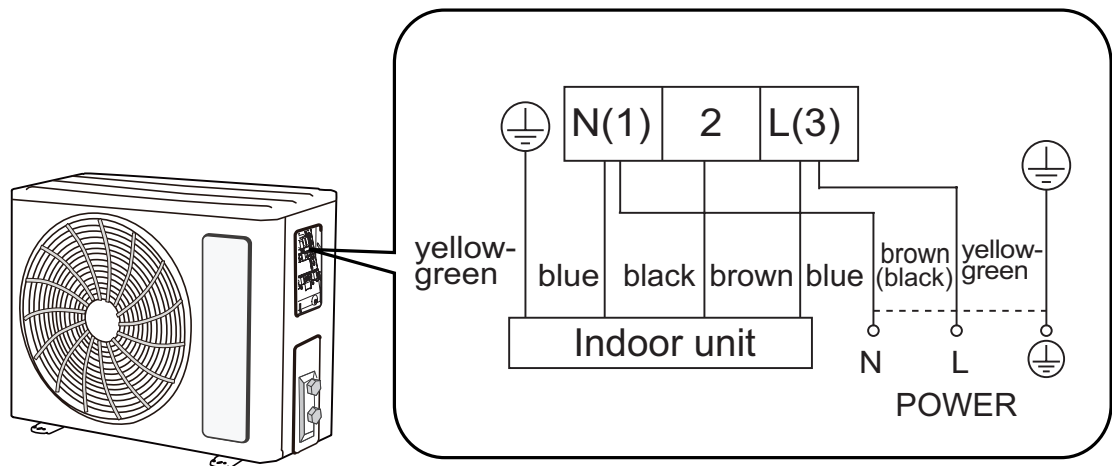

Fig.23

### NOTICE:

The wiring board is for reference only, please refer to the actual one.

- (2) Fix the power connection wire and signal control wire with wire clip (only for heat pump models).

### NOTICE:

- After tightening the screw, pull the power cord slightly to check if it is firm.
- Never cut the power connection wire to prolong or shorten the distance.

## 6. Neaten the Pipes

- (1) The pipes should be placed along the wall, bent reasonably and hidden possibly. Min. semidiameter of bending the pipe is 10cm.

- (2) If the outdoor unit is higher than the wall hole, you must set a U-shaped curve in the pipe before pipe goes into the room, in order to prevent rain from getting into the room. (As shown in Fig.24)

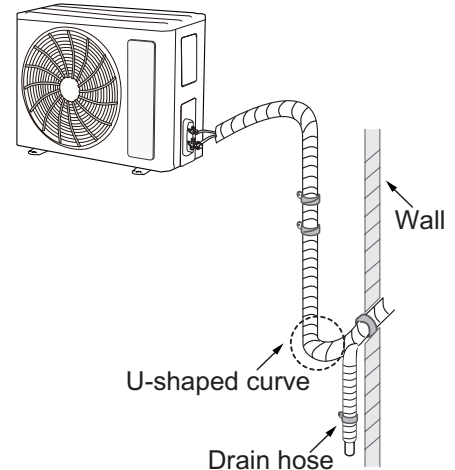

Fig.24

### NOTICE:

- The through-wall height of drain hose shouldn't be higher than the outlet pipe hole of indoor unit. (As shown in Fig.25)

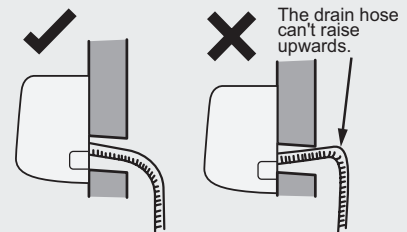

Fig.25

- Slant the drain hose slightly downwards. The drain hose can't be curved, raised and fluctuant, etc. (As shown in Fig.26)

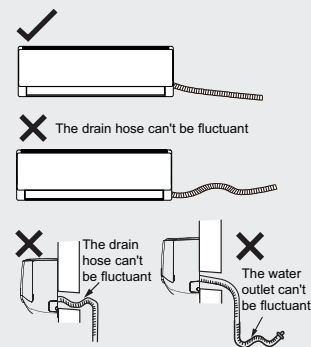

Fig.26

- The water outlet can't be placed in water in order to drain smoothly.  
(As shown in Fig.27)

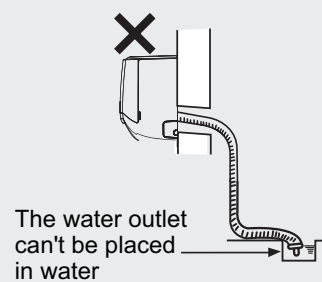

Fig.27

## 8.7 Vacuum Pumping and Leak Detection

### 1. Use Vacuum Pump

- (1) Remove the valve caps on the liquid valve and gas valve and the nut of refrigerant charging vent.
- (2) Connect the charging hose of piezometer to the refrigerant charging vent of gas valve and then connect the other charging hose to the vacuum pump.
- (3) Open the piezometer completely and operate for 10-15min to check if the pressure of piezometer remains in  $-0.1\text{MPa}$ .
- (4) Close the vacuum pump and maintain this status for 1-2min to check if the pressure of piezometer remains in  $-0.1\text{MPa}$ . If the pressure increases, there may be leakage.
- (5) Remove the piezometer, open the valve core of liquid valve and gas valve completely with inner hexagon spanner.
- (6) Tighten the screw caps of valves and refrigerant charging vent.(As shown in Fig.28)

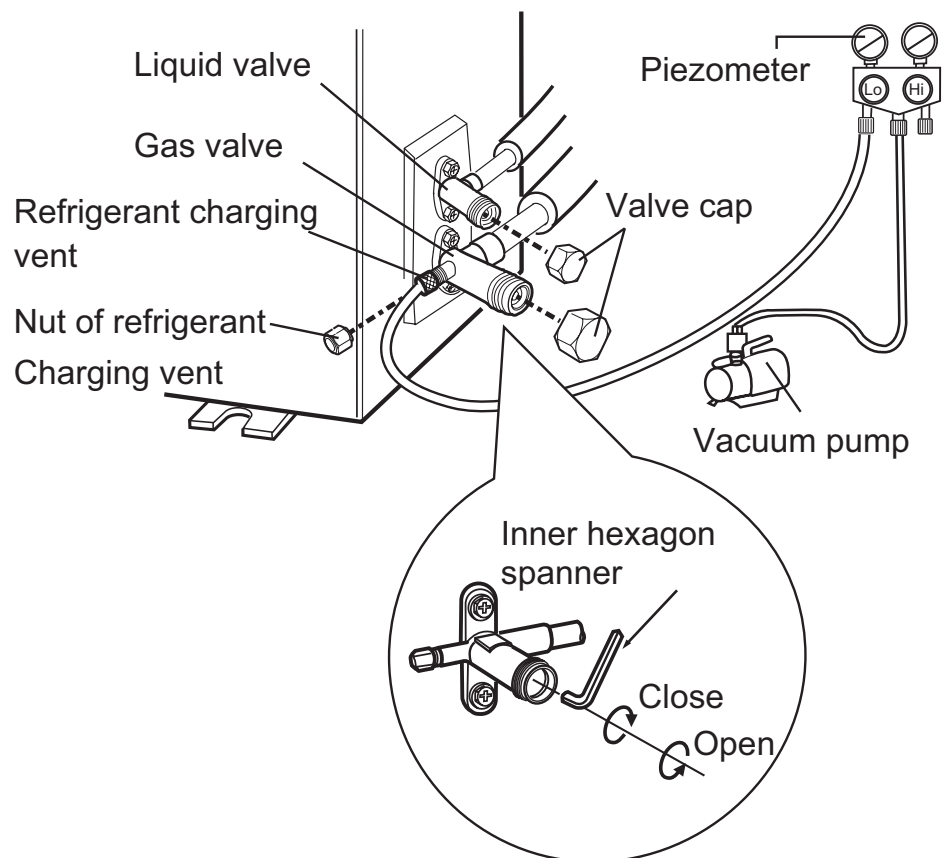

Fig.28

## **2. Leakage Detection**

- (1) With leakage detector:

Check if there is leakage with leakage detector.

- (2) With soap water:

If leakage detector is not available, please use soap water for leakage detection. Apply soap water at the suspected position and keep the soap water for more than 3min. If there are air bubbles coming out of this position, There's a leakage.

## 8.8 Check after Installation and Test Operation

### 1. Check after Installation

Check according to the following requirement after finishing installation.

NO.	Items to be checked	Possible malfunction
1	Has the unit been installed firmly?	The unit may drop, shake or emit noise.
2	Have you done the refrigerant leakage test?	It may cause insufficient cooling (heating) capacity.
3	Is heat insulation of pipeline sufficient?	It may cause condensation and water dripping.
4	Is water drained well?	It may cause condensation and water dripping.
5	Is the voltage of power supply according to the voltage marked on the nameplate?	It may cause malfunction or damage the parts.
6	Is electric wiring and pipeline installed correctly?	It may cause malfunction or damage the parts.
7	Is the unit grounded securely?	It may cause electric leakage.
8	Does the power cord follow the specification?	It may cause malfunction or damage the parts.
9	Is there any obstruction in air inlet and air outlet?	It may cause insufficient cooling (heating) capacity.
10	The dust and sundries caused during installation are removed?	It may cause malfunction or damaging the parts.
11	The gas valve and liquid valve of connection pipe are open completely?	It may cause insufficient cooling (heating) capacity.
12	Is the inlet and outlet of piping hole been covered?	It may cause insufficient cooling(heating) capacity or waster eletricity.

## 2. *Test Operation*

### (1) Preparation of test operation

- The client approves the air conditioner installation.
- Specify the important notes for air conditioner to the client.

### (2) Method of test operation

- Put through the power, press ON/OFF button on the remote controller to start operation.
- Press MODE button to select AUTO, COOL, DRY, FAN and HEAT to check whether the operation is normal or not.
- If the ambient temperature is lower than 16°C, the air conditioner can't start cooling.

# 9. Maintenance

## 9.1 Error Code List

Error code	Malfunction name	Possible causes
E6	Communication error between IDU with ODU	Please refer to "Communication Error".
H5	IPM protection	Please refer to "IPM Protection".
L3 LA	Outdoor fan error	<ol style="list-style-type: none"><li>1. Motor or motor wire is damaged;</li><li>2. Main board of ODU is damaged;</li><li>3. The fan blade is clogged or loose.</li></ol>
H6	Operating error of IDU motor	<ol style="list-style-type: none"><li>1. Motor terminal is not well connected;</li><li>2. The motor is damaged;</li><li>3. Main board of IDU is damaged.</li></ol>
H7	PFC protection	<ol style="list-style-type: none"><li>1. Main board of ODU is damaged;</li><li>2. Poor power grid quality, with oscillation or significant fluctuations in AC input voltage;</li><li>3. Unreliable connections of the air conditioner's power plug, terminal board, or reactor, leading to arcing;</li><li>4. Excessive dirt on indoor and outdoor heat exchangers or blockage of air outlets.</li></ol>

Error code	Malfunction name	Possible causes
<b>H7</b>	<b>Compressor out of step</b>	<ol style="list-style-type: none"> <li>1. Abnormal power supply voltage;</li> <li>2. Condenser or evaporator is dirty or clogged;</li> <li>3. Inlet and outlet air of indoor unit or outdoor unit is not smooth;</li> <li>4. System piping blockage, valves are not open;</li> <li>5. Excessive refrigerant causing excessive system pressure;</li> <li>6. Poor wiring contact;</li> <li>7. Main board is damaged;</li> <li>8. Compressor is damaged;</li> </ol> <p>Please refer to "Compressor out of step".</p>
<b>F0</b>	<b>Refrigerant lack protection, refrigerant circulation stop protection</b>	<ol style="list-style-type: none"> <li>1. The connection pipe between the IDU and ODU is damaged or the connection point is aged and loose, leading to refrigerant leakage;</li> <li>2. The liquid valve / air valve is aged and damaged, causing abnormal opening and closing control, which leads to pipeline blockage;</li> <li>3. The temperature sensor is damaged or aged, resulting in inaccurate temperature sampling and false error reporting.</li> </ol>
<b>PH</b>	<b>High DC bus voltage</b>	<ol style="list-style-type: none"> <li>1. The AC supply voltage is too high, for example, the AC supply voltage exceeds 300V;</li> <li>2. Poor power quality, with abnormal oscillation in the AC supply voltage;</li> <li>3. The main board is damaged.</li> </ol>
<b>PL</b>	<b>Low DC bus voltage</b>	<ol style="list-style-type: none"> <li>1. AC power supply voltage is too low, for example, the AC power supply voltage is less than 90V;</li> <li>2. Abnormal unit wiring, such as loose connection wires;</li> <li>3. Main board of outdoor unit is damaged;</li> </ol>

Error code	Malfunction name	Possible causes
<b>E8</b>	<b>High-temperature protection</b>	<p>Cooling:</p> <ol style="list-style-type: none"> <li>1. The condenser of the outdoor unit is dirty or clogged, leading to poor heat exchange;</li> <li>2. Insufficient space or obstacles at the air inlet and outlet of the outdoor unit cause poor air circulation;</li> <li>3. The fan blade of the outdoor unit is broken, falling off or the motor is damaged;</li> <li>4. The temperature sensor of the outdoor unit condenser is damaged, or the main board is damaged, leading to inaccurate temperature sampling.</li> </ol> <p>Heating:</p> <ol style="list-style-type: none"> <li>1. The indoor unit evaporator is dirty or clogged, leading to poor heat exchange;</li> <li>2. Insufficient space or obstructions at the air outlets of the indoor unit cause poor air intake and exhaust;</li> <li>3. The fan blade of the outdoor unit is broken, falling off;</li> <li>4. The temperature sensor of the indoor unit evaporator is damaged, or the main board is damaged, leading to inaccurate temperature sampling.</li> </ol>
<b>[5</b>	<b>Jumper cap error</b>	<ol style="list-style-type: none"> <li>1. The jumper cap of indoor unit is not installed, or the jumper cap is not properly installed;</li> <li>2. The jumper cap has poor contact and is not properly installed.</li> </ol>
<b>[4</b>	<b>Jumper cap of ODU</b>	The jumper cap of outdoor unit is not installed, or the jumper cap is not properly installed.
<b>F1</b>	<b>Open/short circuit of indoor temperature sensor</b>	<ol style="list-style-type: none"> <li>1. Temperature sensor is damaged (refer to attachment "Table 1");</li> <li>2. Temperature sensor is not connected or in poor contact.</li> </ol>

Error code	Malfunction name	Possible causes
<b>F2</b>	<b>Open/short circuit of temperature sensor of indoor evaporator</b>	<ol style="list-style-type: none"><li>1. Temperature sensor is damaged (refer to attachment "Table 2");</li><li>2. Temperature sensor is not connected or in poor contact.</li></ol>
<b>F3</b>	<b>Open/short circuit of outdoor temperature sensor</b>	<ol style="list-style-type: none"><li>1. Temperature sensor is not connected or is damaged; (refer to attachment "Table 1");</li><li>2. Temperature sensor wire is damaged, or is short-circuited to the copper tube or outer case;</li><li>3. The main board of ODU is damaged.</li></ol>
<b>F4</b>	<b>Open/short circuit of temperature sensor of outdoor condenser</b>	<ol style="list-style-type: none"><li>1. Temperature sensor is not connected or is damaged; (refer to attachment "Table 2");</li><li>2. Temperature sensor wire is damaged, or is short-circuited to the copper tube or outer case;</li><li>3. The main board of ODU is damaged.</li></ol>
<b>F5</b>	<b>Open/short circuit of temperature sensor</b>	<ol style="list-style-type: none"><li>1. Temperature sensor is not connected or is damaged; (refer to attachment "Table 3");</li><li>2. Temperature sensor wire is damaged, or is short-circuited to the copper tube or outer case;</li><li>3. The main board of ODU is damaged.</li></ol>
<b>U8</b>	<b>Indoor unit zero-crossing signal error</b>	<ol style="list-style-type: none"><li>1. The power supply is abnormal;</li><li>2. Main board of IDU is damaged.</li></ol>

Error code	Malfunction name	Possible causes
E5	Overcurrent protection	<ol style="list-style-type: none"> <li>1. Unstable power supply voltage;</li> <li>2. Power supply voltage is too low;</li> <li>3. Condenser or evaporator is dirty or clogged;</li> <li>4. Inlet and outlet air of IDU or ODU is not smooth;</li> <li>5. System pipeline is blocked, valves are not open;</li> <li>6. Excessive refrigerant leads to excessive system pressure;</li> <li>7. Main board is damaged;</li> <li>8. Compressor is damaged;</li> </ol> Please refer to "Overcurrent protection".
H3	Compressor overload protection	<ol style="list-style-type: none"> <li>1. The connection between the overload connection wire and the main board or the overload protector is unreliable, and the terminal is loose;</li> <li>2. The overload protector is damaged, under normal circumstances, the impedance at both ends of the test overload protector should be less than 1Ω;</li> <li>3. The overload connection wire is damaged, resulting in the short circuit of wire;</li> <li>4. Refrigerant leakage or system blockage;</li> <li>5. The main board is damaged.</li> </ol>
EA	Refrigerant leak alarm	There may be refrigerant leakage in the unit.
FE	Refrigerant sensor error	Service life of refrigerant expires or is damaged.
b7	Open/short circuit of temperature sensor of air valve	<ol style="list-style-type: none"> <li>1. Temperature sensor is not connected or is damaged; (refer to attachment "Table 2");</li> <li>2. Temperature sensor wire is damaged, or is short-circuited to the copper tube or outer case;</li> <li>3. The main board of ODU is damaged.</li> </ol>

Error code	Malfunction name	Possible causes
b5	Open/short circuit of temperature sensor of liquid valve	<ol style="list-style-type: none"> <li>1. Temperature sensor is not connected or is damaged; (refer to attachment "Table 2");</li> <li>2. Temperature sensor wire is damaged, or is short-circuited to the copper tube or outer case;</li> <li>3. The main board of ODU is damaged.</li> </ol>
E1	System high pressure protection	<ol style="list-style-type: none"> <li>1. The connection between the wiring and the main board or high-pressure protection switch is unreliable, with loose terminals;</li> <li>2. The high-pressure protection switch is damaged; under normal circumstances, the impedance between the two ends of the high-pressure protection switch should be less than 1Ω;</li> <li>3. Abnormalities such as dirt blockage in the condenser or evaporator, poor air circulation, excessive refrigerant, or blockages in the system piping can lead to excessively high system pressure;</li> <li>4. The main board is damaged.</li> </ol>
E3	Low pressure protection/system low pressure protection/compressor low pressure protection	<ol style="list-style-type: none"> <li>1. Low pressure switch is damaged;</li> <li>2. System refrigerant leakage.</li> </ol>
E4	High exhaust temperature protection of compressor	Please refer to "Compressor overload protection"
E7	Mode conflict	When the free match system is faulted, some indoor units will conduct heating mode, while others will conduct cooling, dry mode or air supply mode, causing a mode conflict.
EE	Read EEPROM error	Main board of ODU is damaged.

Error code	Malfunction name	Possible causes
F0	Refrigerant recovery mode	Recovery of refrigerant. The mode is conducted during maintenance.
HE	Compressor demagnetization protection	<ol style="list-style-type: none"> <li>1. Main board of ODU is damaged;</li> <li>2. Compressor is damaged.</li> </ol>
L9	High power protection	Please refer to "High temperature, overload, high power, system error".
Lc	Startup failure	Please refer to "Startup failure".
Ld	Compressor phase-loss protection	<ol style="list-style-type: none"> <li>1. Poor wiring contact of compressor;</li> <li>2. Main board of ODU is damaged;</li> <li>3. Compressor is damaged.</li> </ol>
PS	Over-phase current protection of compressor	Please refer to "IPM Protection".
oE	Undefined ODU error	Please refer to "Undefined ODU error".
P6	Communication error between drive board and main control	<ol style="list-style-type: none"> <li>1. Poor connection between drive board and main board;</li> <li>2. Drive board is damaged;</li> <li>3. Main board of ODU is damaged.</li> </ol>
P7	Circuit error of module temperature sensor	Main board of ODU is damaged.
P8	High-temperature protection of module	<ol style="list-style-type: none"> <li>1. Air inlet/outlet of ODU is dirty and clogged;</li> <li>2. IPM screw of main board is not well installed or the radiator is not well installed, or the main board is damaged.</li> </ol>

Error code	Malfunction name	Possible causes
PF	Error of ambient temperature sensor on drive board	<ol style="list-style-type: none"> <li>1. Poor contact of ambient temperature sensor of driver board;</li> <li>2. Error of ambient temperature sensor on drive board.</li> </ol>
PU	Capacitor charging error	<ol style="list-style-type: none"> <li>1. Main board of ODU is damaged;</li> <li>2. Wiring error of ODU or low power supply voltage.</li> </ol>
rF	RF module error	<ol style="list-style-type: none"> <li>1. Poor contact of the RF module connection wire;</li> <li>2. RF module error;</li> <li>3. Abnormality in the RF module interface circuit of main board.</li> </ol>
U1	Compressor phase current detection circuit error	Main board of ODU is damaged.
U2	Compressor phase-loss Protection	<ol style="list-style-type: none"> <li>1. Poor wiring contact of compressor;</li> <li>2. Main board of ODU is damaged;</li> <li>3. Compressor is damaged.</li> </ol>
U3	DC bus voltage drop error	Unstable power voltage with large fluctuation.
U5	Current detection error of whole unit	<ol style="list-style-type: none"> <li>1. The whole unit lacks refrigerant;</li> <li>2. The circuit on the control board of ODU has failed, the control board shall be replaced.</li> </ol>
U7	4-way valve switchover error	<ol style="list-style-type: none"> <li>1. Power voltage is below AC175V;</li> <li>2. Loose or broken wires at the four-way valve terminal;</li> <li>3. Four-way valve is damaged, please replace the four-way valve.</li> </ol>
U9	ODU zero-crossing error	Main board of ODU is damaged.

Error code	Malfunction name	Possible causes
<b>E2</b>	<b>Evaporator anti-freeze protection</b>	It's not an error code, it belongs to the status code during the cooling process.
<b>E9</b>	<b>Anti-cold wind protection</b>	It's not an error code, it belongs to the status code during the heating process.
<b>LP</b>	<b>IDU and ODU do not match</b>	Capacity of IDU and ODU do not match.
<b>FC</b>	<b>Micro-switch error</b>	<ol style="list-style-type: none"><li>1. The control motor of sliding door is abnormally connected to the main board;</li><li>2. The sliding door is jammed;</li><li>3. The photoelectric detection plate of sliding door is faulted.</li></ol>
<b>JF</b>	<b>Communication error between IDU and detective board"</b>	<ol style="list-style-type: none"><li>1. Poor connection between the indoor unit and the detection plate;</li><li>2. Main board of IDU is damaged;</li><li>3. Detection plate is damaged.</li></ol>
<b>L1</b>	<b>Humidity sensor error</b>	<ol style="list-style-type: none"><li>1. Check if the WIFI communication is normal, please refer to JF troubleshooting;</li><li>2. The sensor is damaged;</li><li>3. The display board is damaged.</li></ol>
	<b>Defrosting</b>	It's not an error code, it belongs to the status code during the heating process.

## 9.2 Procedure of Troubleshooting

### *E6: Communication Error Between IDU with ODU*

#### 1. Communication Error between IDU with ODU

- (1) Cooling/dehumidification: Compressor and outdoor fan stop running;
- (2) Heating: All loads stop running;
- (3) Principle: The indoor and outdoor units cannot establish communication or the established communication data is abnormal.

#### 2. Possible causes

- (1) Electric circuit of main board is damaged;
- (2) Wire connection between IDU and ODU is abnormal, or wire connection between terminal board and main board is abnormal;
- (3) The neutral and live wires are connected in reverse;
- (4) The power grid is abnormal.

#### 3. Troubleshooting

- (1) Check whether the connection wire of the indoor and outdoor units is damaged;
- (2) Check whether the power cord and communication wire of main board of the indoor and outdoor unit are damaged;
- (3) Check whether the wiring sequence is correct, whether the neutral and live wires are connected in reverse, and whether the power cord and communication wire are not connected properly;
- (4) Check whether the LED indicator on the main board of ODU flashes according to the normal rules;
- (5) Check whether the coil of ODU is corroded and short-circuited, causing damage to the main board.

#### 4. Specific troubleshooting steps:

1. Using the after-sales tester GT2A3Ad can identify faults more conveniently and quickly;
  - (1) If it replaces the IDU to communicate with the ODU, and the E6 error occurs, it means the main board of ODU is abnormal;

- (2) If it replaces the ODU to communicate with the IDU, and the E6 error occurs, it means the main board of IDU is abnormal;
- (3) If no E6 error occurs, it means that the connection line between the indoor unit and the outdoor unit is abnormal.

2. Manual Detection

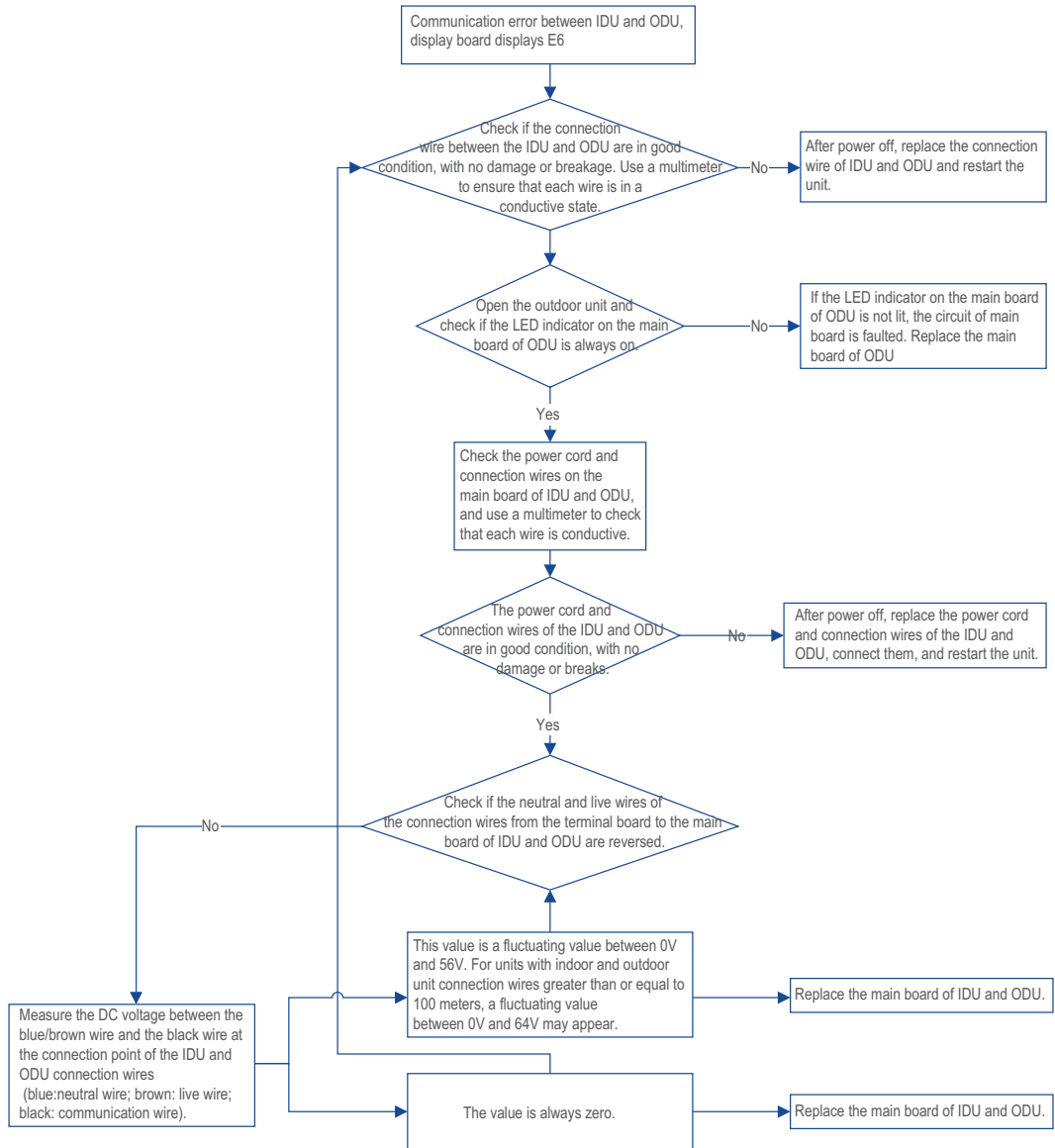

**NOTE:**

The method for detecting the communication circuit of ODU of the inverter split type unit and the floor standing type unit: disconnect the indoor and outdoor communication wire, and measure the voltage between COM and N on the control board of the ODU (DC gear, about 56V is normal).

## **H5: IPM Protection**

### **1. Error description**

When the compressor is running, detect the current flowing through the compressor control module (IPM). If the current exceeds the set value (the set value varies for different models), an H5 IPM current protection error is reported.

### **2. Possible causes**

- (1) Abnormal power supply voltage;
- (2) Condenser or evaporator is dirty or clogged;
- (3) Inlet and outlet air of IDU or ODU is not smooth;
- (4) System pipe is blocked, valves are not open;
- (5) Excessive refrigerant causing excessive system pressure;
- (6) Poor wire contact;
- (7) Main board is damaged;
- (8) Compressor is damaged.

### 3. Troubleshooting

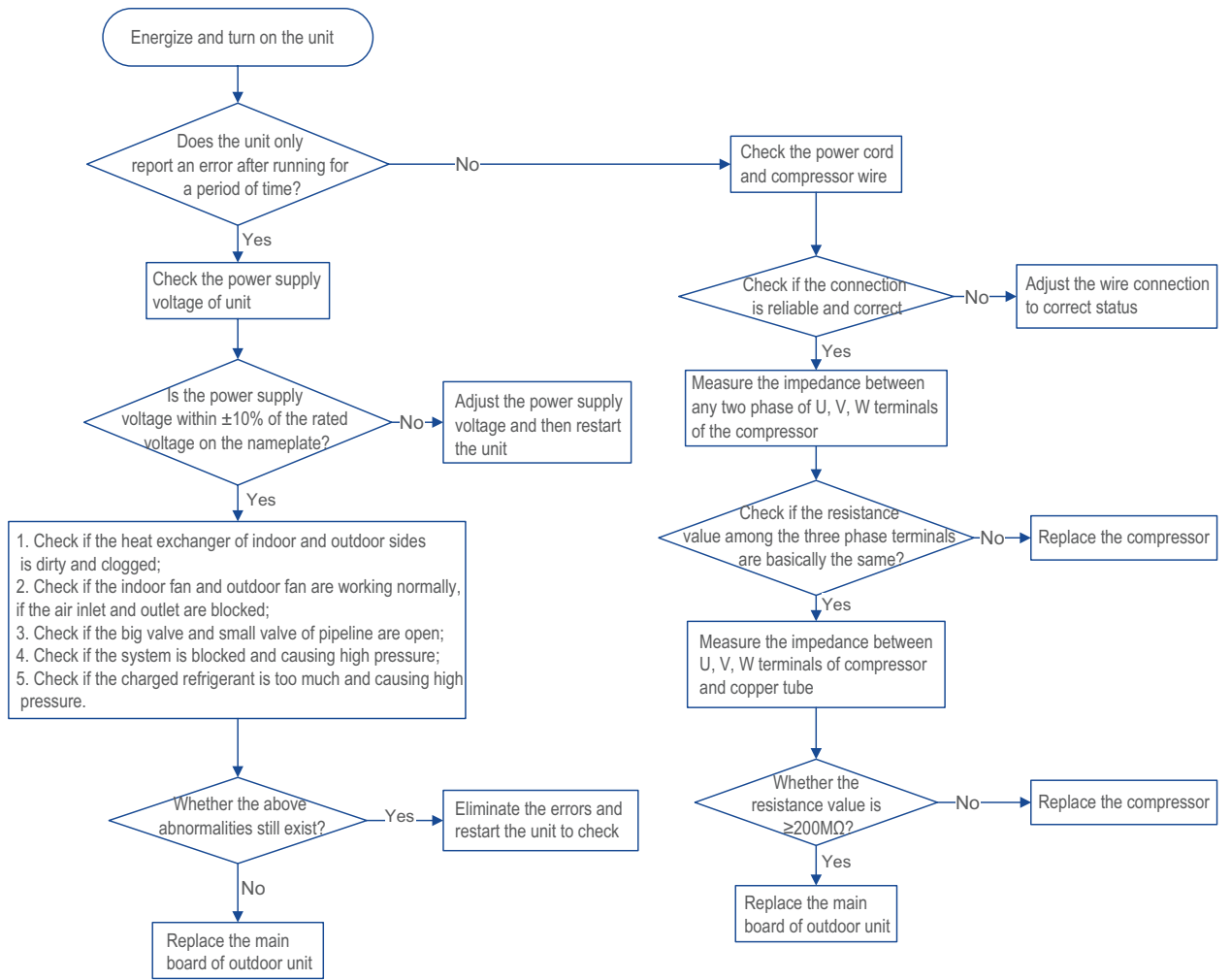

## **L3: Outdoor Fan Error**

### **1. Outdoor Fan Error**

- (1) Cooling/dehumidification: All loads stop running except the indoor fan;
- (2) Heating: All loads stop running;
- (3) Principle: The fan reports a major error every 6 minor errors (such as fan out of step, fan blockage, fan overload, etc.). The unit stops operation and then it will resume operation after 3min. After reporting 6 major errors, L3 will be displayed and the unit can't resume operation;

### **2. Possible causes**

- (1) The wire connection between the fan and the main board is unreliable, with loose terminals;
- (2) The fan wiring is damaged, causing an open circuit;
- (3) The main board is damaged;
- (4) The fan is damaged;
- (5) The fan is blocked or the blades are loose due to external factors.

### **3. Solutions**

Check if the wiring is damaged and if the connection is reliable; check if the fan is damaged; check if the fan is blocked or the blades are loose.

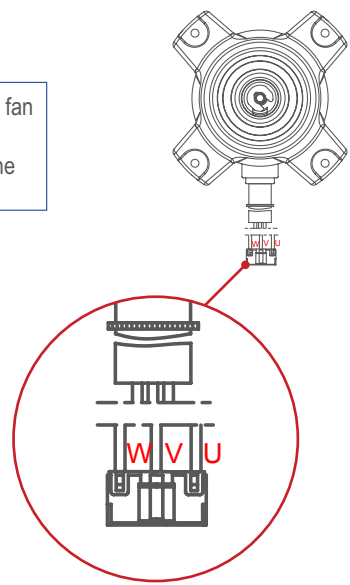
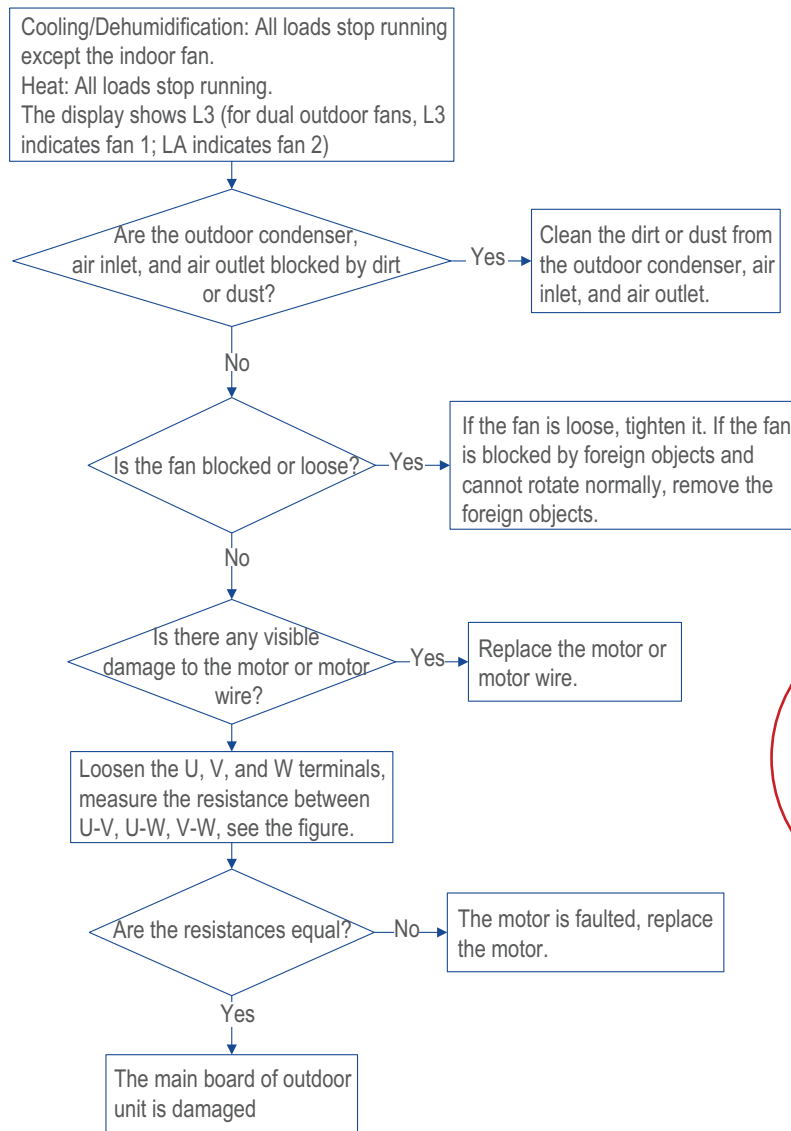

## H6: Operating Error of Indoor Unit Motor

Possible causes:

- (1) Motor terminal or feedback terminal is not properly connected;
- (2) Motor is damaged;
- (3) Main board of IDU is damaged.

### 1. DC motor

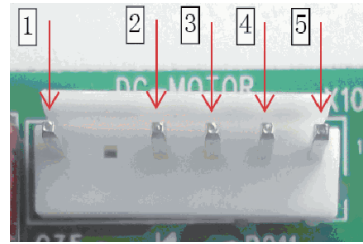
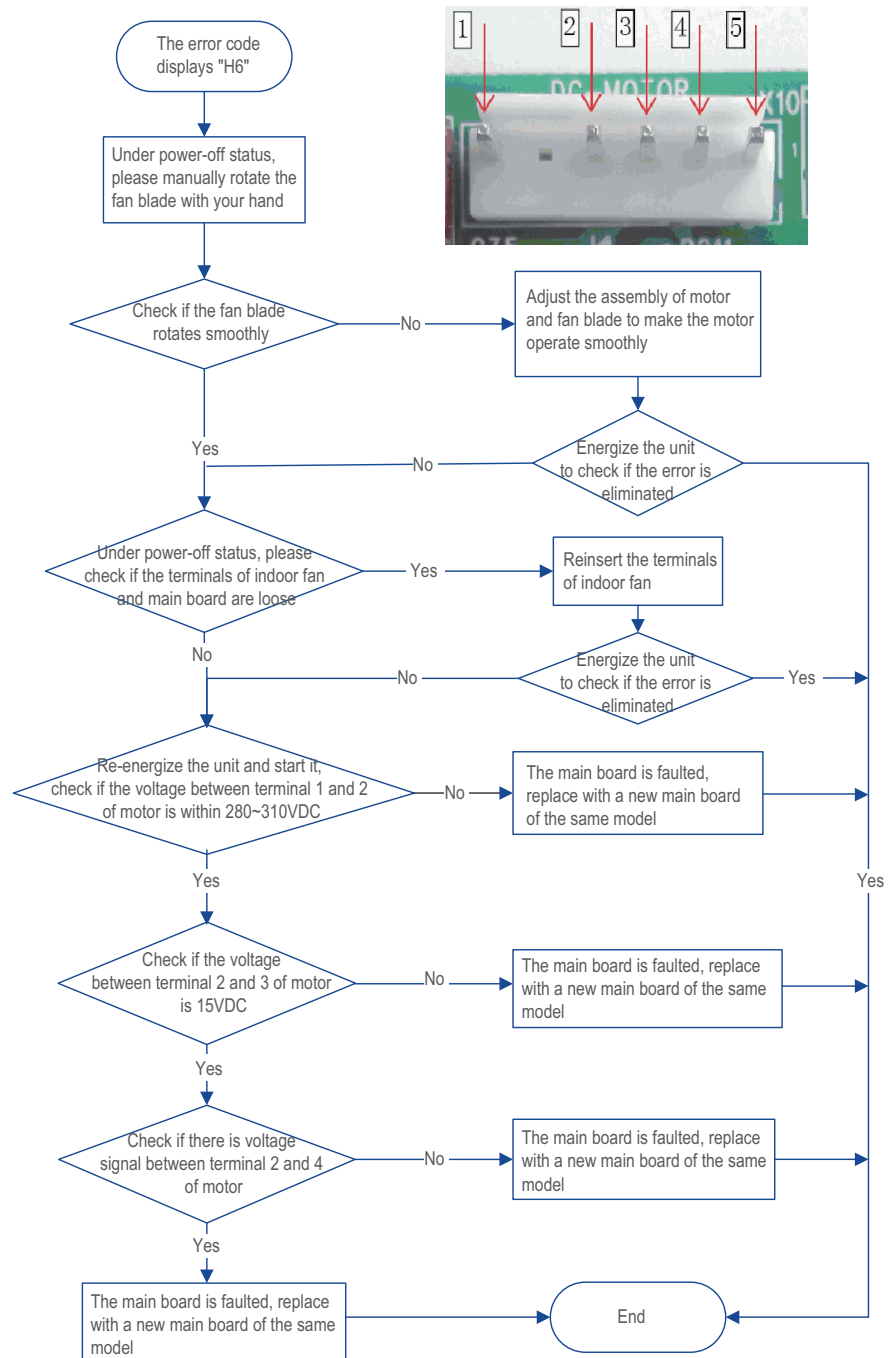

## 2. PG motor

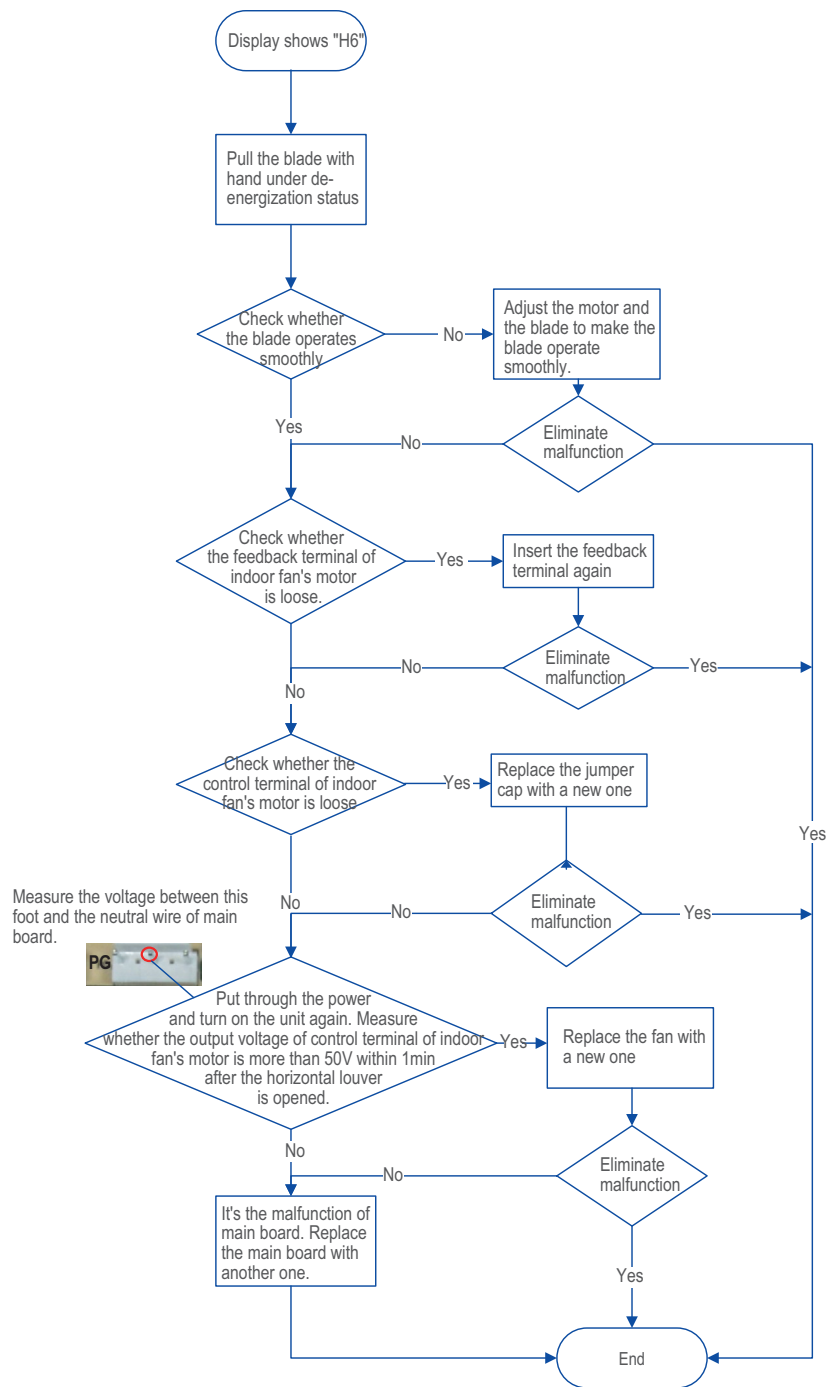

## **HC: PFC Protection**

### **1. Error description**

- (1) Cooling/dehumidification: Compressor and outdoor fan stop running;
- (2) Heating: All loads stop running;
- (3) Principle: The main program detects that the instantaneous input current of the PFC circuit is too high.

### **2. Possible causes**

- (1) The main board of the outdoor unit is damaged;
- (2) The power supply used is an inferior power supply, and the input voltage fluctuates and the current is too large;
- (3) The power cord is not well connected;
- (4) The air inlet of the unit is blocked.

### **3. Troubleshooting**

- (1) Use a multimeter to measure the voltage of the power supply;
- (2) Check whether the connection wire is well connected;
- (3) Check whether the air inlet of the unit is blocked.

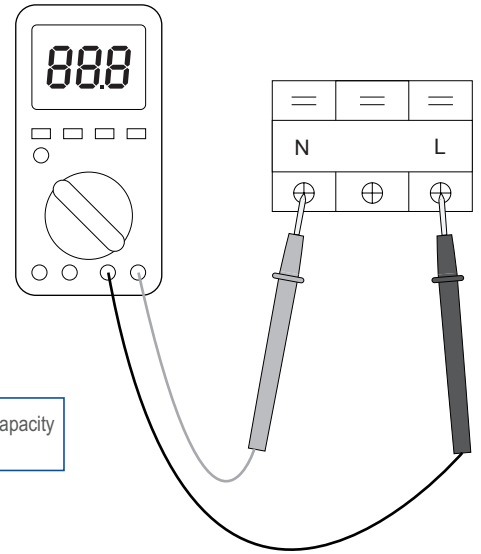
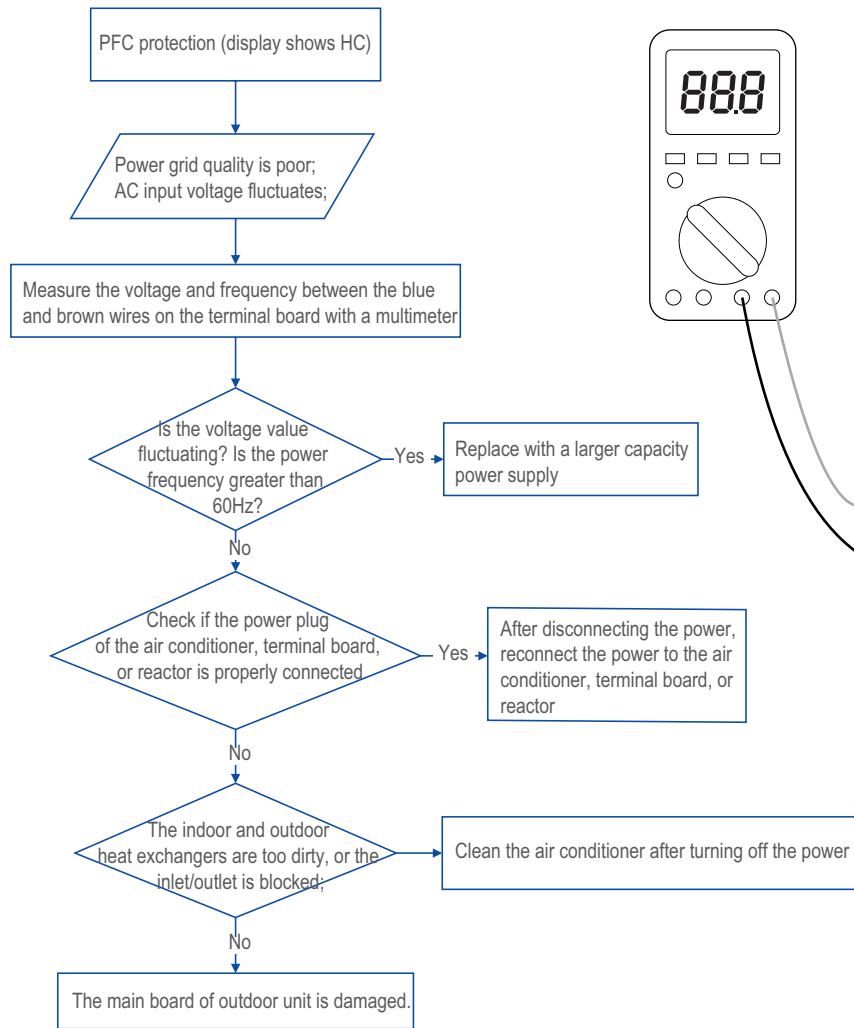

## **H7: Compressor Out of Step**

### **1. Error description**

When the compressor is running, the difference between the actual operating speed and the set speed is detected to exceed the set value (the set value is different for different models), and the H7 compressor out-of-step protection is reported.

### **2. Possible causes**

- (1) The power supply voltage is abnormal;
- (2) The condenser or evaporator is dirty and blocked;
- (3) The air inlet and outlet of the indoor unit or outdoor unit are not smooth;
- (4) The system pipeline is blocked and the valve is not opened;
- (5) Too much refrigerant leads to excessive system pressure;
- (6) Poor wire contact;
- (7) The main board is damaged;
- (8) The compressor is damaged.

### **3. Troubleshooting**

Troubleshoot according to the flow chart.

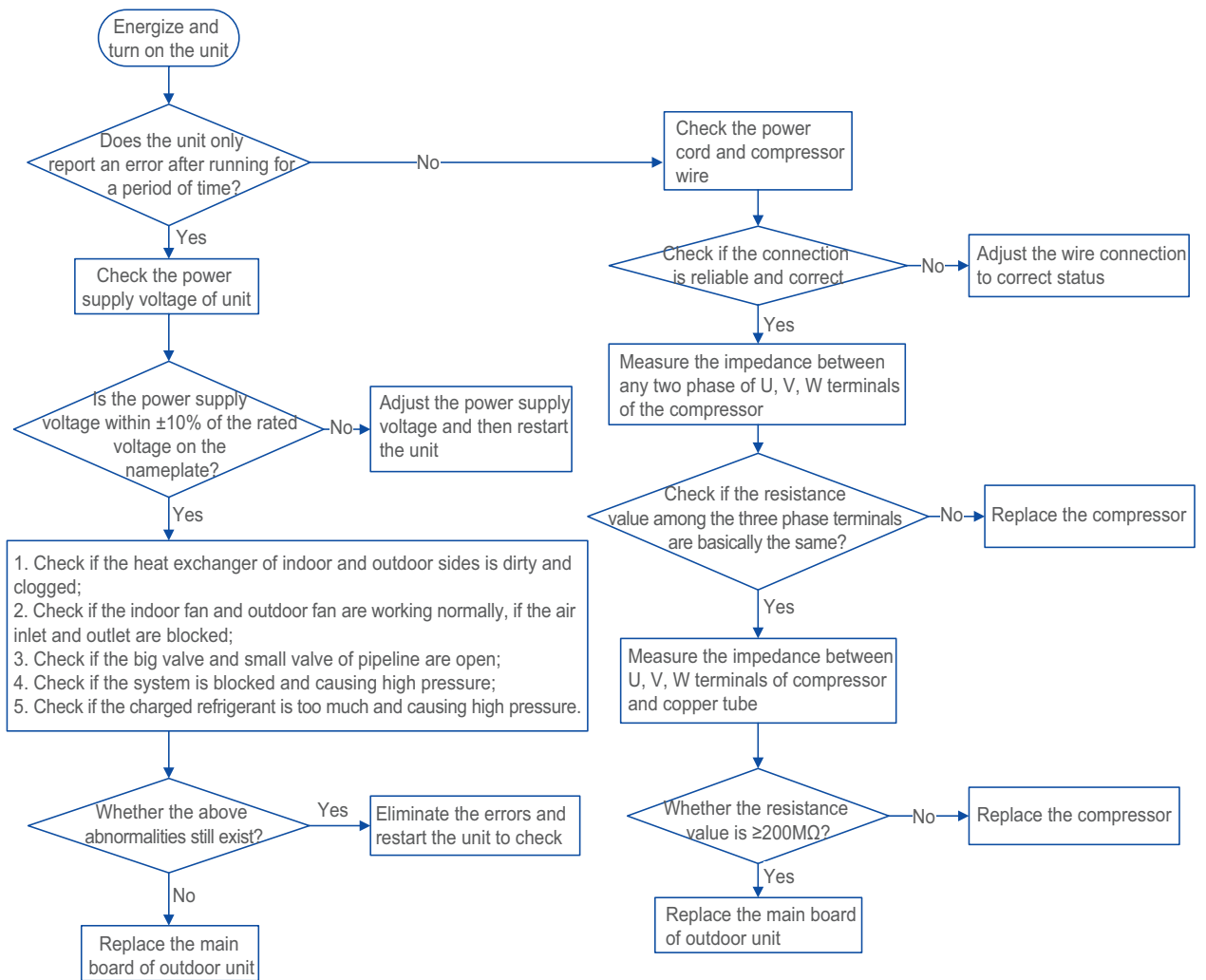

## **F0: Refrigerant Lack Protection, Refrigerant Circulation Stop Protection**

### **1. Error description**

This error code will be displayed when the main board of the indoor unit detects that the temperature difference between the inner tube and the inner ring is too small for a period of time.

### **2. Possible causes**

- (1) The connecting pipe of the IDU and ODU is damaged or the connection is aging and loose, resulting in the leakage of refrigerant;
- (2) The liquid valve/air valve is aging and damaged, resulting in abnormal opening and closing control and pipeline blockage;
- (3) The temperature sensor is inaccurate and false alarm due to the damage and aging of the temperature sensor.

### **3. Troubleshooting**

Check whether the temperature sensor and pipeline are damaged, and add refrigerant.

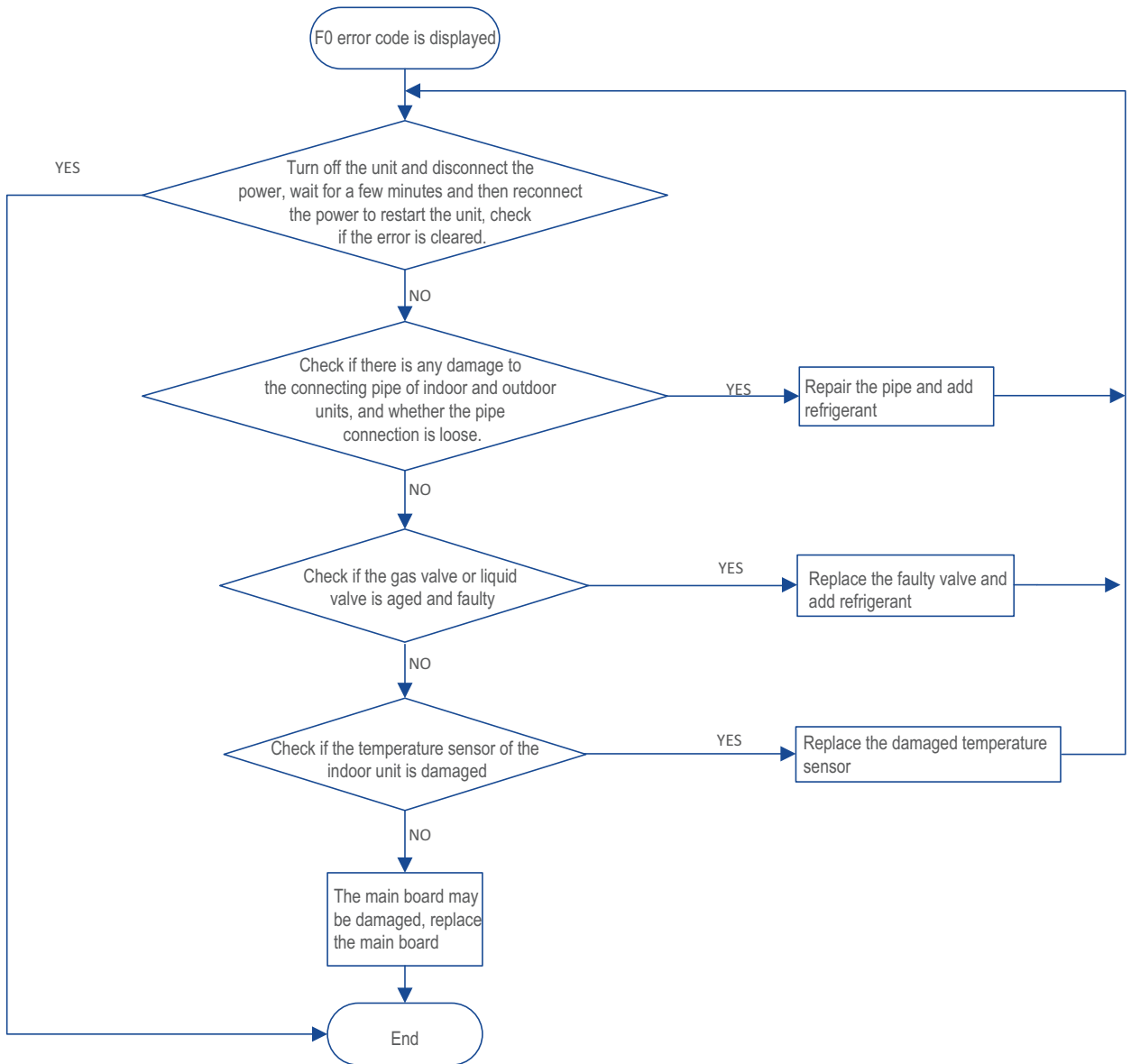

## PH: High DC Bus Voltage

### 1. Error description

When the compressor is running, the DC bus voltage of the main board is detected, if the voltage value is higher than a certain value (such as 425-445V, the value is different due to different models), and it will report the high DC bus voltage protection.

### 2. Possible causes

- (1) The AC power supply voltage is too high, such as the AC power supply voltage is greater than 300V;
- (2) The power supply quality is poor, and the AC power supply voltage has abnormal fluctuation;
- (3) The main board is damaged.

### 3. Troubleshooting

Troubleshoot according to the flow chart.

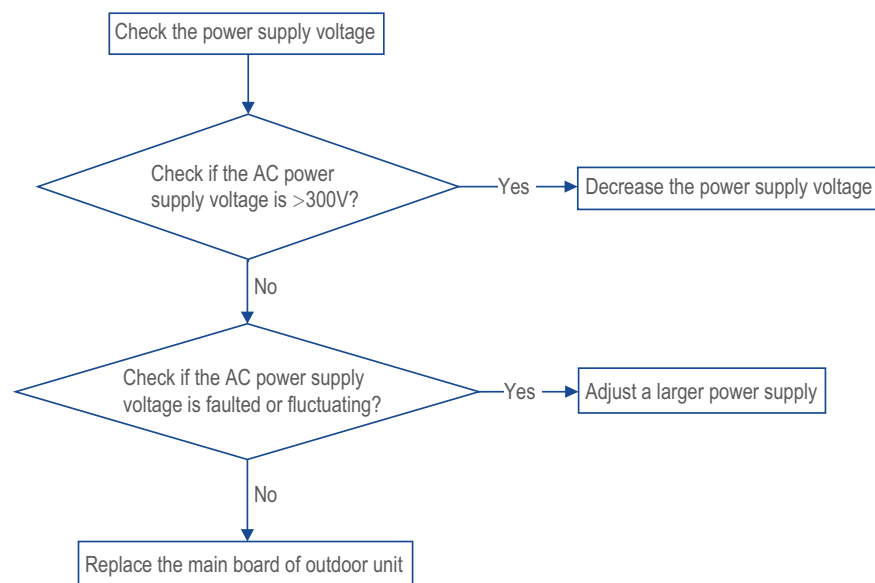

## PL: Low DC Bus Voltage

### 1. Error description

When the compressor is running, the DC bus voltage is detected, if the voltage value is lower than a certain value (such as 120V~170V, different models), it will report low DC bus voltage protection.

### 2. Possible causes

- (1) The AC power supply voltage is too low, such as the AC power supply voltage is less than 90V;
- (2) The wiring of the unit is abnormal and the connecting wire is loose;
- (3) The main board of outdoor unit is damaged.

### 3. Troubleshooting

Troubleshoot according to the flow chart.

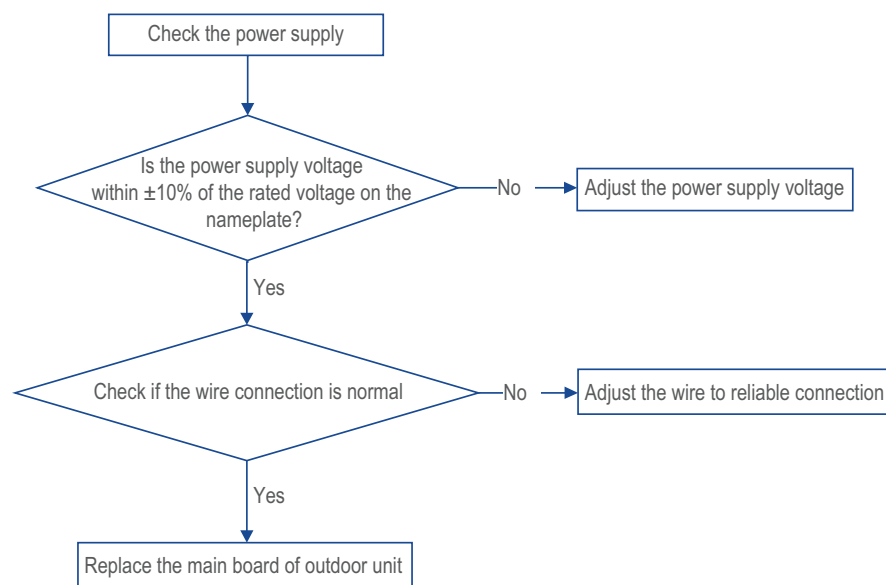

## **E8: High-Temperature Protection**

### **1. Error description**

If the main board detects that the temperature of the evaporator of indoor unit or the condenser of outdoor unit is too high, it will report an E8 high-temperature protection.

### **2. Possible causes**

Cooling:

- (1) The condenser of the outdoor unit is dirty or clogged, leading to poor heat exchange;
- (2) Insufficient space or obstacles at the air inlet and outlet of the outdoor unit cause poor air circulation;
- (3) The fan blade of the outdoor unit is broken or falling off, or the motor is damaged;
- (4) The temperature sensor of condenser of the outdoor unit is damaged, or the main board is damaged, leading to inaccurate temperature sampling.

Heating:

- (1) The evaporator of the indoor unit is dirty or clogged, leading to poor heat exchange;
- (2) Insufficient space or obstacles at the air inlet and outlet of the indoor unit cause poor air circulation;
- (3) The fan blade of the indoor unit is broken or falling off;
- (4) The temperature sensor of evaporator of the indoor unit is damaged, or the main board is damaged, leading to inaccurate temperature sampling.

### **3. Troubleshooting**

Troubleshoot according to the flow chart.

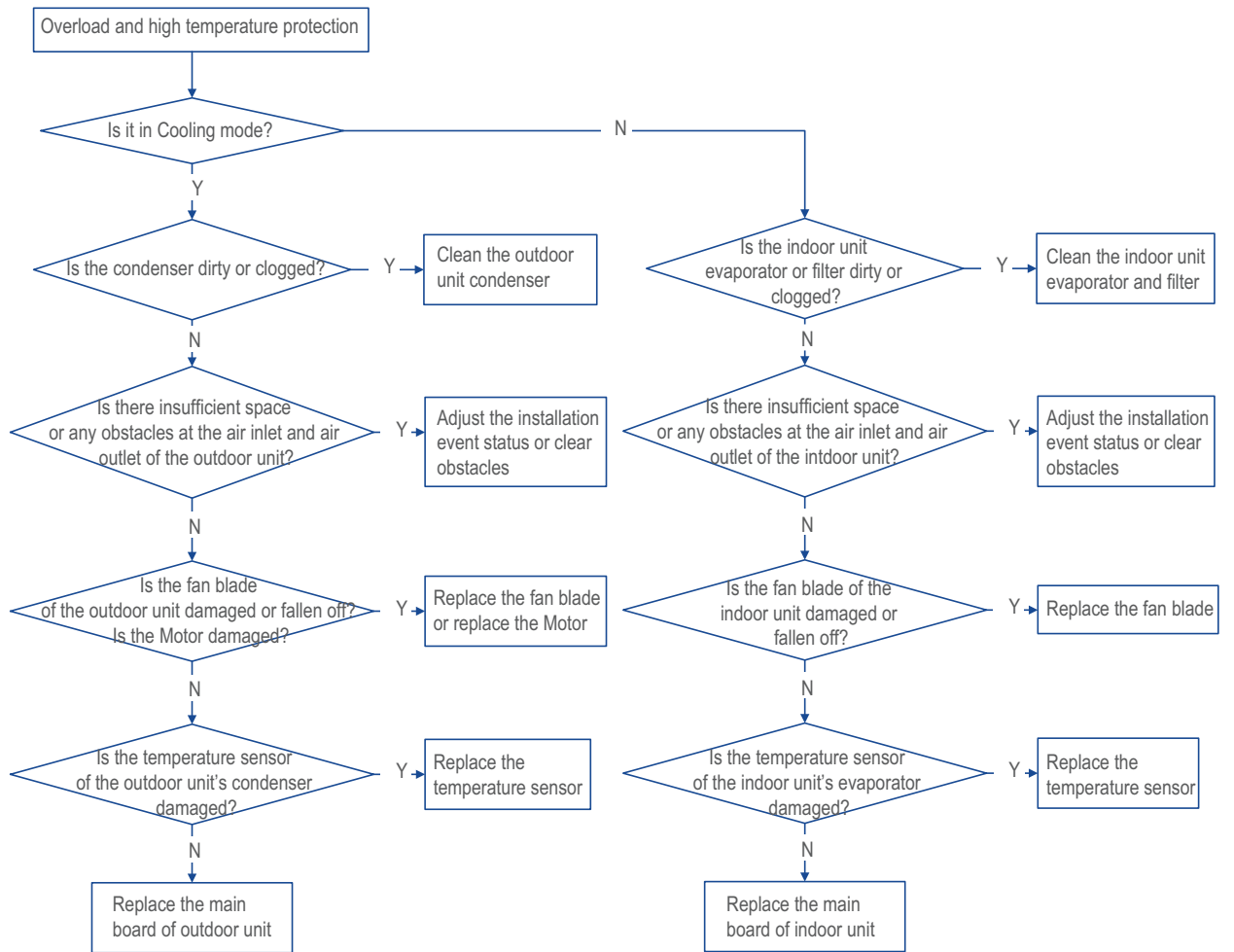

## **C4, C5: Jumper Cap Error**

### **1. Error description**

If the jumper cap cannot be detected when the main board is powered on, the jumper cap error will be reported.

Principle: The jumper cap determines some of the operating parameters of the model, and if the jumper cap is not detected, the air conditioner cannot run.

### **2. Possible causes**

- (1) The main board is not equipped with a jumper cap;
- (2) The jumper cap is not inserted properly.

### **3. Troubleshooting**

- (1) Check whether the main board has installed the jumper cap;
- (2) Check whether the jumper cap of the main board is well inserted.

#### **NOTE:**

C4 refers to outdoor unit; C5 refers to indoor unit.

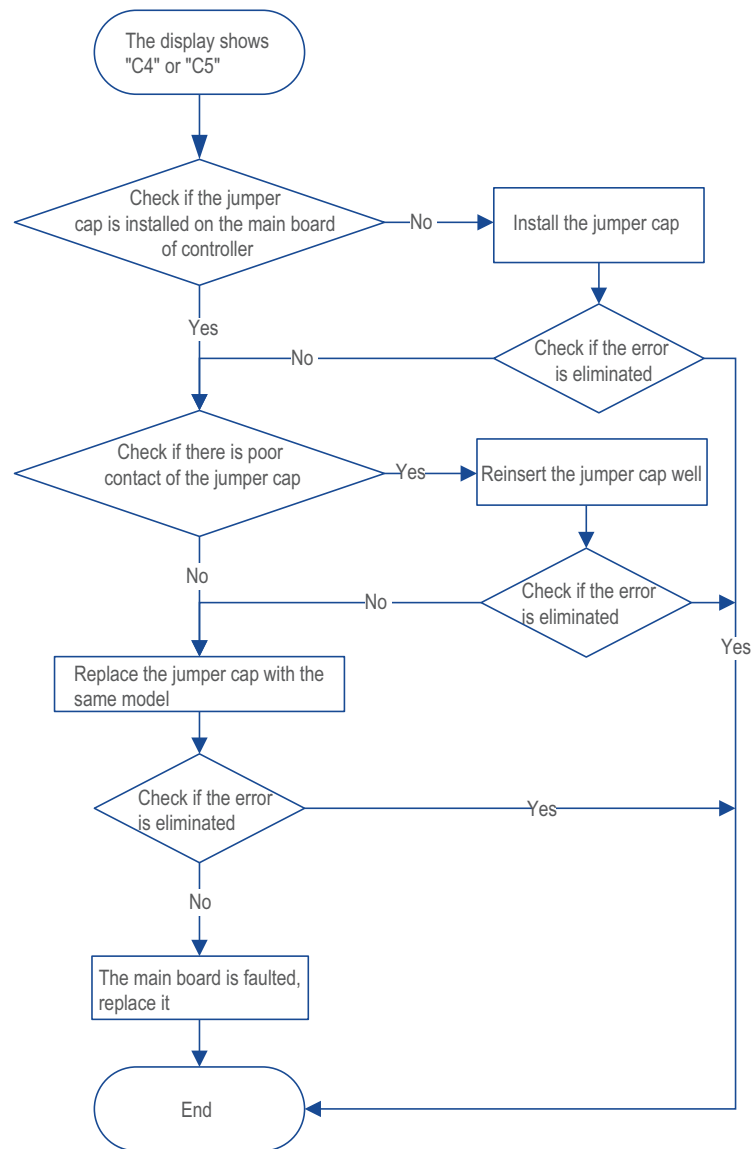

## F 1, F2: Temperature Sensor Error

### 1. Error description

- (1) Cooling/dehumidification: All loads stop operation;
- (2) Heating: All loads stop running.

### 2. Possible causes

- (1) The temperature sensor is damaged;
- (2) The temperature sensor is not connected or has poor contact.

### 3. Troubleshooting

- (1) Check whether the connection between the temperature sensor and the main board is normal;
- (2) Check whether there is an open circuit or a short circuit at both ends of the temperature sensor;
- (3) If there is an abnormality in the circuit of the main board, replace the main board of the same model.

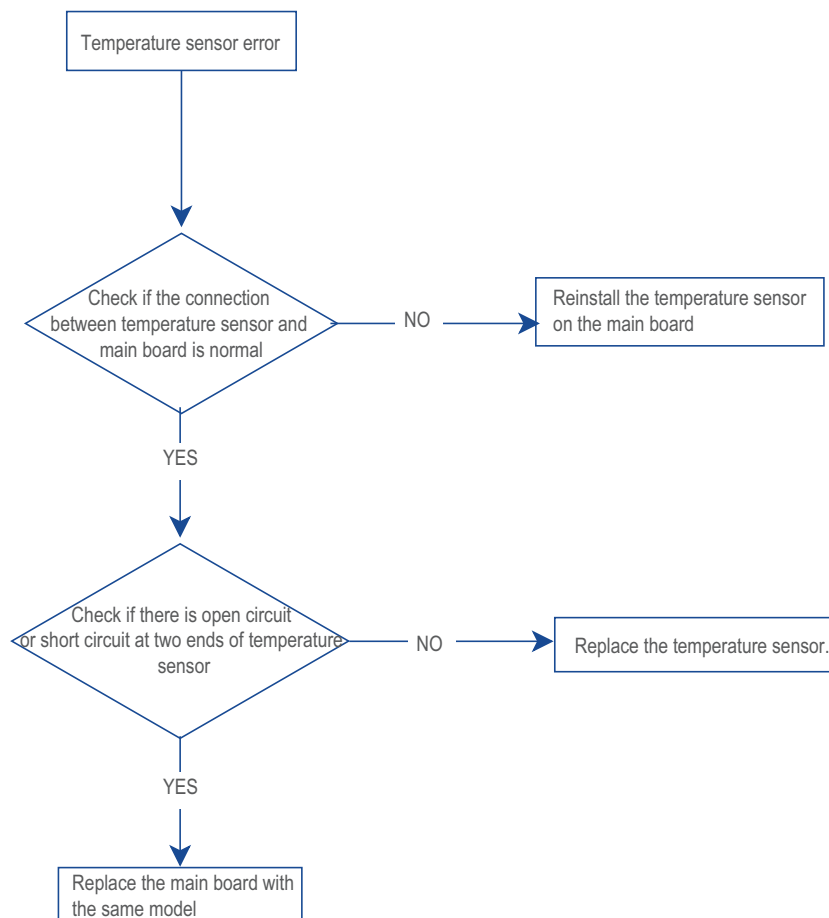

## U8: Indoor Unit Zero-crossing Signal Error

### 1. Error description

After the unit is turned on, if the main board of the indoor unit fails to detect the normal zero-crossing signal continuously within a certain period of time, the zero-crossing error will be reported.

Principle: The main board fails to detect the zero-crossing signal normally, and cannot meet the normal operation requirements of the AC motor.

### 2. Possible causes

- (1) The power grid is abnormal;
- (2) The main board is damaged.

### 3. Troubleshooting

- (1) Check whether the connection of the power cord is reliable;
- (2) Check whether the main board is damaged.

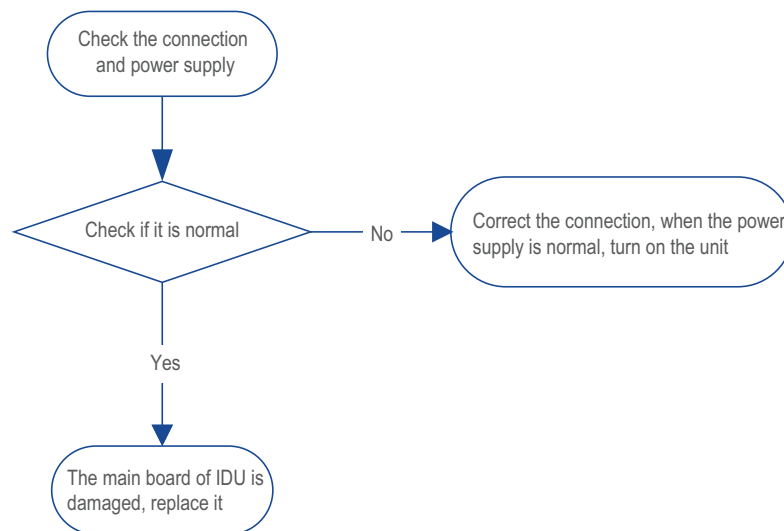

## **E5: Overcurrent Protection**

### **1. Error description**

During the operation of the air conditioner, the AC input current of the whole unit is detected, and when the detected current exceeds the set value (the set value is different for different models), the E5 overcurrent protection of the whole unit will be reported.

### **2. Possible causes**

- (1) The power supply voltage is unstable;
- (2) The power supply voltage is too low;
- (3) The condenser or evaporator is dirty and clogged;
- (4) The air inlet and outlet of the indoor unit or outdoor unit are not smooth;
- (5) The system pipeline is blocked and the valve is not opened;
- (6) Too much refrigerant leads to excessive system pressure;
- (7) The main board is damaged;
- (8) The compressor is damaged.

### **3. Troubleshooting**

Troubleshoot according to the flow chart.

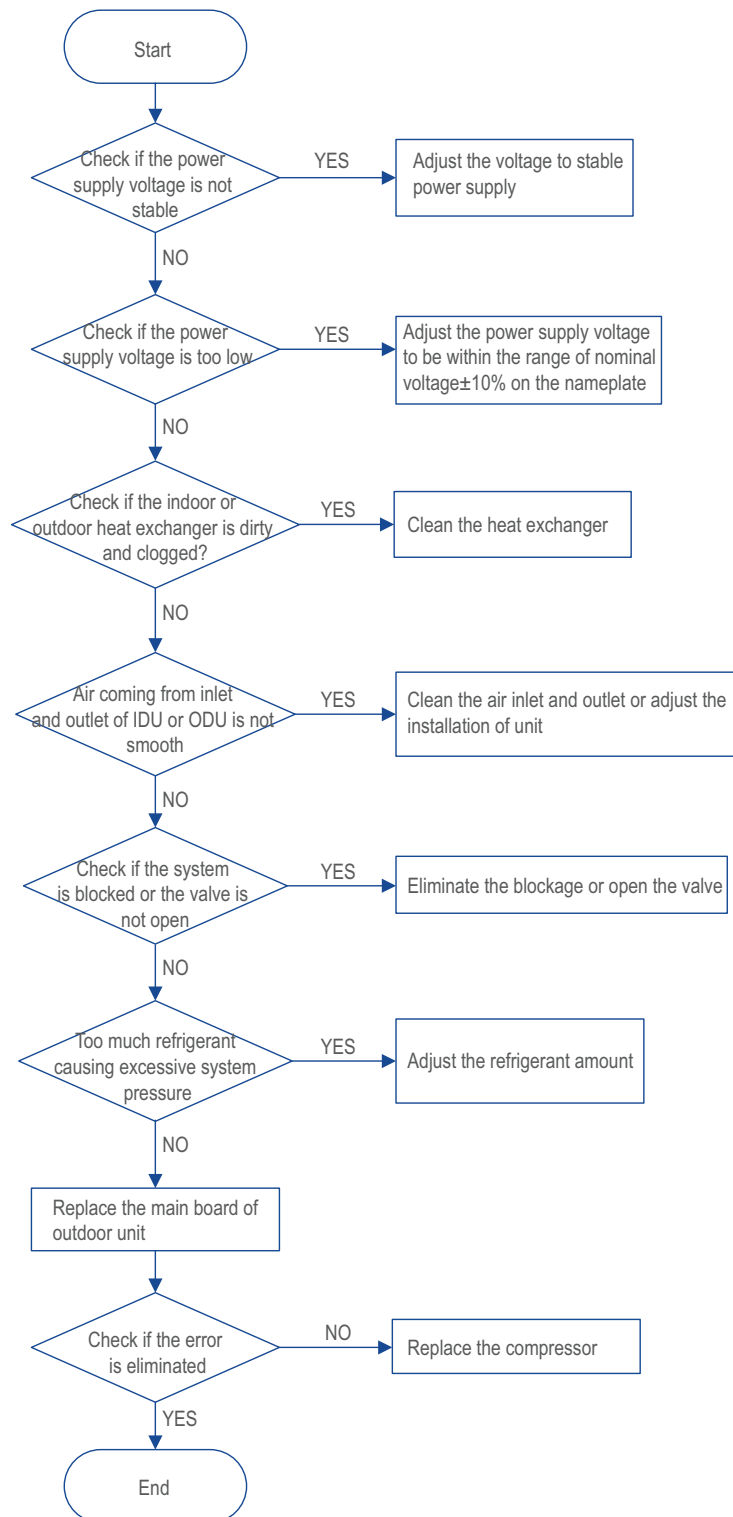

## **H3: Overload Protection of Compressor**

### **1. Error description**

When the main board detects that the compressor overload protection switch is disconnected, it will report the compressor overload protection.

Principle: The overload protection switch is in a short-circuit state at both ends under normal circumstances, and it will be disconnected when the temperature at the top of the compressor is too high.

### **2. Possible causes**

- (1) The connection between the overload connection wire and the main board or the overload protector is unreliable, and the terminal is loose;
- (2) The overload protector is damaged, under normal circumstances, the impedance at both ends of the test overload protector should be less than  $1\Omega$ ;
- (3) The overload connection wire is damaged, resulting in the short circuit of wire;
- (4) Refrigerant leakage or system blockage;
- (5) The main board is damaged.

### **3. Troubleshooting**

Troubleshoot according to the flow chart.

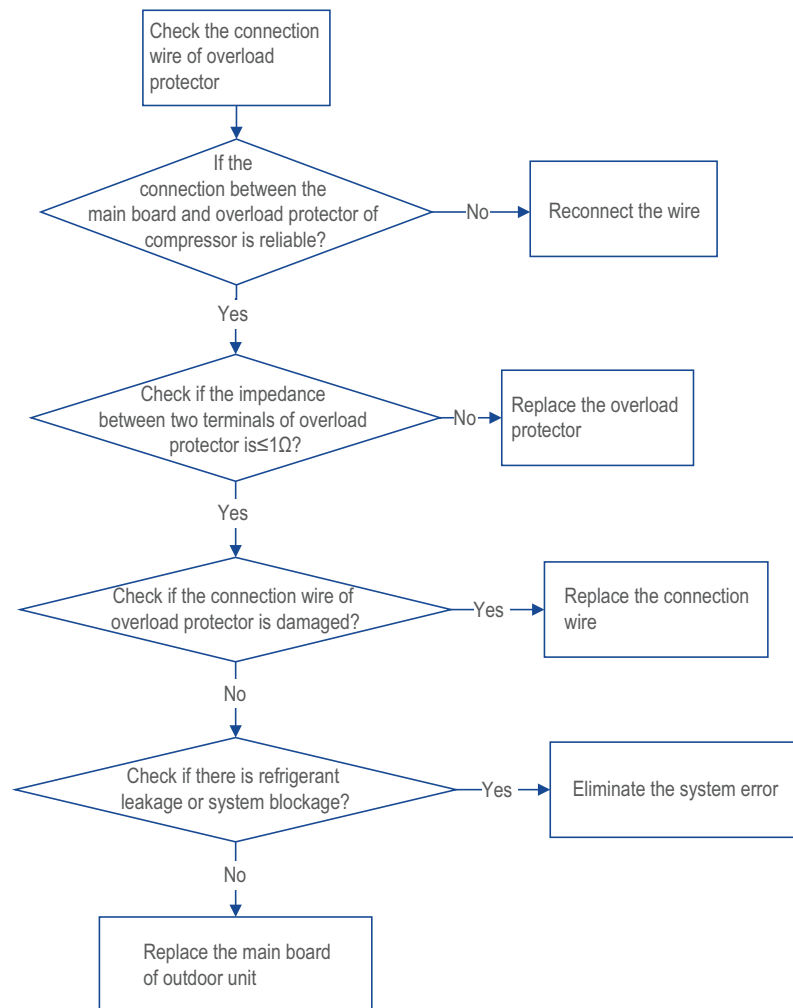

## **EA: Refrigerant Leak Alarm**

### **1. Error description**

If the refrigerant sensor detects that the refrigerant concentration exceeds 10%LFL, the refrigerant leak alarm will be triggered, and the indoor unit will display the EA code, the buzzer will beep, the fan will run, and the outdoor unit will stop.

If the refrigerant concentration is lower than 10%LFL for 5min30s, the refrigerant leak alarm will be withdrawn and the unit will resume normal operation.

### **2. Possible causes**

- (1) Evaporator pipeline is damaged or the refrigerant leaks;
- (2) There is a possibility that flammable gases, explosive gases, smoke, ethanol gases (such as perfumes, etc.), and smoke-producing items (such as cigarettes, etc.) may trigger refrigerant leak alarms;
- (3) Electromagnetic interference, such as high-power electrical equipment may trigger sensor alarms.

### **3. Troubleshooting**

- (1) Open the window for ventilation to reduce the indoor refrigerant concentration below the alarm threshold;
- (2) Detect whether there is refrigerant leakage in the unit, detect the pressure of the refrigerant in the unit, and see whether the amount of refrigerant is within the normal range;
- (3) Check the indoor air quality, if there is a gas that is easy to trigger the refrigerant leak alarm, please remove the gas;
- (4) Check the electromagnetic interference situation on the indoor side, if there is high-power equipment interfering with the refrigerant sensor, keep the high-power equipment far away from the air conditioner or turn off the high-power equipment;
- (5) Replace the refrigerant sensor.

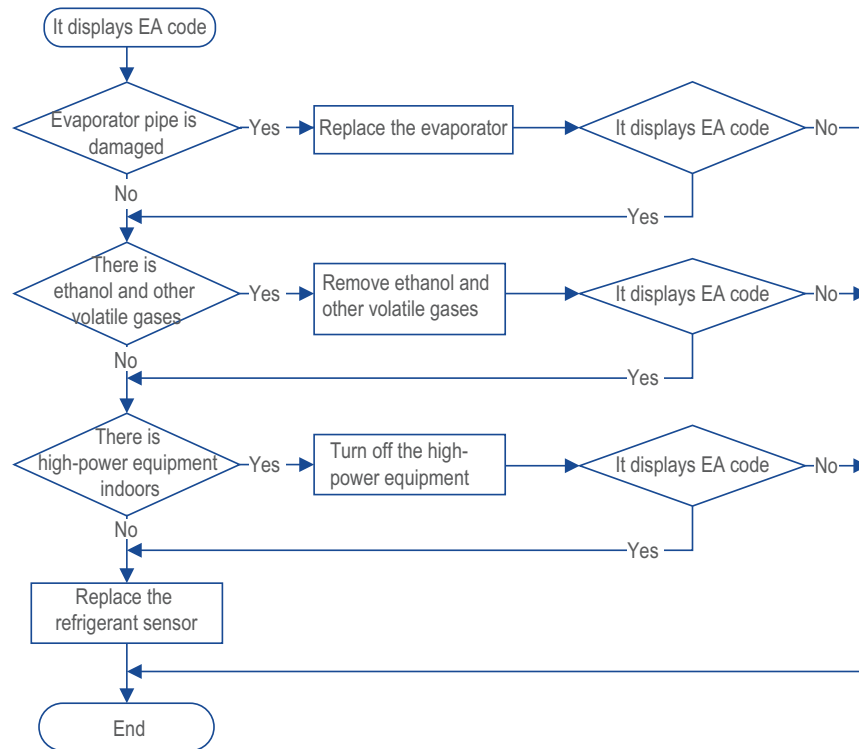

## **FE: Refrigerant Sensor Error**

### **1. Error description**

If there is internal error of the refrigerant sensor module or the communication between the refrigerant sensor and the main board is abnormal, the refrigerant sensor alarm will be triggered, and the indoor unit will display the FE code, buzzer will beep, the fan will operate, and the outdoor unit will stop (only applicable to some models).

### **2. Possible causes**

- (1) The connection wire between refrigerant sensor and the main control is loose or in poor contact, and it can not communicate normally;
- (2) The service life of the refrigerant sensor has expired or failed, and it cannot communicate with the main control normally;
- (3) The communication circuit of the main control and refrigerant sensor is abnormal and it cannot communicate with the sensor normally.

### **3. Troubleshooting**

- (1) Replace the connection wire between the refrigerant sensor and main control;
- (2) Replace the refrigerant sensor;
- (3) Replace the main board of the indoor unit.

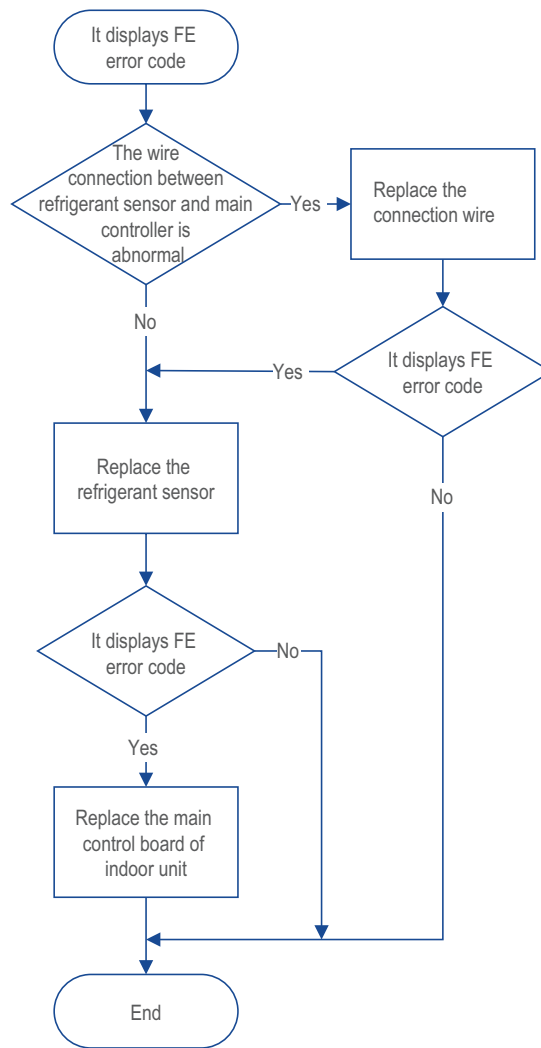

## **E i: High Pressure Protection of System**

### **1. Error description**

When the main board detects that the system high pressure protection switch is disconnected, it will report system high pressure protection.

Principle: The system high pressure protection switch is in a short-circuit state at both ends under normal circumstances, and it will be disconnected when the system pressure exceeds the limit value.

### **2. Possible causes**

- (1) The connection between the connecting wire and the main board or the high pressure protection switch is unreliable, or the terminal is loose;
- (2) The high pressure protection switch is damaged, under normal circumstances, the impedance of both ends of the high pressure protection switch should be less than  $1\Omega$ ;
- (3) The system pressure is too high due to abnormalities such as dirt blockage of the condenser or evaporator, unsmooth air inlet and outlet, excessive refrigerant, and blockage of system pipelines;
- (4) The main board is damaged.

### **3. Troubleshooting**

Troubleshoot according to the flow chart.

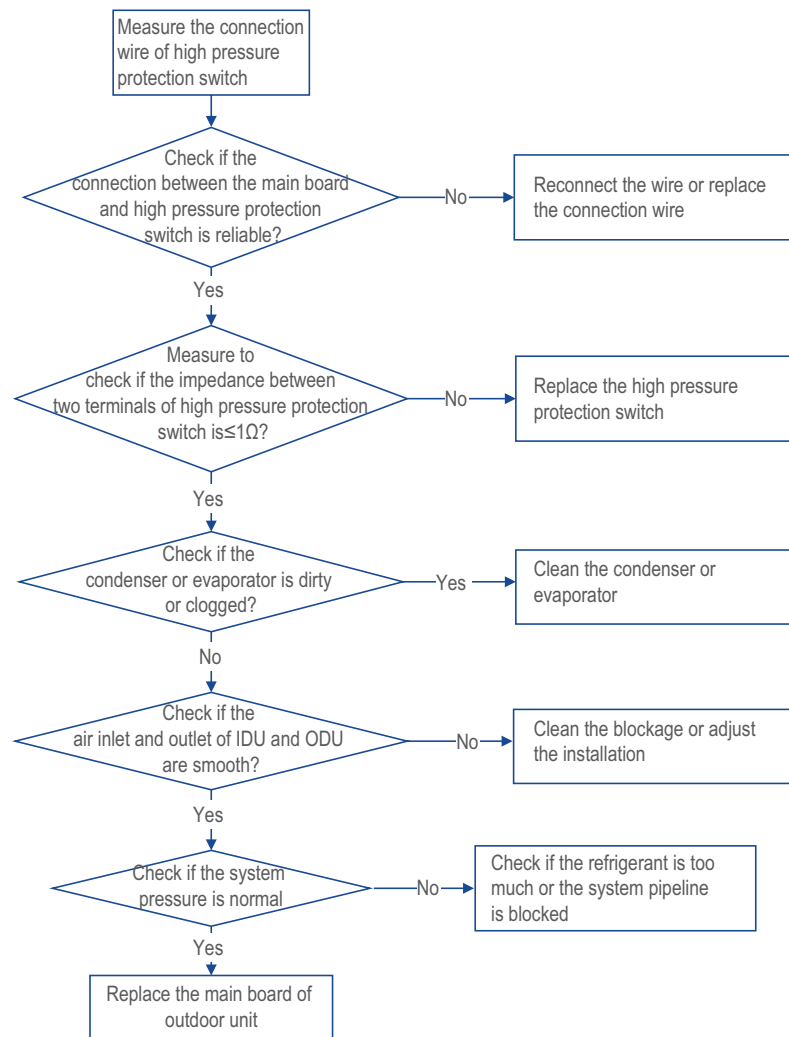

## **E3: Low Pressure Protection/System Low Pressure Protection/Compressor Low Pressure Protection**

### **1. Error description**

- (1) Cooling/dehumidification: Compressor and outdoor fan stop running;
- (2) Heating: All loads stop running;
- (3) Principle: The low pressure protection switch is normal closed. When the compressor pressure is too low, the switch will open. The mainboard detects the open signal and reports low-pressure protection.

### **2. Possible causes**

- (1) Refrigerant leakage;
- (2) The low pressure protector is damaged or poorly connected;
- (3) The main board is damaged.

### **3. Troubleshooting**

Check whether the connecting wire is damaged and whether it is reliably connected; check whether the low pressure protector is damaged; check whether there is a possibility of refrigerant leakage.

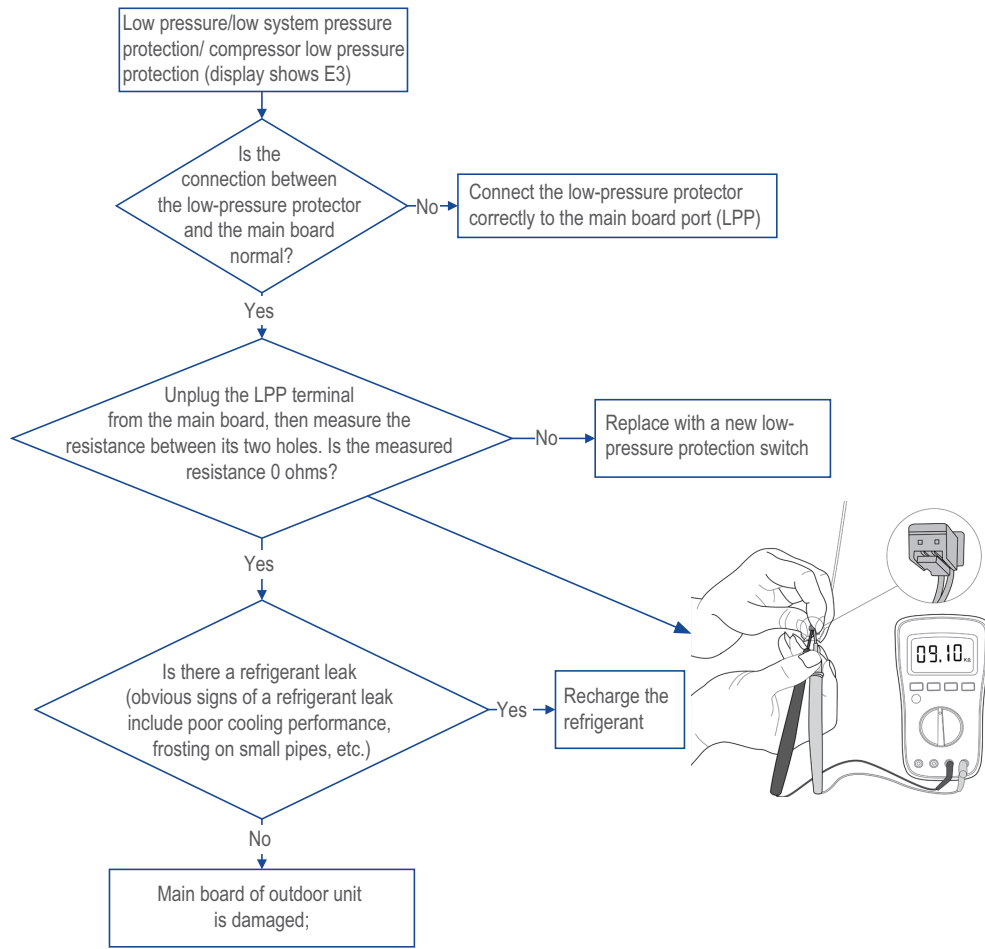

## **E7: Mode Conflict**

### **1. Error description**

If an outdoor unit is connected to multiple indoor units, and the operation modes of each indoor unit do not match, an E7 mode conflict error will be reported.

### **2. Possible causes**

In multiple indoor units, some indoor units have the heating mode on, and some of the indoor units have the cooling mode, dry mode or air supply mode on, resulting in a conflict between the modes.

### **3. Troubleshooting**

Troubleshoot according to the flow chart.

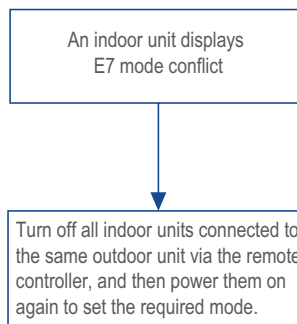

## EE: Read EEPROM Error

### 1. Error description

- (1) Cooling/dehumidification: Compressor and outdoor fan stop running;
- (2) Heating: All loads stop running;
- (3) Principle: The memory chip or memory chip circuit fails, and it's unable to read the data from the memory chip.

### 2. Possible causes

- (1) The main board is damaged;
- (2) It is caused by misuse.

### 3. Troubleshooting

Disconnect the power supply and restart and wait for 5 ~ 8 minutes before turning on the unit to view, if it is still not recovered, replace the main board of the outdoor unit.

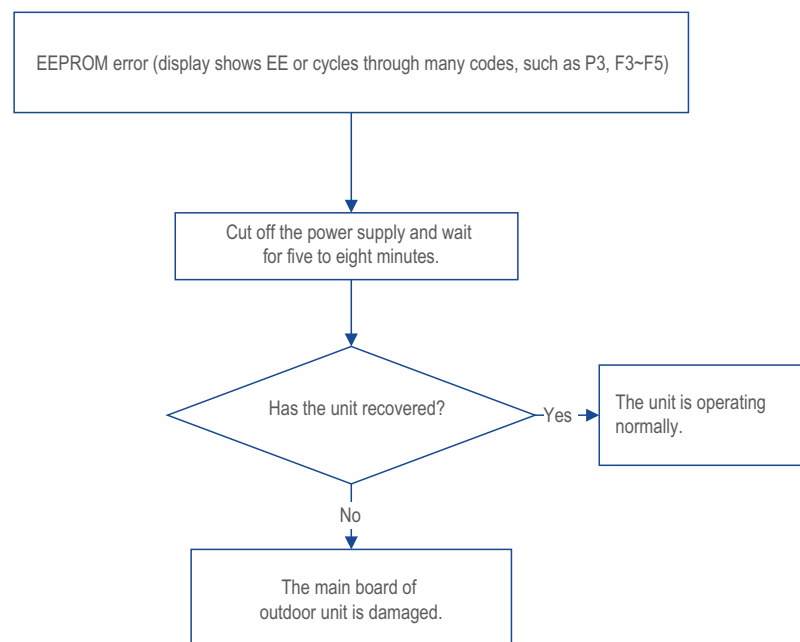

## Lc: Startup Failure

### 1. Error description

If the compressor cannot be started successfully within a certain period of time, it will report the Lc compressor startup failure.

### 2. Possible causes

- (1) The power supply voltage is abnormal;
- (2) The system pipeline is blocked and the valve is not opened;
- (3) Too much refrigerant leads to excessive system pressure;
- (4) The main board is damaged;
- (5) The compressor is damaged.

### 3. Troubleshooting

Troubleshoot according to the flow chart.

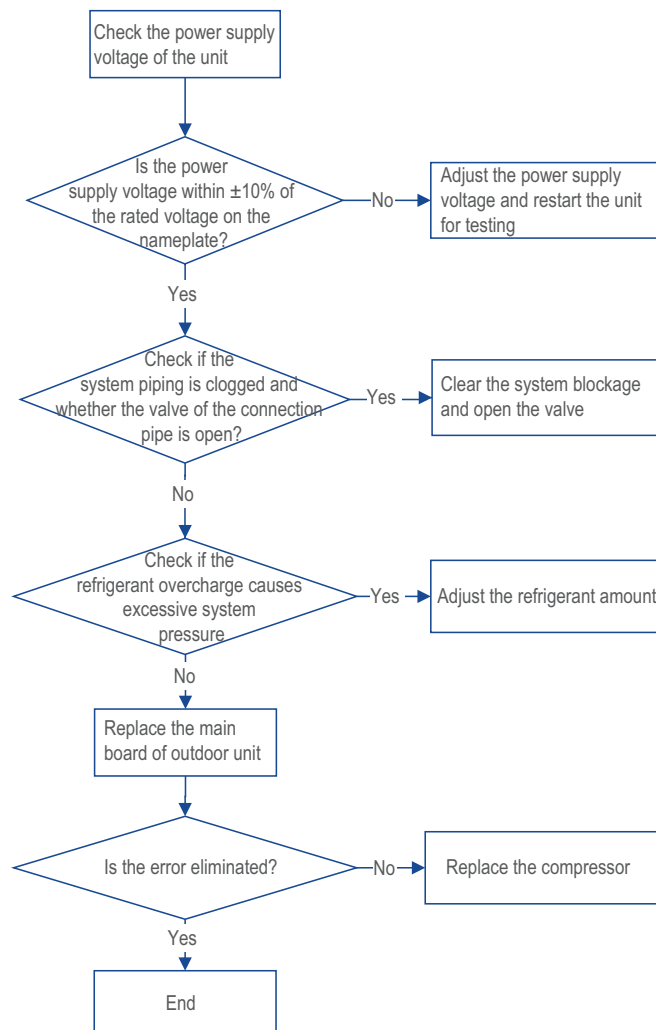

## Ld: Phase-loss Protection of Compressor

### 1. Error description

During the operation of the air conditioner, the three-phase current of the compressor U, V and W is detected, and when a certain phase current loss is detected, the Ld compressor phase-loss protection will be reported.

### 2. Possible causes

- (1) The connection between the connecting wire and the main board or compressor is unreliable, and the terminal is loose;
- (2) The main board is damaged;
- (3) The compressor is damaged.

### 3. Troubleshooting

Troubleshoot according to the flow chart.

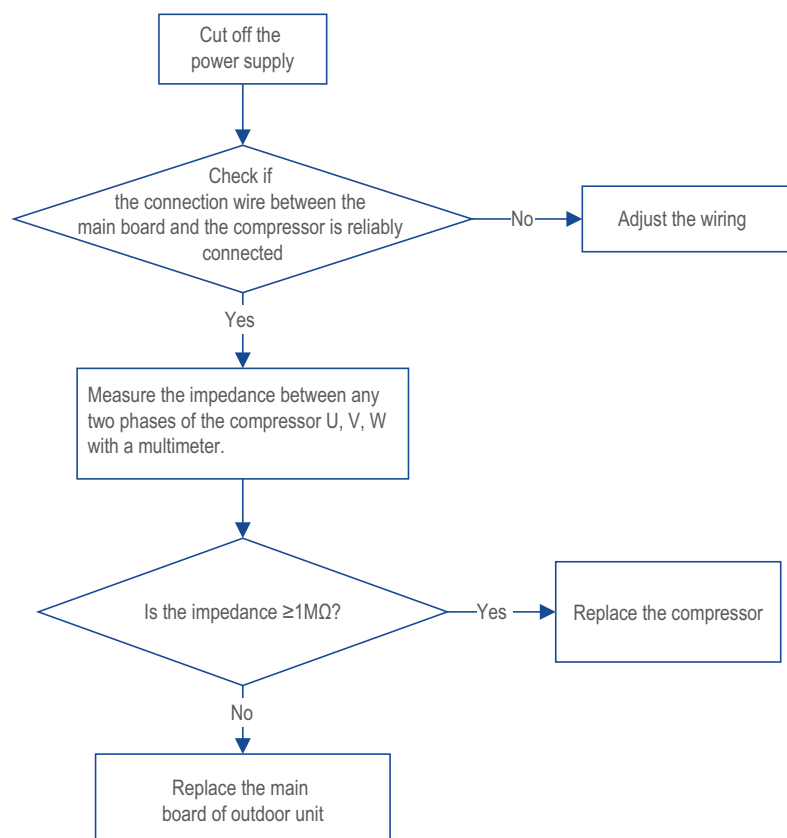

## **oE: Undefined Outdoor Unit Error**

### **1. Error description**

When the main board detects an error that causes the outdoor unit to shut down, this error code is displayed, usually accompanied by other error codes that cause the shutdown.

### **2. Possible causes**

- (1) Compressor startup failure;
- (2) Compressor overload protection;
- (3) The indoor unit requires to shut down.

### **3. Troubleshooting**

This error indicator is a general indicator, usually accompanied by other specific shutdown error codes, and needs to be analyzed and processed in combination with other shutdown error codes.

## P7: Circuit Error of Module Temperature Sensor

### 1. Error description

- (1) Cooling/dehumidification: Compressor and outdoor fan stop running;
- (2) Heating: All loads stop running;
- (3) Principle: The main program detects that the temperature of the compressor IPM Module is abnormal, usually the compressor IPM Module or the detection circuit is damaged.

### 2. Possible causes

- (1) Compressor IPM Module is damaged;
- (2) The circuit of the main board of outdoor unit is damaged.

### 3. Troubleshooting

Disconnect the power supply and wait for 5 to 8 minutes before restarting the unit.

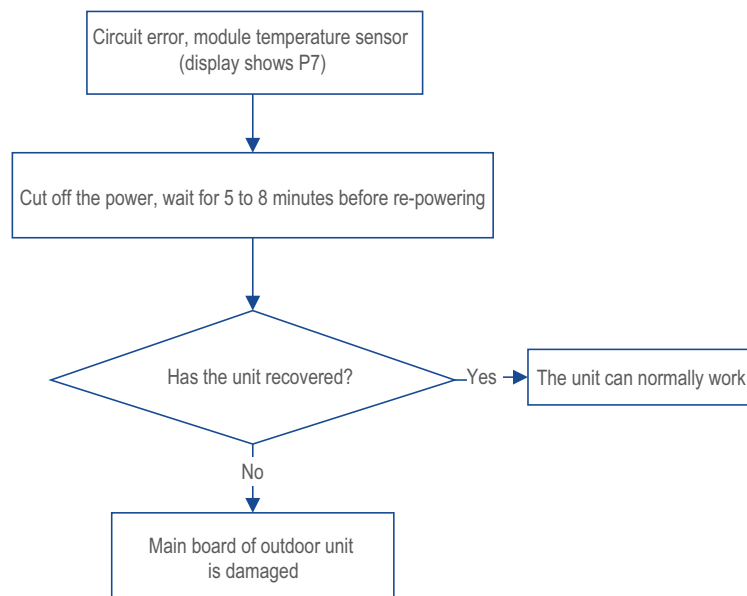

## ***P8: High-temperature Protection of Module***

### **1. Error description**

- (1) Cooling/dehumidification: Compressor and outdoor fan stop running;
- (2) Heating: All loads stop running;
- (3) Principle: The main program detects that the module temperature is too high and exceeds the protection value.

### **2. Possible causes**

- (1) The outdoor fan is blocked by foreign objects, resulting in poor heat dissipation;
- (2) The outdoor condenser is blocked by foreign objects, resulting in poor heat dissipation;
- (3) The screws between the IPM module and the radiator on the main board are not tightened, resulting in poor heat dissipation;
- (4) There is not enough thermal paste on the IPM;
- (5) The main board of outdoor unit is damaged.

### **3. Troubleshooting**

- (1) Check whether the outdoor fan is blocked by foreign objects;
- (2) Check whether the outdoor condenser is blocked by foreign objects;
- (3) Check whether the screws between the IPM module and the radiator are tightened;
- (4) Check whether there is enough thermal paste on the IPM module.

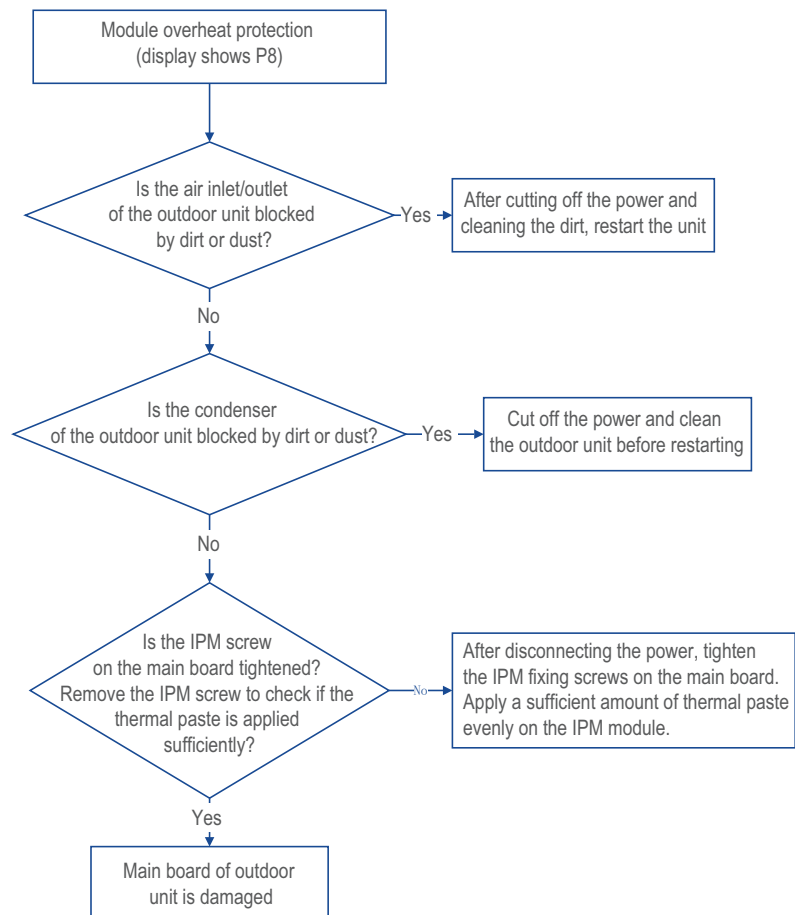

## PU: Capacitor Charging Error

### 1. Error description

After energizing the unit, the voltage of the DC bus of the main board of outdoor unit has not reached 100V.

### 2. Possible causes

- (1) The AC power supply voltage is too low;
- (2) The reactor wiring is incorrect;
- (3) The main board of outdoor unit is damaged.

### 3. Troubleshooting

Troubleshoot according to the flow chart.

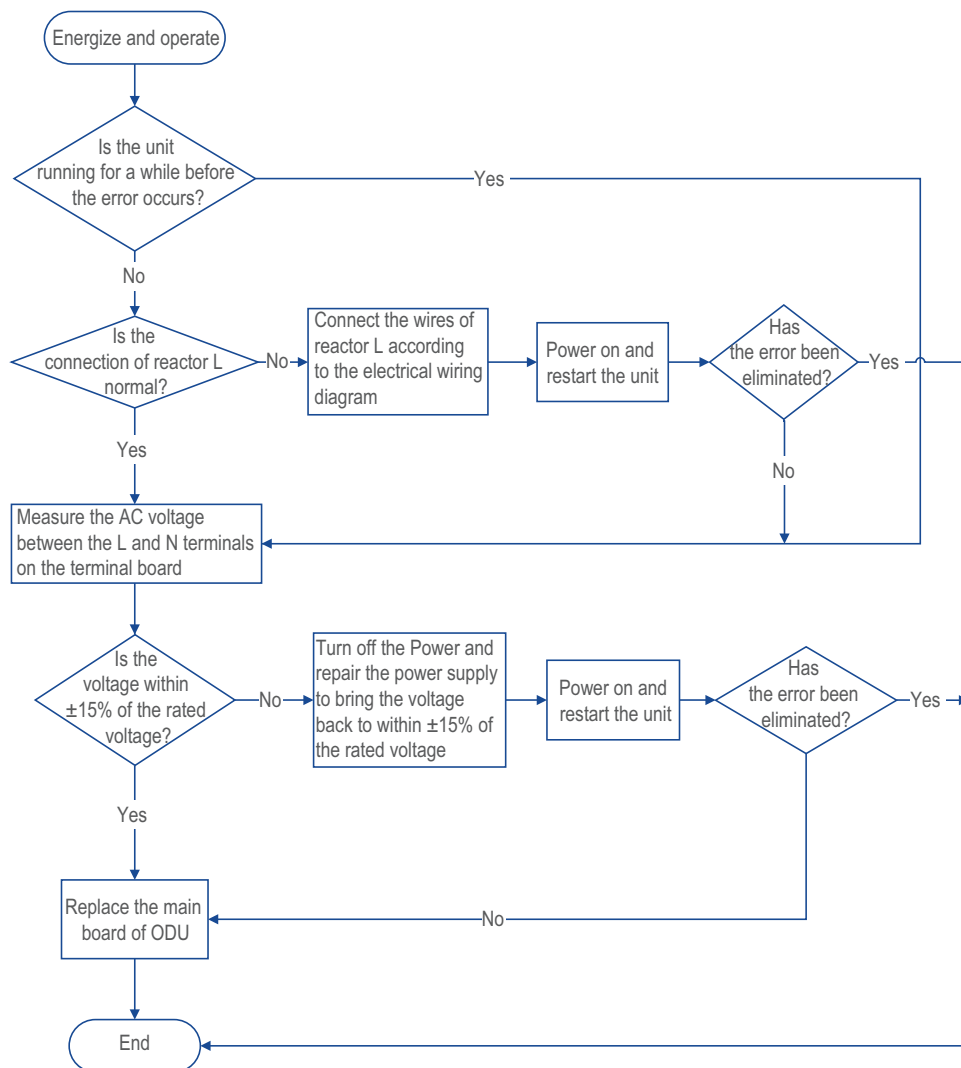

## ***rF*: RF Module Error**

### **1. Error description**

- (1) Cooling: The compressor and the outdoor fan stop running;
- (2) Heating: The compressor and the outdoor fan stop running immediately, and the indoor fan stops running after 1 minute.

### **2. Possible causes**

- (1) The connection between the RF module and the main board is abnormal;
- (2) The RF module is faulted.

### **3. Troubleshooting**

- (1) Adjust the connection between the RF module and the main board;
- (2) Replace the RF module.

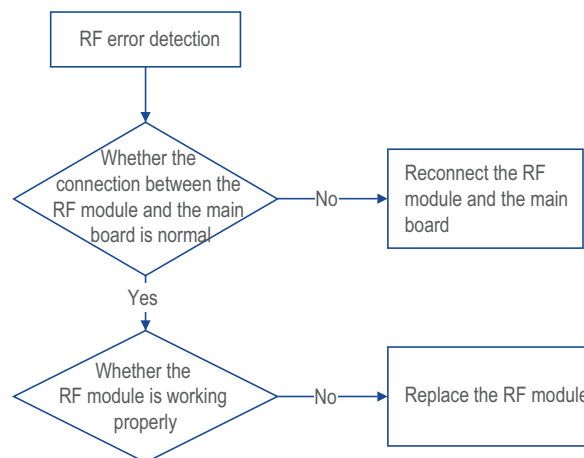

## **FC: Micro-switch Error**

### **1. Error description**

- (1) Cooling/dehumidification: All loads stop running;
- (2) Heating: All loads stop running.

### **2. Possible causes**

- (1) The connection between the sliding door motor and the main board is abnormal;
- (2) The sliding door does not run smoothly;
- (3) The pushing rods of left and right sliding door do not run consistently.

### **3. Troubleshooting**

- (1) Check the connection between the sliding door motor and the main board;
- (2) Check whether the air louver and pushing rod are installed properly;
- (3) Disconnect the power supply of the unit, push the air louver and pushing rod to the closed state, connect the power supply and restart the unit, and observe whether the operation of the left and right air louvers and pushing rods are blocked;
- (4) Disconnect the power supply of the unit, push the air louver and pushing rod to the closed state, restart the power supply, and observe whether the push distance of the air louver and pushing rods are equal and balanced.

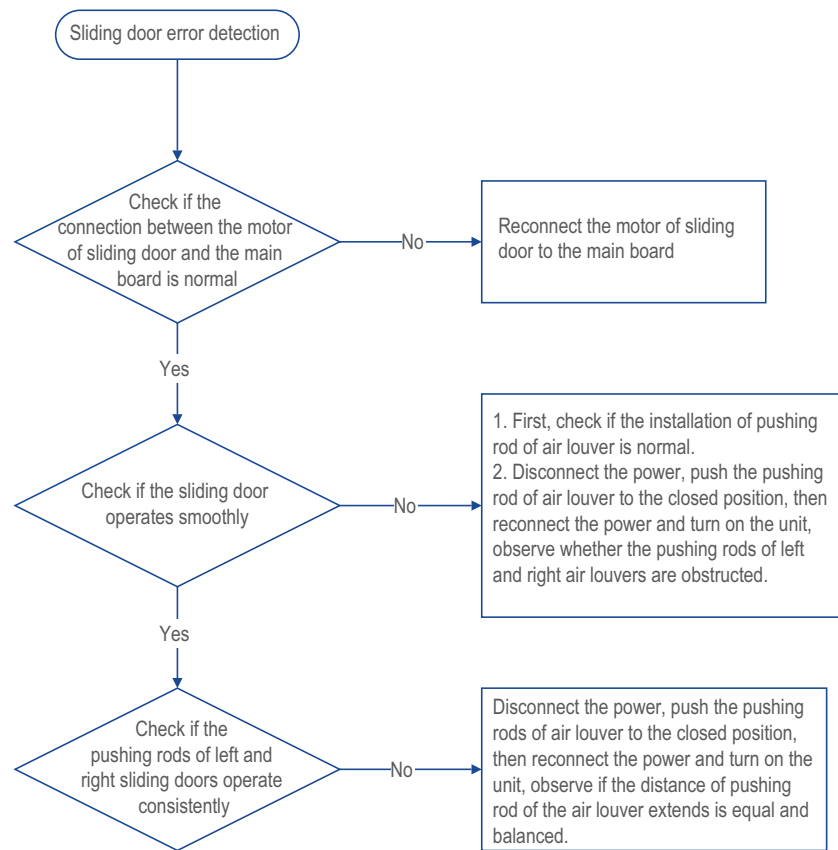

## JF: Communication Error Between Indoor Unit and Detective Board

### 1. Error description

When the main board of indoor unit detects abnormal communication with the WIFI module, this error code will appear, but the error will not be displayed actively.

### 2. Possible causes

- (1) The communication circuit of the main board of indoor unit or WIFI module is damaged;
- (2) The inter-board wire connection may be damaged.

### 3. Troubleshooting

Replace the WIFI module/inter-board wire connection/main board.

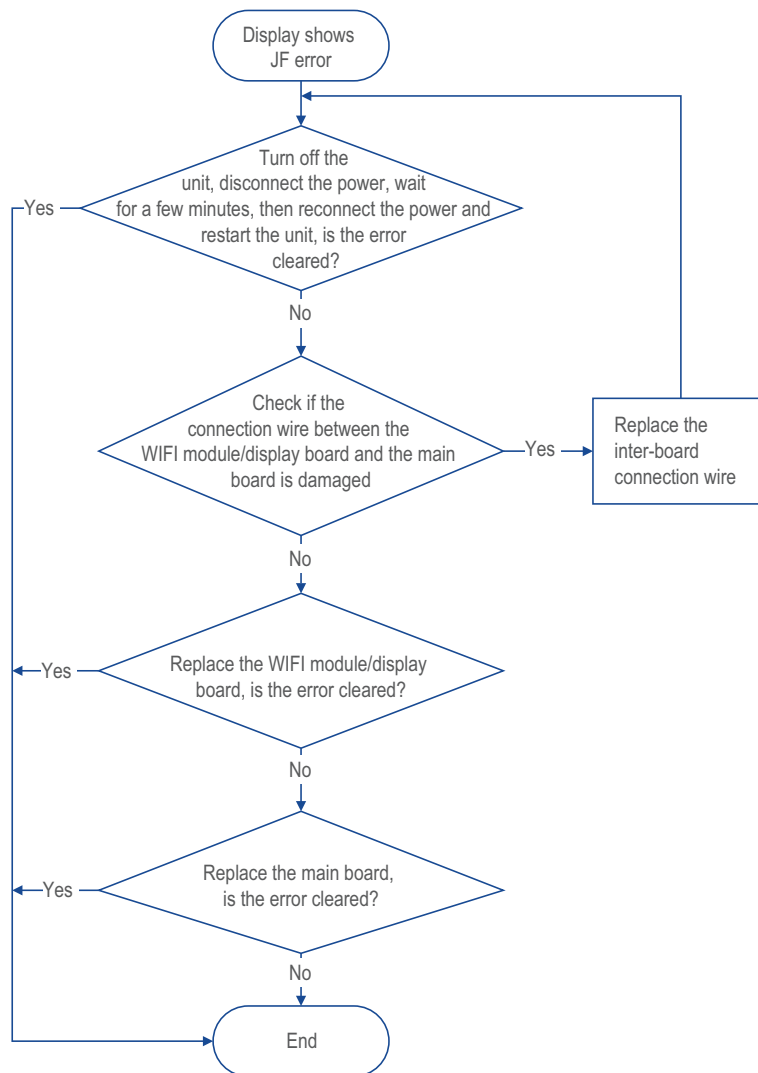

## **Networking Error**

### **1. Error description**

The APP cannot control the indoor unit normally/cannot connect to the network.

### **2. Possible causes**

- (1) The APP version is not the latest;
- (2) The APP is not compatible with the mobile phone system;
- (3) The home network frequency band is not supported (not 2.4GHz);
- (4) The communication circuit between the main board and the WIFI module is abnormal.

### **3. Troubleshooting**

- (1) Update the APP version;
- (2) Use other mobile phone brands or systems to connect to the network;
- (3) Check whether the home network meets the requirements;
- (4) Replace the main board or WIFI module.

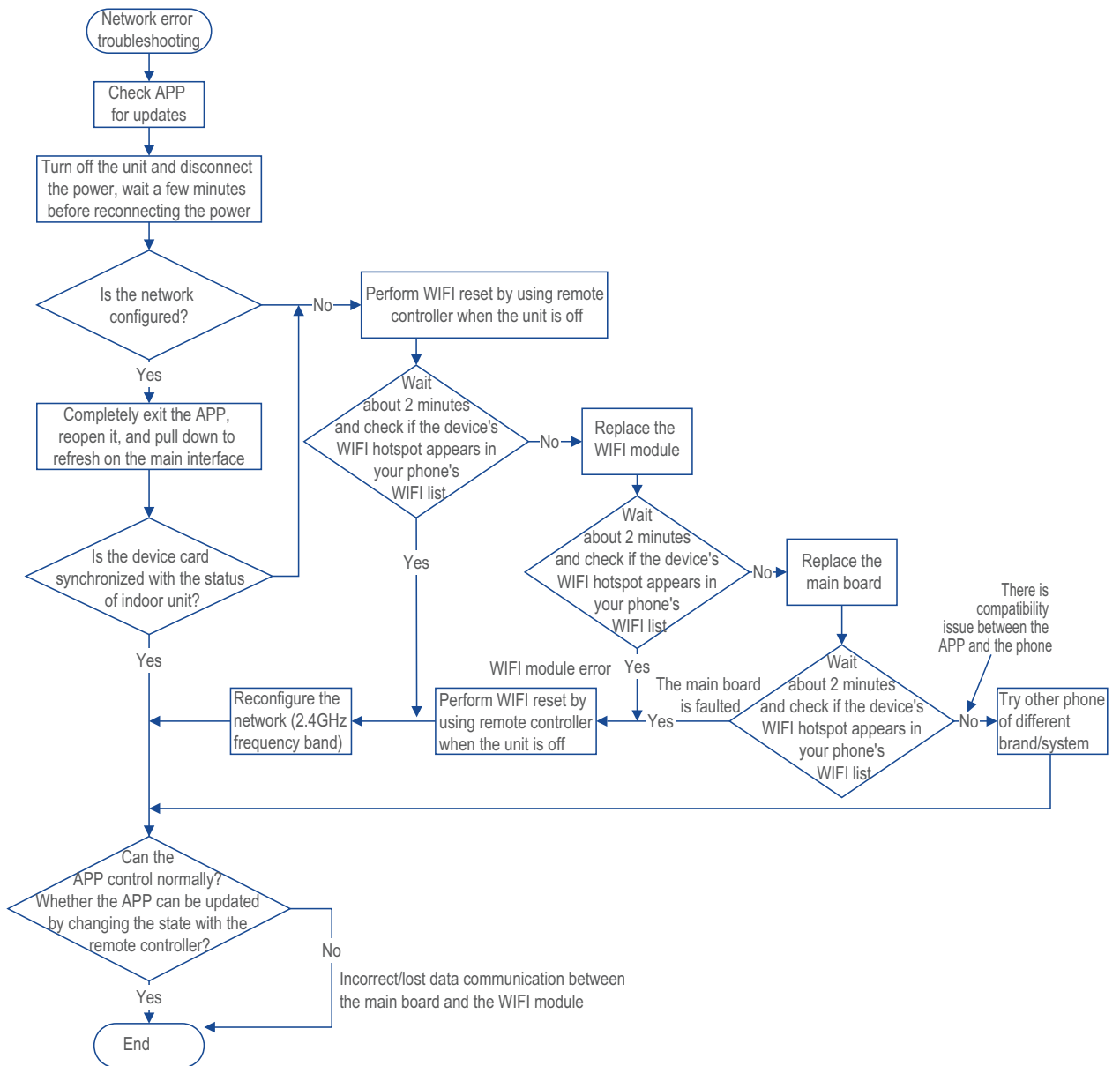

## 9.3 Checkup

### 1. Check the thermal resistor resistance

#### (1) Tool preparation

Multimeter.

#### (2) Find the model of thermal resistor

Check the label on the outer case of the thermal resistor to find the model number. Refer to the resistance table of thermal resistor in the appendix to find the resistance range corresponding to the model.

#### (3) Disconnection

Disconnect the thermal resistor from the connector on the PCB board. This ensures that you are measuring the resistance of the thermal resistor itself, not the entire circuit.

#### (4) Measure resistance

Use the resistance mode on the multimeter (usually marked as  $\Omega$ ). Place the two probes of the multimeter on the two pins of the thermal resistor to measure its resistance.

#### (5) Compare resistance

Compare the measured resistance with the resistance mode for the corresponding model in Appendix 4. If the measured resistance is outside the specified range, it indicates that the thermal resistor may be damaged and needs to be replaced.

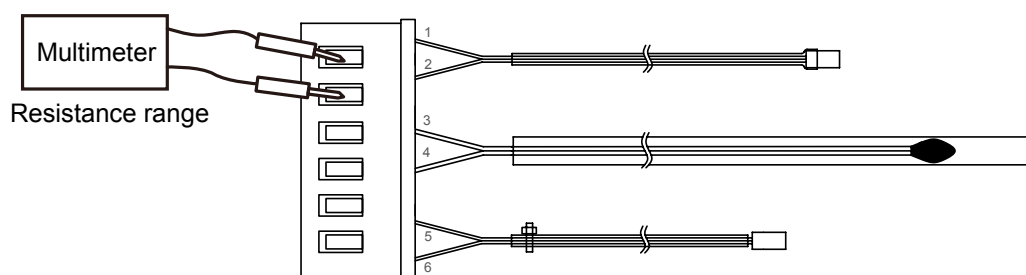
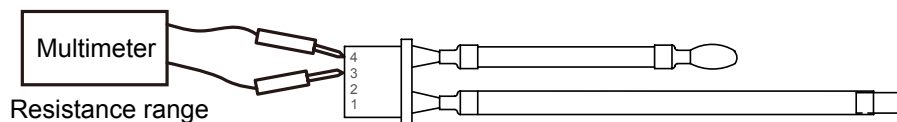

## 2. Check the electronic expansion valve

### 1. Check the connection

Check whether the connector of the electronic expansion valve (EV) is properly connected to the PCB board.

- Make sure that the connector is firmly plugged in and there is no looseness or poor contact.

### 2. Check the action sound

Turn off the power, then turn it back on, and check whether the electronic expansion valve makes a latching sound.

- This sound indicates that the electronic expansion valve is responding to the control signal.

### 3. Check the coil

If the electronic expansion valve does not make a latching sound in step 2, disconnect the connector and use a multimeter to check the conductivity of the connector.

- Use the resistance mode of the multimeter (usually marked as  $\Omega$ ), use the probe to touch the corresponding pins of the connector to check whether there is continuity. Check the conductivity between the connector pins. The specific pin combinations are as follows:

Pin 5 - 1

Pin 5 - 2

Pin 5 - 3

Pin 5 - 4

If there is no conduction between these pins (i.e. the measured resistance value is infinite), the coil of the electronic expansion valve may be damaged and the electronic expansion valve coil needs to be replaced.

### 4. Check the PCB board

If the conductivity between the pins is confirmed in step 3, but the electronic expansion valve still does not make a latching sound, it means that the PCB board of outdoor unit (main PCB board) may be faulty.

- Further inspection or replacement of the PCB board of outdoor unit is required.

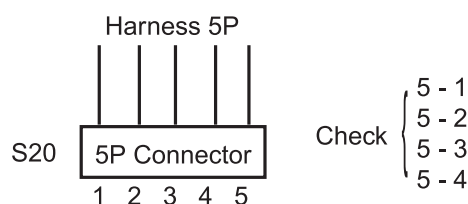

### 3. Check the compressor

#### 1. Disconnect the power supply

Disconnect the compressor power cord from the PCB board of outdoor unit.

- Make sure the power supply is completely disconnected to avoid the risk of electric shock.

#### 2. Measure the winding resistance

Use the resistance mode (usually marked as  $\Omega$ ) of the multimeter to measure the resistance between the compressor windings.

- The compressor usually has three terminals, namely U, V, W (or similar identification). The following combinations of resistance values need to be measured:

U - V

U - W

V - W

#### 3. Check the resistance consistency

Make sure the resistance between any two terminals is roughly equal.

- Under normal circumstances, these three resistance values should be very close. If one resistance value is significantly different, it may indicate a problem with the winding.

#### 4. Check the insulation to ground

Measure the resistance between each terminal and the outer case of compressor.

- Use one probe of the multimeter to touch the outer case of compressor and the other probe to the U, V, and W terminals respectively.
- If the measured resistance value is very low (close to  $0\Omega$ ), there is a short circuit between the winding and the outer case and the compressor needs to be replaced.

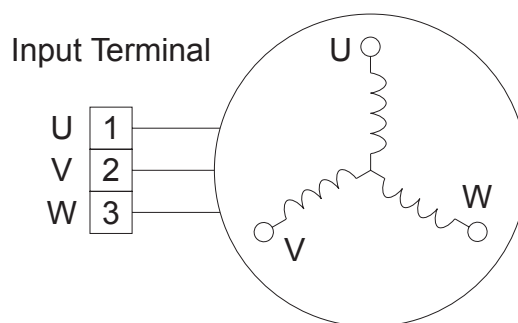

#### **4. Check the 4-way valve coil**

Measure the resistance between the two leads of the coil. If the resistance is between 500~2500Ω, the coil is normal. If the resistance is infinite, the coil is abnormal.

- The resistance of DC24V coil is about 550Ω;
- The resistance of AC110-120V coil is about 550Ω;
- The resistance of AC220-240V coil is about 2000~2500Ω.

## 9.4 Troubleshooting for Normal Malfunction

### 1. *Air Conditioner Can't be Started Up*

Possible Causes	Troubleshooting
No power supply, or poor connection for power plug	<ul style="list-style-type: none"> <li>• Confirm whether it's due to power failure.</li> <li>— If yes, wait for power recovery.</li> <li>— If not, check power supply circuit and make sure the power plug is connected well.</li> </ul>
Wrong wire connection between indoor unit and outdoor unit, or poor connection for wiring terminals	<ul style="list-style-type: none"> <li>• Check the circuit according to circuit diagram and connect wires correctly.</li> <li>• Make sure all wiring terminals are connected firmly</li> </ul>
Electric leakage for air conditioner	<ul style="list-style-type: none"> <li>• Make sure the air conditioner is grounded reliably.</li> <li>• Make sure wires of air conditioner is connected correctly.</li> <li>• Check the wiring inside air conditioner. Check whether the insulation layer of power cord is damaged; if yes, place the power cord.</li> </ul>
Model selection for air switch is improper	<ul style="list-style-type: none"> <li>• Select proper air switch</li> </ul>
Malfunction of remote controller	<ul style="list-style-type: none"> <li>• Replace batteries for remote controller</li> <li>• Repair or replace remote controller</li> </ul>

## 2. Poor Cooling (Heating) for Air Conditioner

Possible Causes	Troubleshooting
Set temperature is improper	<ul style="list-style-type: none"> <li>Adjust the set temperature</li> </ul>
Rotation speed of the IDU fan motor is set too low	<ul style="list-style-type: none"> <li>Set the fan speed at high or medium</li> </ul>
Filter of indoor unit is blocked	<ul style="list-style-type: none"> <li>Clean the filter</li> </ul>
Installation position for indoor unit and outdoor unit is improper	<ul style="list-style-type: none"> <li>Adjust the installation position, and install the rainproof and sunproof for outdoor unit</li> </ul>
Refrigerant is leaking	<ul style="list-style-type: none"> <li>Find out the leakage causes and deal with it. Add refrigerant.</li> </ul>
Malfunction of 4-way valve	<ul style="list-style-type: none"> <li>Replace the 4-way valve</li> </ul>
Malfunction of capillary	<ul style="list-style-type: none"> <li>Replace the capillary</li> </ul>
Flow volume of valve is insufficient	<ul style="list-style-type: none"> <li>Open the valve completely</li> </ul>
Malfunction of horizontal louver	<ul style="list-style-type: none"> <li>Refer to point 3 of maintenance method for details</li> </ul>
Malfunction of the IDU fan motor	<ul style="list-style-type: none"> <li>Refer to troubleshooting for H6 for maintenance method in details</li> </ul>
Malfunction of the ODU fan motor	<ul style="list-style-type: none"> <li>Refer to point 4 of maintenance method for details</li> </ul>
Malfunction of compressor	<ul style="list-style-type: none"> <li>Refer to point 5 of maintenance method for details</li> </ul>

### 3. *Horizontal Louver Can't Swing*

Possible Causes	Troubleshooting
Wrong wire connection, or poor connection	<ul style="list-style-type: none"><li>• Connect wires according to wiring diagram to make sure all wiring terminals are connected firmly</li></ul>
Stepping motor is damaged	<ul style="list-style-type: none"><li>• Repair or replace stepping motor</li></ul>
Main board is damaged	<ul style="list-style-type: none"><li>• Replace the main board with the same model</li></ul>

### 4. *ODU Fan Motor Can't Operate*

Possible Causes	Troubleshooting
Wrong wire connection, or poor connection	<ul style="list-style-type: none"><li>• Connect wires according to wiring diagram to make sure all wiring terminals are connected firmly</li></ul>
Capacity of the ODU fan motor is damaged	<ul style="list-style-type: none"><li>• Replace the capacity of fan</li></ul>
Power voltage is a little low or high	<ul style="list-style-type: none"><li>• Suggest to equip with voltage regulator</li></ul>
Motor of outdoor unit is damaged	<ul style="list-style-type: none"><li>• Change compressor oil and refrigerant. If no better, replace the compressor with a new one</li></ul>

## 5. Air Conditioner is Leaking

Possible Causes	Troubleshooting
Drain pipe is blocked	<ul style="list-style-type: none"><li>• Eliminate the foreign objects inside the drain pipe</li></ul>
Drain pipe is broken	<ul style="list-style-type: none"><li>• Replace drain pipe</li></ul>
Wrapping is not tight	<ul style="list-style-type: none"><li>• Wrap it again and bundle it tightly</li></ul>

## 6. Compressor Can't Operate

Possible Causes	Troubleshooting
Wrong wire connection, or poor connection	<ul style="list-style-type: none"><li>• Connect wires according to wiring diagram to make sure all wiring terminals are connected firmly</li></ul>
Capacity of compressor is damaged	<ul style="list-style-type: none"><li>• Replace the compressor capacitor</li></ul>
Power voltage is a little low or high	<ul style="list-style-type: none"><li>• Suggest to equip with voltage regulator</li></ul>
Coil of compressor is burnt out	<ul style="list-style-type: none"><li>• Repair or replace compressor</li></ul>
Cylinder of compressor is blocked	<ul style="list-style-type: none"><li>• Repair or replace compressor</li></ul>

## 7. Abnormal Sound and Vibration

Possible Causes	Troubleshooting
When turn on or turn off the unit, the panel and other parts will expand and there's abnormal sound	<ul style="list-style-type: none"> <li>● Normal phenomenon. Abnormal sound will disappear after a few minutes.</li> </ul>
When turn on or turn off the unit, there's abnormal sound due to flow of refrigerant inside air conditioner	<ul style="list-style-type: none"> <li>● Normal phenomenon. Abnormal sound will disappear after a few minutes.</li> </ul>
Foreign objects inside the indoor unit or there are parts touching together inside the indoor unit	<ul style="list-style-type: none"> <li>● Remove foreign objects. Adjust all parts position of indoor unit, tighten screws and stick damping plaster between connected parts</li> </ul>
Foreign objects inside the outdoor unit or there are parts touching together inside the outdoor unit	<ul style="list-style-type: none"> <li>● Remove foreign objects. Adjust all parts position of outdoor unit, tighten screws and stick damping plaster between connected parts</li> </ul>
Short circuit inside the magnetic coil	<ul style="list-style-type: none"> <li>● Replace magnetic coil</li> </ul>
Abnormal shake of compressor	<ul style="list-style-type: none"> <li>● Adjust the support foot mat of compressor, tighten the bolts</li> </ul>
Abnormal sound inside the compressor	<ul style="list-style-type: none"> <li>● If add too much refrigerant during maintenance, please reduce refrigerant properly. Replace compressor for other circumstances.</li> </ul>

# 10. Removal Procedure

## 10.1 Removal Procedure of Indoor Unit

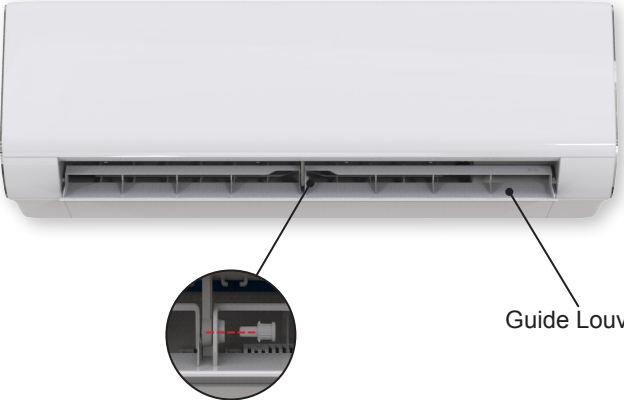
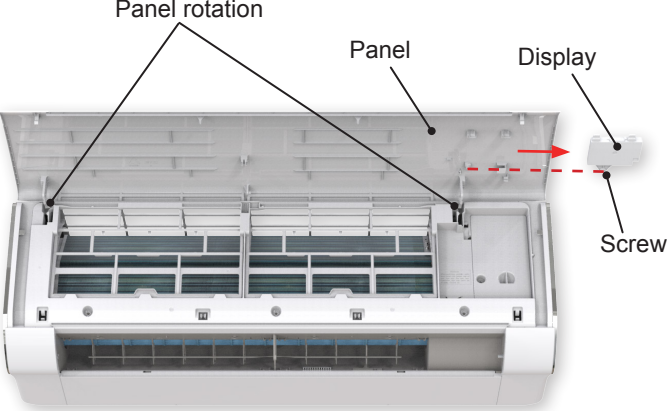
Step	Procedure
<p><b>01</b> <b>Before disassemble</b></p> <p>Turn off the air conditioner and disconnect the power before disassemble the air conditioner.</p>	
<p><b>02</b> <b>Remove guide louver</b></p> <p>Push out the plug pin on guide louver, bend the guide louver with hand and then separate the guide louver from the crank shaft of step motor to remove it.</p>	
<p><b>03</b> <b>Remove panel</b></p> <p>Open the front panel; separate the panel rotation shaft from the groove fixing the front panel and then removes the front panel.</p> <p>Note: The display of some models is fixed on the panel; unscrew the screws fixing the display on the panel before removing the panel.</p>	

Step	Procedure
------	-----------

## 04

### Remove filter

Hold the handle on the filter, pull it forwards and then the filter can be pulled out.

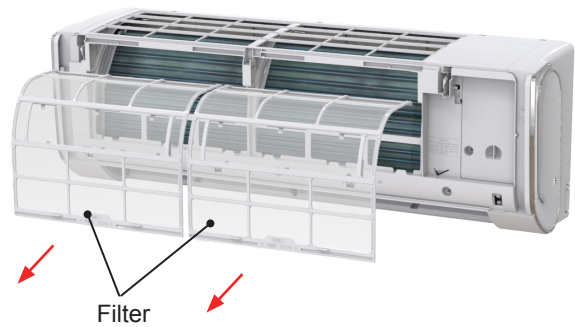

## 05

### Remove electric box cover 2

Remove the screws on the electric box cover 2 to remove the electric box cover 2.

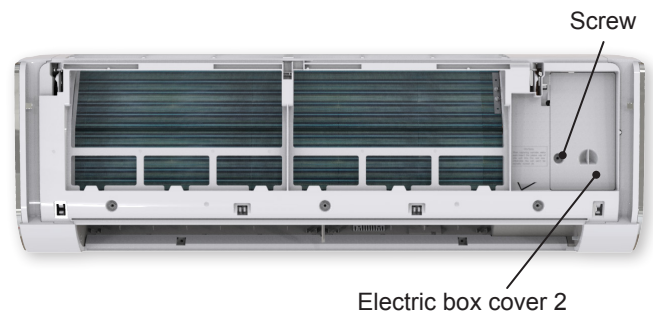

## 06

### Remove front case sub-assy

Remove the screws fixing front case.

Note:

- (1) Open the screw caps before removing the screws around the air outlet.
- (2) The quantity of screws fixing the front case subassy is different for different models.

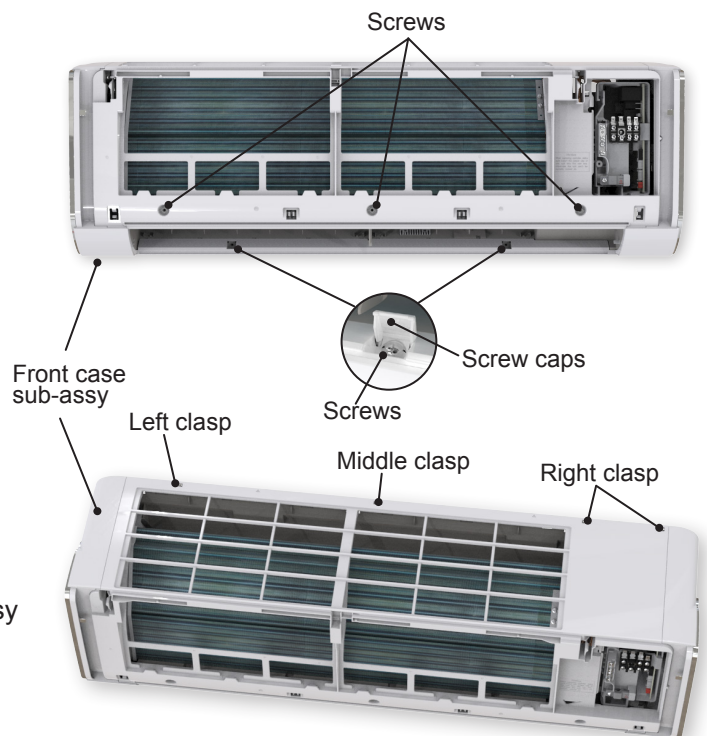

Loosen the clasps at left, middle and right sides of front case. Lift the front case sub-assy upwards to remove it.

Step	Procedure
------	-----------

# 07

## Remove electric box assy

Remove the screw fixing electric box assy.

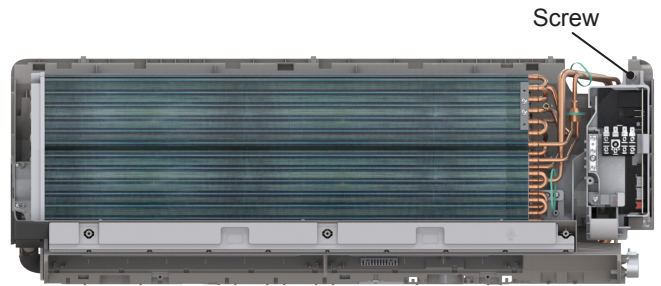

1. Cut off the wire binder and pull out the indoor tube temperature sensor.
2. Screw off one grounding screw.
3. Remove the wiring terminals of motor, cold plasma generator and stepping motor.
4. Remove the electric box assy.
5. Screw off the screws that are locking each.  
(NOTE: Take AC unit for example).

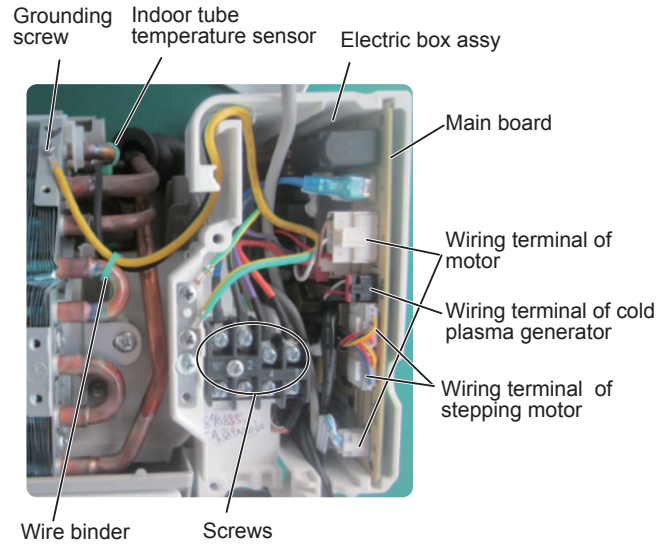

Rotate the electric box assy. Twist off the screws that are locking the wire clip and loosen the power cord. Remove the wiring terminal of power cord. Lift up the main board and take it off.

BCA  
BCB  
BCC

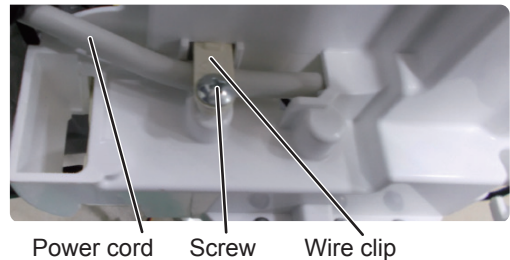

BCD  
BCE

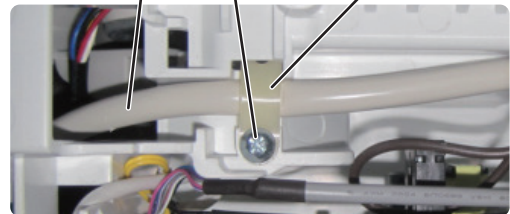

Instruction:Some wiring terminal of this products is with lock catch and other devices. The pulling method is as below:

1. Remove the soft sheath for some terminals at first, hold the circlip and then pull out the terminals,
2. Pull out the holder for some terminals at first (holder is not available for some wiring terminal). hold the connector and then pull the terminal.

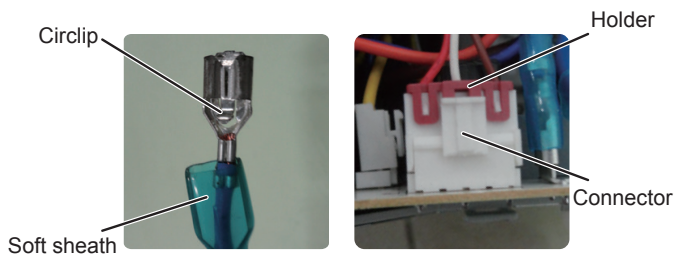

## Step

## Procedure

**08****Remove evaporator assy**

Remove 3 screws fixing evaporator assy.

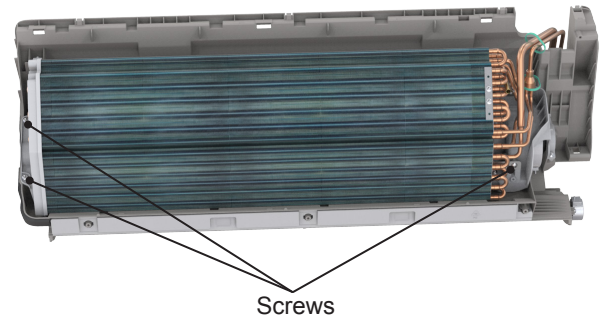

At the back of the unit, Loosen the clasp of the connection pipe clamp and then remove the connection pipe clamp.

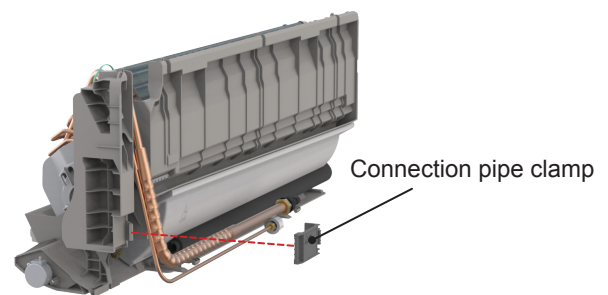

First remove the left side of evaporator from the groove of bottom shell and then remove the right side from the clasp on the bottom shell.

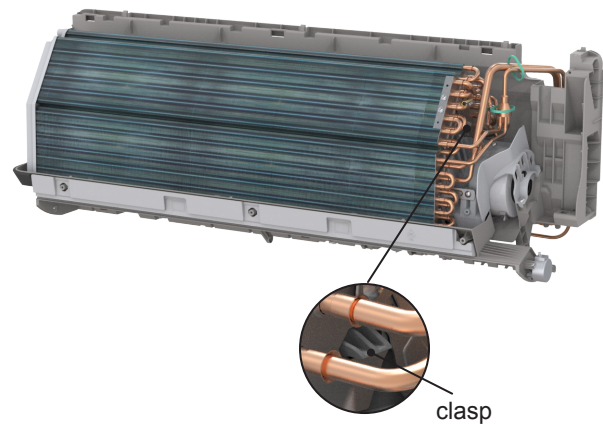

Adjust the position of connection pipe on evaporator slightly and then lift the evaporator upwards to remove it.

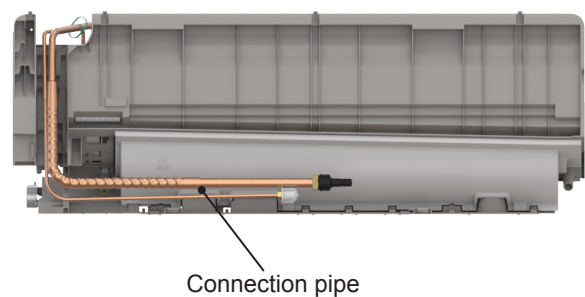

## Step

## Procedure

**09****Remove motor and cross flow fan**

Remove 3 screws fixing motor clamp and then remove the motor clamp..

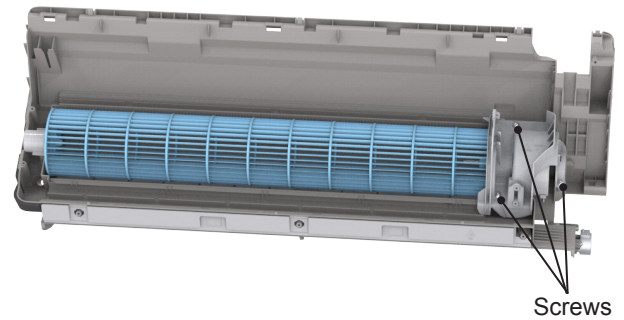

Loose the screws (2-3 circles) used for fixing the cross flow fan, pull right to pull out the motor.

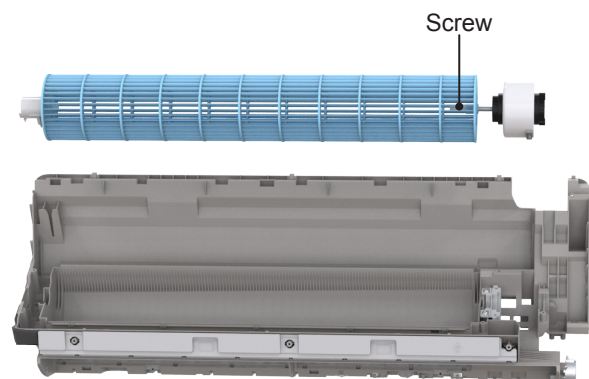
**10****Remove swing motor**

Screw off the screws that are locking the swing motor and take the motor off.

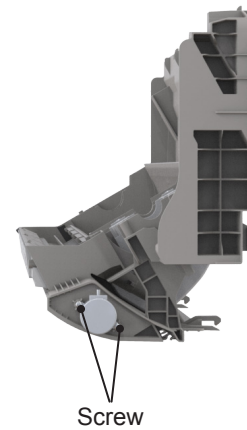

## 10.2 Removal Procedure of Outdoor Unit



Caution: discharge the refrigerant completely before removal.

XB

Step	Procedure
------	-----------

### 01

#### Before disassembly



### 02

#### Remove big handle and valve cover

Remove the screws fixing big handle, valve cover and then remove them.



### 03

#### Remove top cover

Remove the screws fixing top panel and then remove the top panel.



## Step

## Procedure

**04****Remove front panel assy**

Remove connection screws connecting the front panel assy with the chassis and the motor support, and then remove the front panel assy.

**05****Remove right side plate assy**

Rescrew the ground screws, remove the ground wires, loosen the screws fixing terminal board, remove the terminal board, rescrew the screws fixing the right plate, and remove the right side plate assy.

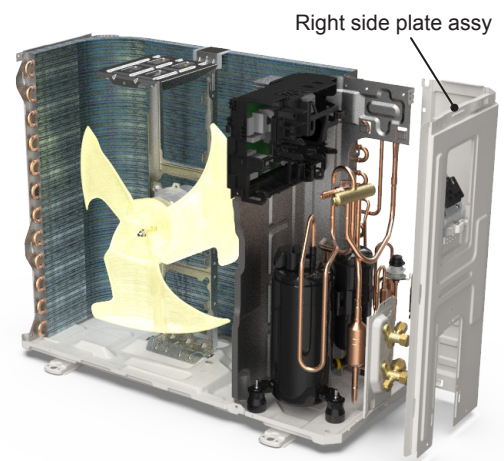
**06****Remove axial flow fan**

Remove the nut on the fan and then remove the axial flow fan.

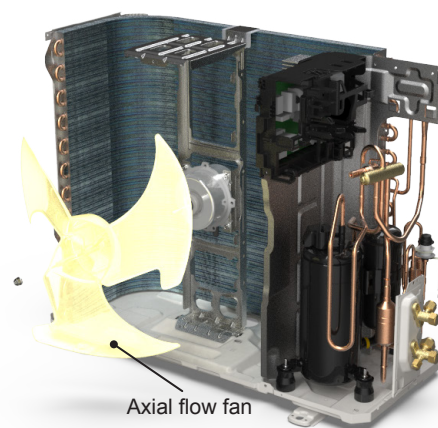

## Step

## Procedure

**07****Remove motor support and motor**

Remove the screws fixing the motor support and lift the motor support to remove it.

Remove the screws fixing the motor and then remove the motor.

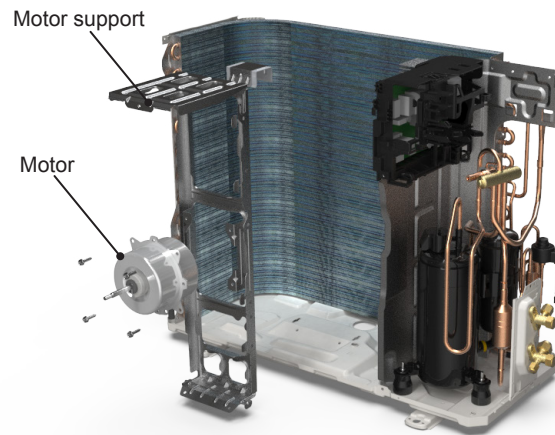
**08****Remove electric box assy**

Remove the terminals, lift up and rotate the electrical box assy to the right so that the snaps on the clapboard are removed and the electrical box assy are removed.

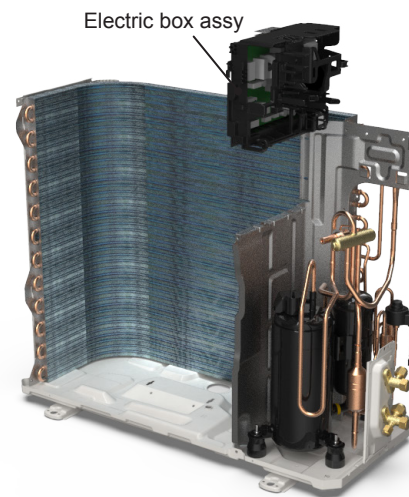
**09****Remove clapboard assy**

Remove the screws fixing the clapboard assy and then remove the clapboard assy.

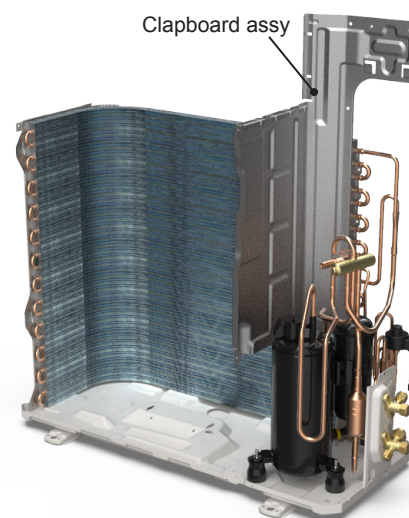

Step	Procedure
------	-----------

## 10

### Remove gas valve and liquid valve

Remove the valve support block, remove the screws fixing the gas valve and the liquid valve, unsolder the welding joint connecting the gas valve and the liquid valve, remove them.

**Note:**

Discharge the refrigerant completely before unsoldering; when unsoldering, wrap the gas valve with a wet cloth completely to avoid damage to the valve caused by high temperature.

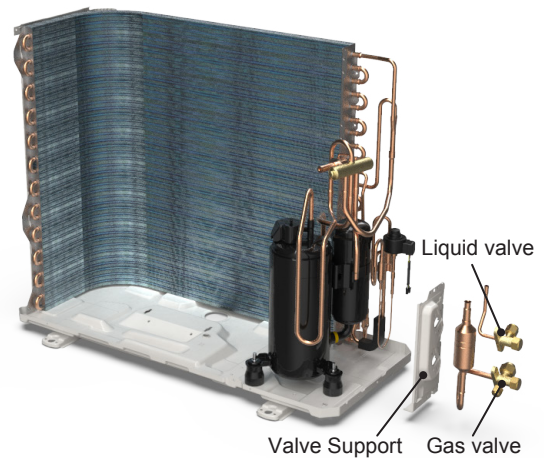

## 11

### Remove 4-way valve and electric expansion valve sub-assy

Unsolder the welding joints connecting the 4-way valve assembly, remove the 4-way valve.

Unsolder the spot weld of electric expansion valve sub-assembly and condenser, and then remove the electric expansion valve sub-assembly.

**Note:**

Before unsoldering the welding joint, wrap the 4-way valve with a wet cloth completely to avoid damage to the valve caused by high temperature. When unsoldering the spot weld, wrap the electric expansion valve sub-assembly with wet cloth completely to avoid damaging the valve due to high temperature.

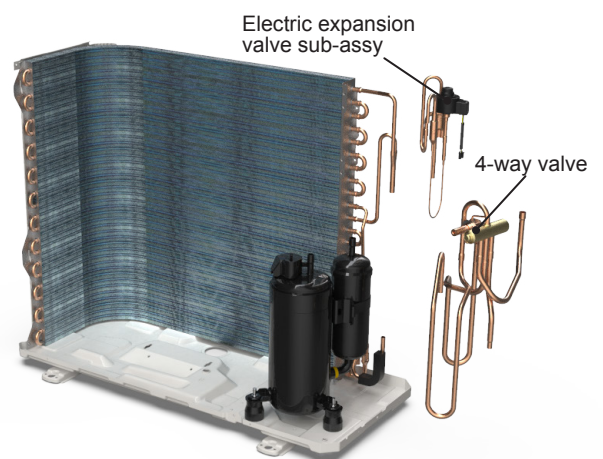

## 12

### Remove compressor

Remove the 3 foot nuts on the compressor and then remove the compressor.

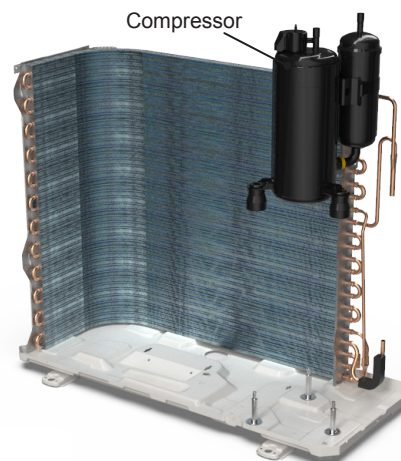

 **Caution: discharge the refrigerant completely before removal.**

XD

Step	Procedure
------	-----------

## 01

### Before disassembly



## 02

### Remove handle and valve cover

Remove the screws fixing handle, valve cover and then remove them.



## 03

### Remove top cover

Remove the screws fixing top panel and then remove the top panel.



## Step

## Procedure

**04****Remove front panel assy**

Remove connection screws connecting the front panel assy with the chassis and the motor support, and then remove the front panel assy.

**05****Remove right side plate assy**

Unscrew the ground screws, remove the ground wires, unscrew the screws fixing terminal board, remove the terminal board, unscrew the screws fixing the right plate, and remove the right side plate assy.

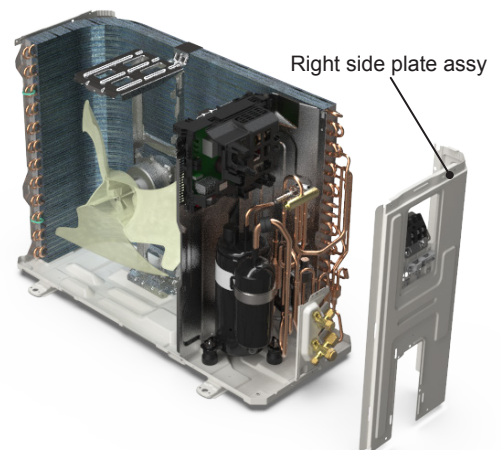
**06****Remove axial flow fan**

Remove the nut on the fan and then remove the axial flow fan.

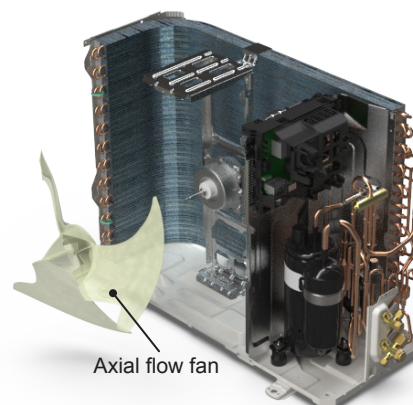

Step	Procedure
------	-----------

## 07

### Remove electric box assy

Remove the terminals, lift up and rotate the electrical box assy to the right so that the snaps on the clapboard are removed and the electrical box assy are removed.

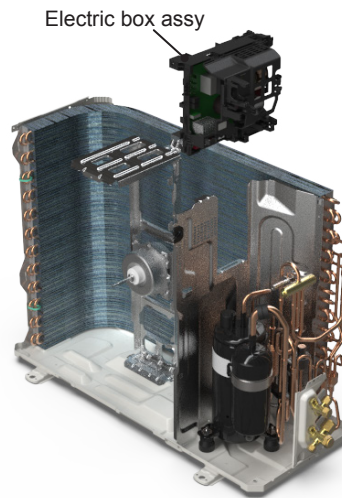

## 08

### Remove motor support and motor

Remove the screws fixing the motor support and lift the motor support to remove it.

Remove the screws fixing the motor and then remove the motor.

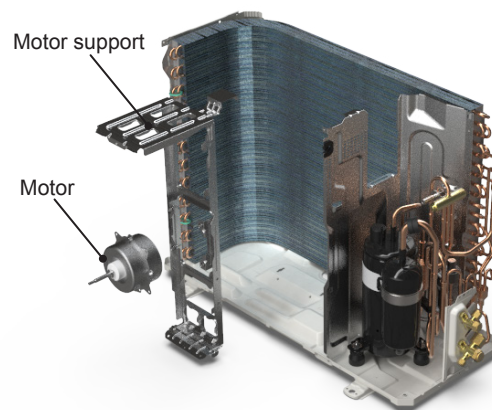

## 09

### Remove gas valve, liquid valve and valve support

Remove the valve support block, remove the screws fixing the gas valve and the liquid valve, unsolder the welding joint connecting the gas valve and the liquid valve, remove them.

**Note:**

Discharge the refrigerant completely before unsoldering; when unsoldering, wrap the gas valve with a wet cloth completely to avoid damage to the valve caused by high temperature.

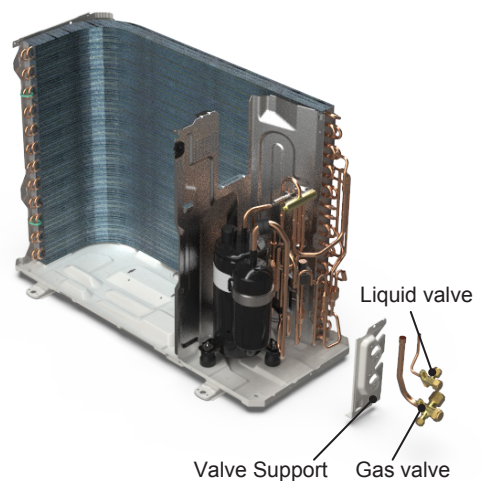

Step	Procedure
------	-----------

## 10

### Remove 4-way valve assy

Unsolder the welding joints connecting capillary, and then remove it.

Unsolder the welding joints connecting the 4-way valve assy with capillary sub-assy, compressor and condenser; remove the 4-way valve. Cooling only unit removes Discharge Tube and Inhalation Tube.

**Note:**

Before unsoldering the welding joint, wrap the 4-way valve with a wet cloth completely to avoid damage to the valve caused by high temperature.

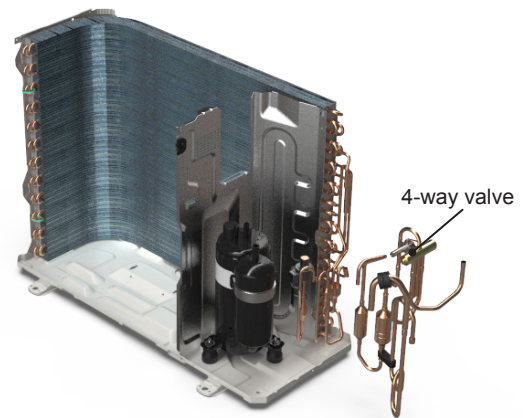

## 11

### Remove electric expansion valve sub-assy

Unsolder the spot weld of electric expansion valve sub-Assy and condenser, and then remove the electric expansion valve sub-Assy.

**Note:**

When unsoldering the spot weld, wrap the electric expansion valve sub-Assy with wet cloth completely to avoid damaging the valve due to high temperature.

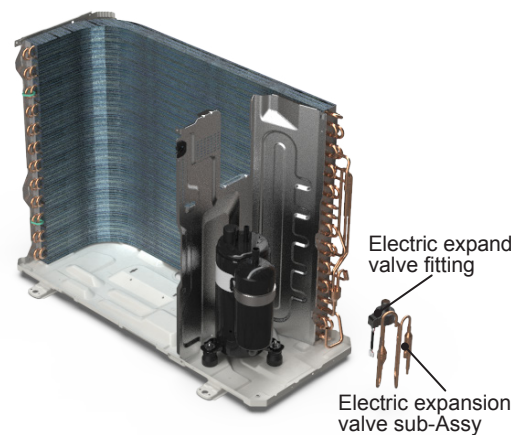

## 12

### Remove clapboard assy

Remove the screws fixing the clapboard assy and then remove the clapboard assy.

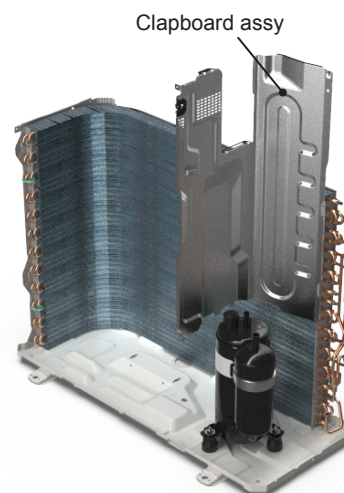

 **Caution: discharge the refrigerant completely before removal.**

XE

Step	Procedure
------	-----------

## 01

### Before disassembly

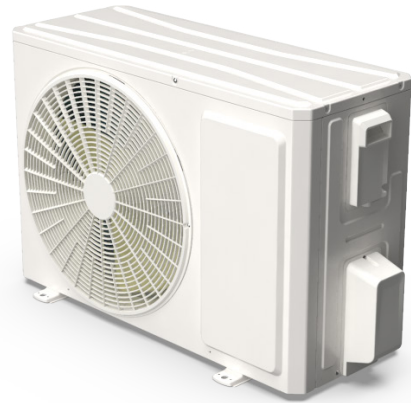

## 02

### Remove handle and valve cover

Remove the screws fixing handle, valve cover and then remove them.



## 03

### Remove top cover

Remove the screws fixing top panel and then remove the top panel.



## Step

## Procedure

**04****Remove front panel assy**

Remove connection screws connecting the front panel assy with the chassis and the motor support, and then remove the front panel assy.

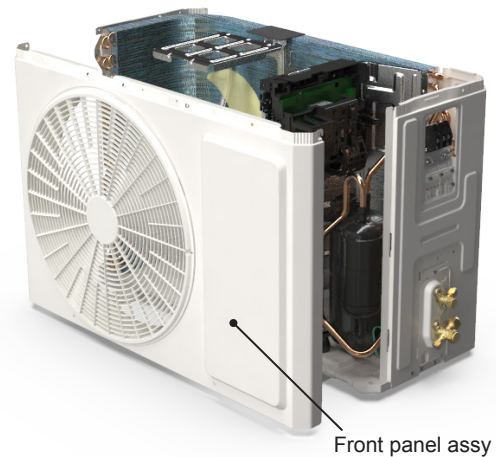
**05****Remove right side plate assy**

Unscrew the ground screws, remove the ground wires, unscrew the screws fixing terminal board, remove the terminal board, unscrew the screws fixing the right plate, and remove the right side plate assy.

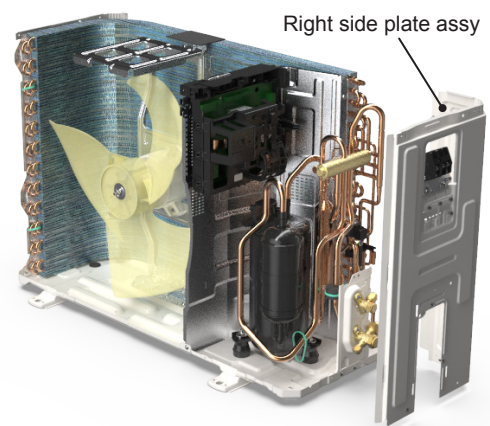
**06****Remove axial flow fan**

Remove the nut on the fan and then remove the axial flow fan.

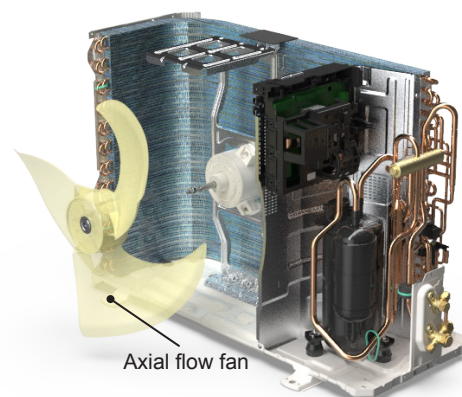

## Step

## Procedure

**07****Remove motor support and motor**

Remove the screws fixing the motor support and lift the motor support to remove it.

Remove the screws fixing the motor and then remove the motor.

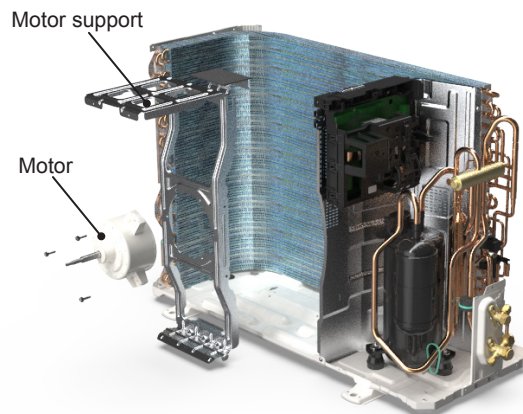
**08****Remove electric box assy**

Remove the terminals, lift up and rotate the electrical box assy to the right so that the snaps on the clapboard are removed and the electrical box assy are removed.

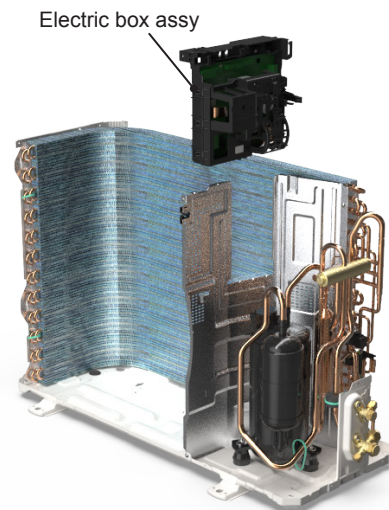
**09****Remove clapboard assy**

Remove the screws fixing the clapboard assy and then remove the clapboard assy.

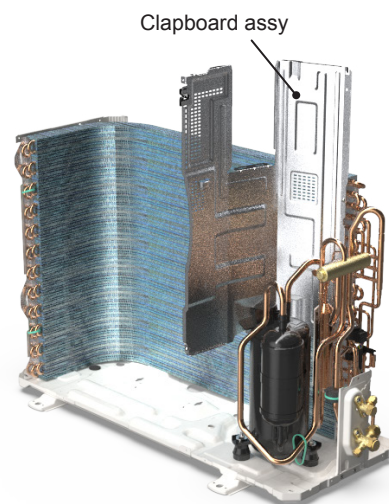

## Step

## Procedure

**10****Remove gas valve and liquid valve**

Remove the valve support block, remove the screws fixing the gas valve and the liquid valve, unsolder the welding joint connecting the gas valve and the liquid valve, remove them.

**Note:**

Discharge the refrigerant completely before unsoldering; when unsoldering, wrap the gas valve with a wet cloth completely to avoid damage to the valve caused by high temperature.

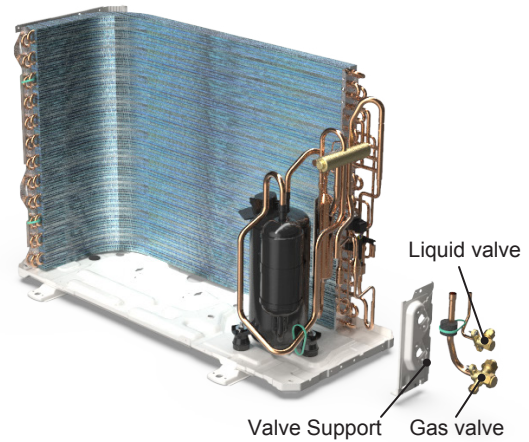
**11****Remove 4-way valve and electric expansion valve sub-assy**

Unsolder the welding joints connecting the 4-way valve assembly, remove the 4-way valve.

Unsolder the spot weld of electric expansion valve sub-assembly and condenser, and then remove the electric expansion valve sub-assembly.

**Note:**

Before unsoldering the welding joint, wrap the 4-way valve with a wet cloth completely to avoid damage to the valve caused by high temperature. When unsoldering the spot weld, wrap the electric expansion valve sub-assembly with wet cloth completely to avoid damaging the valve due to high temperature.

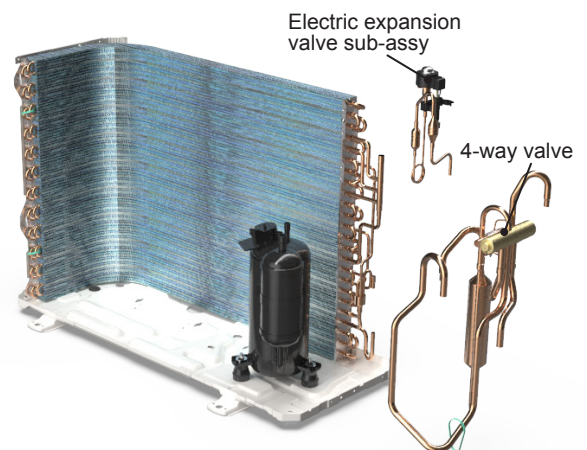
**12****Remove compressor**

Remove the 3 foot nuts on the compressor and then remove the compressor.

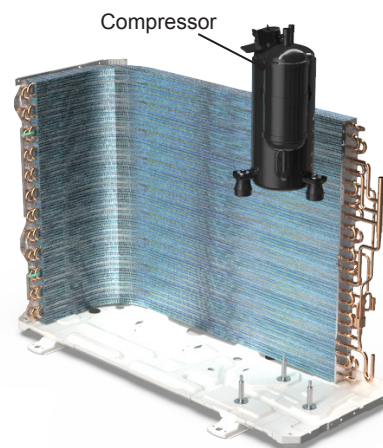

 **Caution: discharge the refrigerant completely before removal.**

XF

Step	Procedure
------	-----------

## 01

### Before disassembly



## 02

### Remove handle and valve cover

Remove the screws fixing handle, valve cover and then remove them.

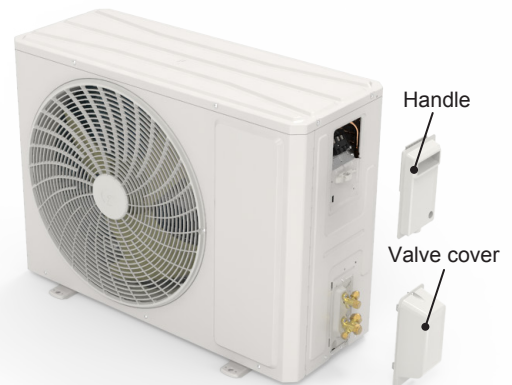

## 03

### Remove top cover

Remove the screws fixing top panel and then remove the top panel.



## Step

## Procedure

**04****Remove front panel assy**

Remove connection screws connecting the front panel assy with the chassis and the motor support, and then remove the front panel assy.

**05****Remove right side plate assy**

Unscrew the ground screws, remove the ground wires, unscrew the screws fixing terminal board, remove the terminal board, unscrew the screws fixing the right plate, and remove the right side plate assy.

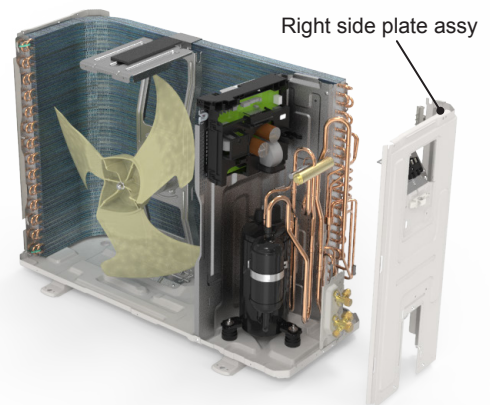
**06****Remove axial flow fan**

Remove the nut on the fan and then remove the axial flow fan.

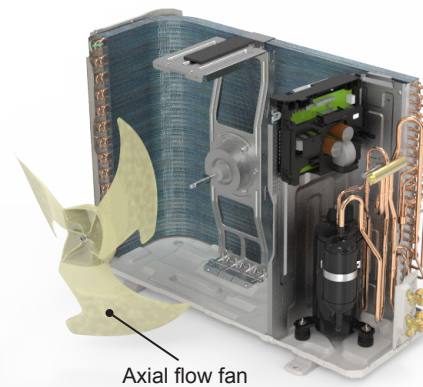

## Step

## Procedure

**07****Remove motor support and motor**

Remove the screws fixing the motor support and lift the motor support to remove it.

Remove the screws fixing the motor and then remove the motor.

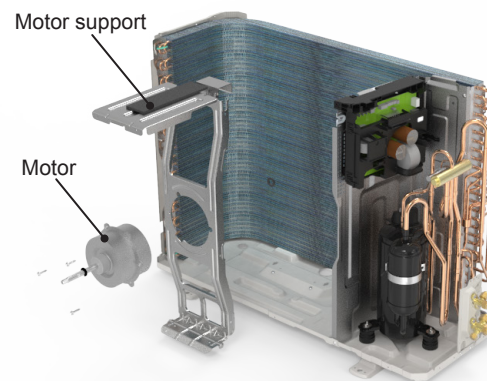
**08****Remove electric box assy**

Remove the terminals, lift up and rotate the electrical box assy to the right so that the snaps on the clapboard are removed and the electrical box assy are removed.

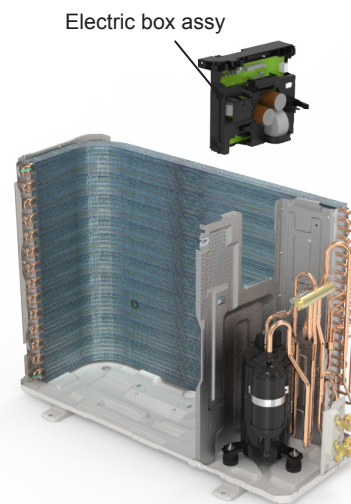
**09****Remove clapboard assy**

Remove the screws fixing the clapboard assy and then remove the clapboard assy.

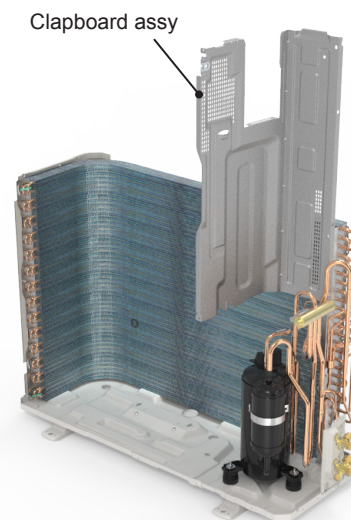

## Step

## Procedure

**10****Remove gas valve and liquid valve**

Remove the valve support block, remove the screws fixing the gas valve and the liquid valve, unsolder the welding joint connecting the gas valve and the liquid valve, remove them.

**Note:**

Discharge the refrigerant completely before unsoldering; when unsoldering, wrap the gas valve with a wet cloth completely to avoid damage to the valve caused by high temperature.

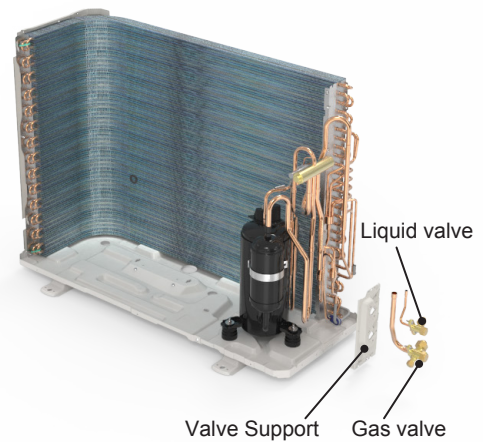
**11****Remove 4-way valve and electric expansion valve sub-assy**

Unsolder the welding joints connecting the 4-way valve assembly, remove the 4-way valve.

Unsolder the spot weld of electric expansion valve sub-assembly and condenser, and then remove the electric expansion valve sub-assembly.

**Note:**

Before unsoldering the welding joint, wrap the 4-way valve with a wet cloth completely to avoid damage to the valve caused by high temperature. When unsoldering the spot weld, wrap the electric expansion valve sub-assembly with wet cloth completely to avoid damaging the valve due to high temperature.

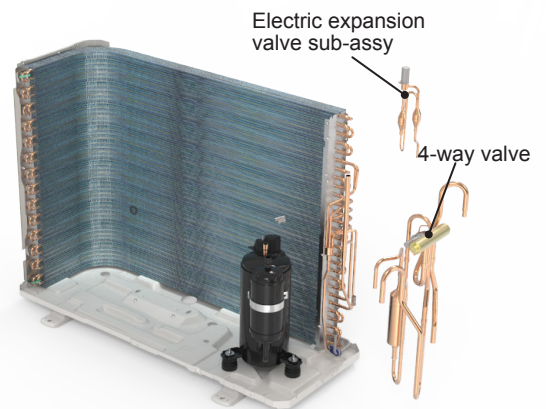
**12****Remove compressor**

Remove the 3 foot nuts on the compressor and then remove the compressor.

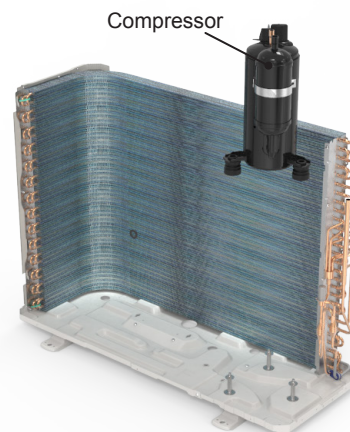

# Appendix

## Appendix 1 Reference Sheet of Celsius and Fahrenheit

### *Set temperature*

Fahrenheit display temperature (°F)	Fahrenheit (°F)	Celsius (°C)
61	60.8	16
62/63	62.6	17
64/65	64.4	18
66/67	66.2	19
68	68	20
69/70	69.8	21
71/72	71.6	22
73/74	73.4	23
75/76	75.2	24
77	77	25
78/79	78.8	26
80/81	80.6	27
82/83	82.4	28
84/85	84.2	29
86	86	30

## Ambient temperature

Fahrenheit display temperature (°F)	Fahrenheit (°F)	Celsius (°C)
32/33	32	0
34/35	33.8	1
36	35.6	2
37/38	37.4	3
39/40	39.2	4
41/42	41	5
43/44	42.8	6
45	44.6	7
46/47	46.4	8
48/49	48.2	9
50/51	50	10
52/53	51.8	11
54	53.6	12
55/56	55.4	13
57/58	57.2	14
59/60	59	15
61/62	60.8	16
63	62.6	17
64/65	64.4	18
66/67	66.2	19

Fahrenheit display temperature (°F)	Fahrenheit (°F)	Celsius (°C)
68/69	68	20
70/71	69.8	21
72	71.6	22
73/74	73.4	23
75/76	75.2	24
77/78	77	25
79/80	78.8	26
81	80.6	27
82/83	82.4	28
84/85	84.2	29
86/87	86	30
88/89	87.8	31
90	89.6	32
91/92	91.4	33
93/94	93.2	34
95/96	95	35
97/98	96.8	36
99	98.6	37

## Appendix 2 Configuration of Connection Pipe

1. Standard length of connection pipe (More details please refer to the specifications.)
2. Min length of connection pipe for the unit with standard connection pipe of 5m, there is no limitation for the min length of connection pipe. For the unit with standard connection pipe of 7.5m and 8m, the min length of connection pipe is 3m.
3. Max. length of connection pipe and max. high difference.(More details please refer to the specifications.)
4. The additional refrigerant oil and refrigerant charging required after prolonging connection pipe
  - After the length of connection pipe is prolonged for 10m at the basis of standard length, you should add 5ml of refrigerant oil for each additional 5m of connection pipe.
  - The calculation method of additional refrigerant charging amount (on the basis of liquid pipe):
  - Basing on the length of standard pipe, add refrigerant according to the requirement as shown in the table. The additional refrigerant charging amount per meter is different according to the diameter of liquid pipe. See the following sheet.
  - Additional refrigerant charging amount = prolonged length of liquid pipe X additional refrigerant charging amount per meter.

### Additional refrigerant charging amount for R32

Piping size		Outdoor unit throttle	
Liquid pipe	Gas pipe	Cooling only	Cooling and heating
1/4"	3/8" or 1/2"	12	16
1/4" or 3/8"	5/8" or 3/4"	12	40
1/2"	3/4" or 7/8"	24	96
5/8"	1" or 1 1/4"	48	96

## Appendix 3 Pipe expanding method

### NOTE:

Improper pipe expanding is the main cause of refrigerant leakage. Please expand the pipe according to the following steps:

### A: Cut the pipe

- Confirm the pipe length according to the distance of indoor unit and outdoor unit.
- Cut the required pipe with pipe cutter.

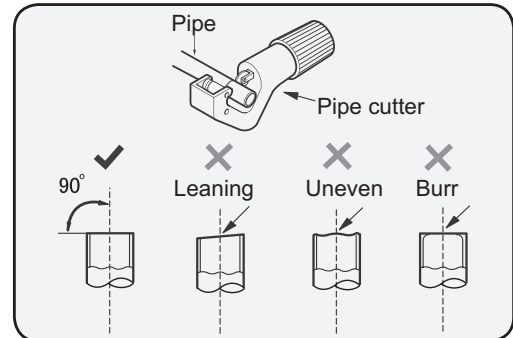

### B: Remove the burrs

- Remove the burrs with shaper and prevent the burrs from getting into the pipe.

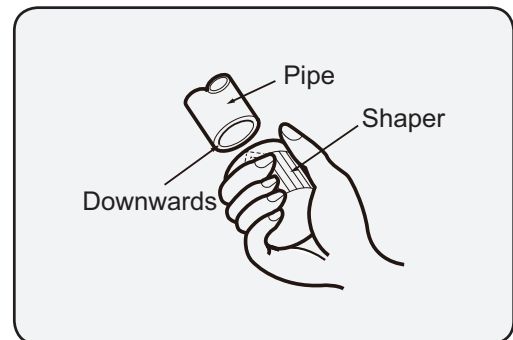

### C: Put on suitable insulating pipe

### D: Put on the union nut

- Remove the union nut on the indoor connection pipe and outdoor valve; install the union nut on the pipe.

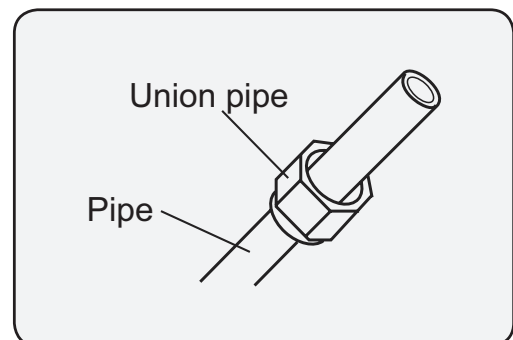

### E: Expand the port

- Expand the port with expander.

**NOTE:**

"A" is different according to the diameter, please refer to the sheet below:

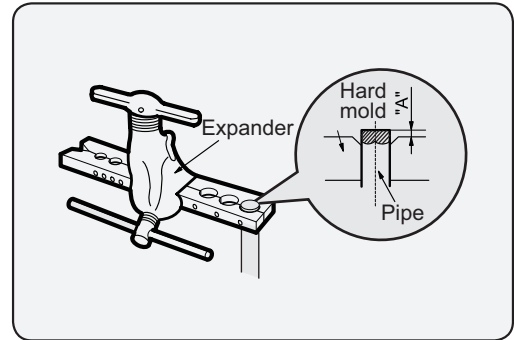

Outer diameter(mm)	A (mm)	
	Max	Min
Φ6 - 6.35 (1/4")	1.3	0.7
Φ9 - Φ9.52 (3/8")	1.6	1.0
Φ12 - 12.70 (1/2")	1.8	1.0
Φ16 - 15.88 (5/8")	2.4	2.2

### F: Inspection

- Check the quality of expanding port. If there is any blemish, expand the port again according to the steps above.

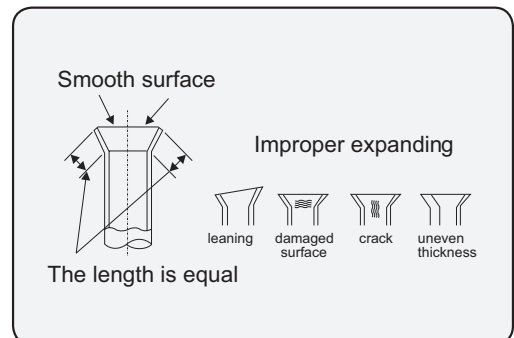

## Appendix 4 List of Resistance for Temperature Sensor

### *Resistance Table of Ambient Temperature Sensor for Indoor and Outdoor Units (15K)*

Temp (°C)	Resistance (kΩ)	Temp (°C)	Resistance (kΩ)
-19	138.10	20	18.75
-18	128.60	22	17.14
-16	115.00	24	15.68
-14	102.90	26	14.36
-12	92.22	28	13.16
-10	82.75	30	12.07
-8	74.35	32	11.09
-6	66.88	34	10.20
-4	60.23	36	9.38
-2	54.31	38	8.64
0	49.02	40	7.97
2	44.31	42	7.35
4	40.09	44	6.79
6	36.32	46	6.28
8	32.94	48	5.81
10	29.90	50	5.38
12	27.18	52	4.99
14	24.73	54	4.63
16	22.53	56	4.29
18	20.54	58	3.99

## ***Resistance Table of Tube Temperature Sensors for Indoor and Outdoor (20K)***

Temp (°C)	Resistance (kΩ)
-19	181.40
-15	145.00
-10	110.30
-5	84.61
0	65.37
5	50.87
10	39.87
15	31.47
20	25.01
25	20.00
30	16.10
35	13.04
40	10.62
45	8.71
50	7.17
55	5.94

Temp (°C)	Resistance (kΩ)
60	4.95
65	4.14
70	3.48
75	2.94
80	2.50
85	2.13
90	1.82
95	1.56
100	1.35
105	1.16
110	1.01
115	0.88
120	0.77
125	0.67
130	0.59
135	0.52

### ***Resistance Table of Discharge Temperature Sensor for Outdoor (50K)***

Temp (°C)	Resistance (kΩ)
-30	911.40
-25	660.80
-20	486.50
-15	362.90
-10	274
-5	209
0	161
5	125.10
10	98
15	77.35
20	61.48
25	49.19
30	39.61
35	32.09
40	26.15
45	21.43

Temp (°C)	Resistance (kΩ)
50	17.65
55	14.62
60	12.17
65	10.18
70	8.56
75	7.22
80	6.13
85	5.22
90	4.44
95	3.84
100	3.32
105	2.87
110	2.50
115	2.18
120	1.91
125	1.68

## Appendix 5 After-sales debugger operation Instruction

### 1. Applicable models

Model	Specific types	GT2A3Ac/d Debugger Applicable Models
Split unit	Inverter split unit (IDU power supply)	Applicable
	Inverter split unit (ODU power supply)	Applicable
Floor standing unit	Inverter	Applicable to T-fresh model and new models
Free match	Inverter	Applicable
Fixed frequency communication model	Split unit, T-fresh model and new models	Data monitor function only

NOTE: GT2A3Ac/d debugger is only suitable for 220V models, not for 110V models.

### 2. Appearance Introduction

- Appearance of GT2A3Ac/d debugger



- Button function description

- (1) OK button: Enter the selected function
- (2) Next button: Select a function or turn to another page
- (3) Home button: Return or back to the home page



USB interface of debugger

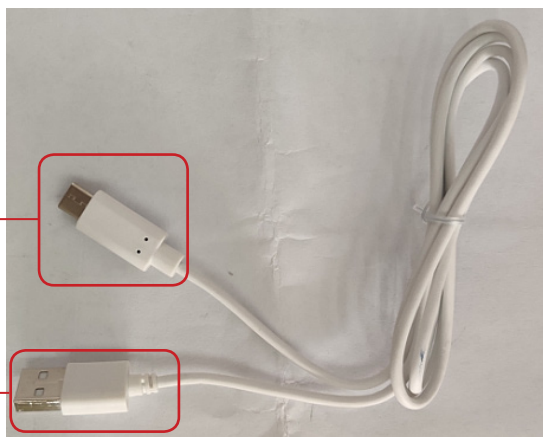

USB interface for connecting debugger

USB interface for connecting computer

### 3. *Precautions*

- **Be sure to read before use**

- (1) All wiring connection should be completed under power off status. Do not connect the debugger when the air conditioner is energized to avoid electric shock.
- (2) Before connecting the debugger to the air conditioner, make sure that the residual voltage of the air conditioner is discharged. Use multimeter to test the voltage between live wire and neutral wire, and the voltage between communication wire and neutral wire, the voltage should be 0V. After confirming the safety, connect the debugger and the wire, then power on.
- (3) Before removing the debugger from the terminal board, please power off the air conditioner first. Use the multimeter to test whether the voltage between the live line and the neutral line, and the voltage between the communication line and the neutral line are 0V. After the air conditioner is completely powered off, remove the connecting wire of the debugger.
- (4) It is necessary to ensure that the wire connection of the debugger is firm, live wire and the neutral wire cannot be reversed, otherwise the data will not be detected and "E6" will be displayed.
- (5) Do not use the debugger under severe weather such as thunderstorms, pay attention to moisture proof and water proof, and do not use the debugger under condensed water.

## 4. Function Introduction

- **Data monitor function**

This function is mainly used to detect the operating parameters of the whole unit. The display interface is as follows:

● Run mode:	Cool
● Compressor frequency:	0Hz
● Expansion valve:	150Step
● Module temp.:	45°C
● Outdoor ambient temp.:	25°C
● Discharge temp.:	89°C
● External tube temp.:	25°C
● DC bus voltage:	308V
<hr/>	
End	

- **Replae the IDU to detect the ODU**

This function is used to detect the operating status of the ODU, and display the operating parameters of the ODU. If there is a fault, it will display the error code of the ODU.

- **Replace the ODU to detect the IDU**

This function is used to detect the operating status of the IDU, and display the operating parameters of the IDU. If there is a fault, it will display the error code of the IDU.

● Run mode:	Cool
● Indoor fan speed:	High
● Set temp.:	19°C
● Indoor ambient temp.:	26°C
● Indoor tube temp.:	24°C
<hr/>	
Next	

## 5. Wiring Instruction

- **Power cord connection instruction of debugger**

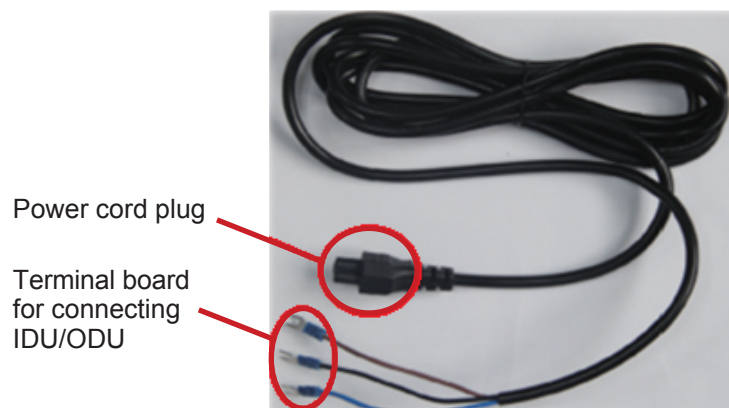
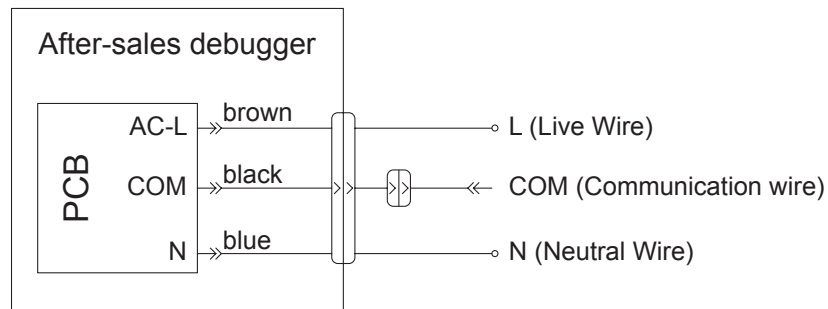

### NOTE:

1. The communication line (COM) should be connected to the communication terminal of the indoor unit or the outdoor unit. Some models do not have terminal board on IDU, and the communication wire COM can be connected to the terminal board of ODU.
2. Please connect power only after the wires are properly connected. The neutral wire and live wire must not be reversed. Wires of the debugger must be securely connected to the AC; otherwise, data cannot be detected and E6 will be displayed.

- **Wiring instruction of Data monitor function**

Cut off the power of the air conditioner and make sure that the residual voltage of the air conditioner is discharged. Connect the connection wires of the debugger to the IDU or ODU terminal board in parallel. The connection wires must correspond to each other and cannot be reversed. Power on the whole unit again and enter the Data Detection Function from the debugging interface. The wiring diagram is as follows:

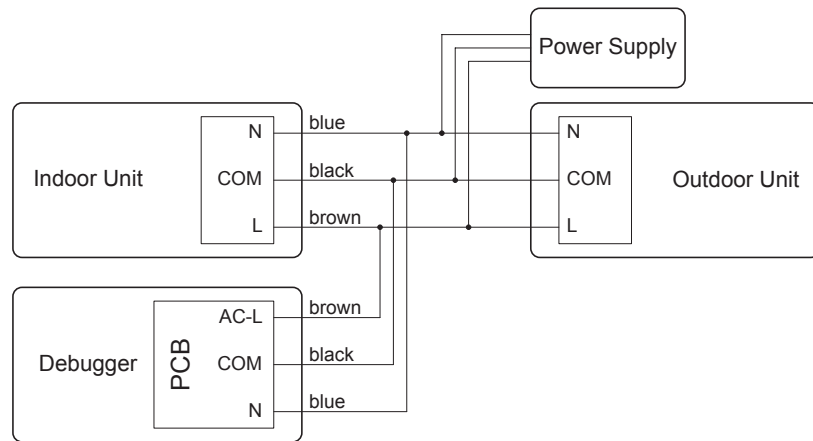

**NOTE:**

1. Before connecting or disconnecting the wires to the air conditioner, pls cut off the power of the air conditioner and make sure that the residual voltage of the air conditioner is discharged.
2. AC-L connect brown wire, COM connect black wire, N connect blue wire, the wires can not be connected reversely.

● **Wiring instruction of Replacing the IDU to detect the ODU**

If selecting the function of Replace the IDU to detect ODU, the debugger is equivalent to an IDU and will detect whether the ODU is abnormal. when using this function, disconnect the communication wire of the IDU and connect the communication wire of the debugger with the communication wire of ODU.

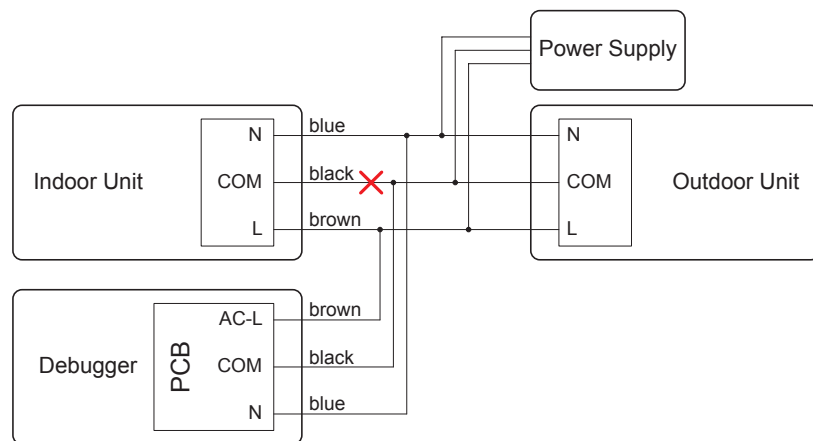

The power cord of the debugger can be connected to the terminal board of the IDU or the ODU. Note that the communication wire(black wire) of the IDU main board must be disconnected from the terminal board. As shown below:

When the debugger is connected to the IDU terminal board, the COM communication wire (black) of IDU must be disconnected.

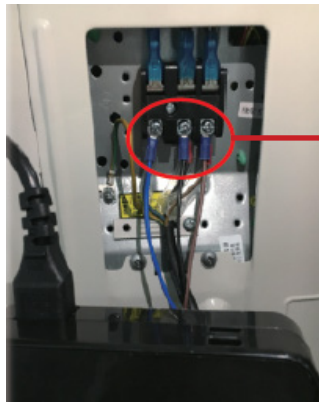
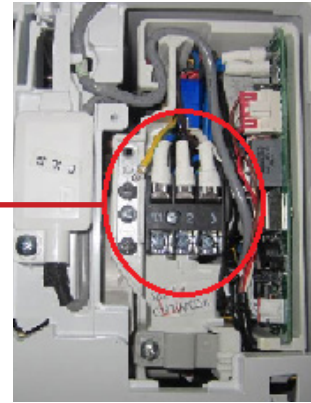

If the debugger is connected to the ODU terminal board, the communication wire of the IDU must also be disconnected.

#### NOTE:

1. Before connecting or disconnecting the wires to the air conditioner, please cut off the power of the air conditioner and make sure that the residual voltage of the air conditioner is discharged.
2. AC-L connect brown wire, COM connect black wire, N connect blue wire, the wires can not be connected reversely.
3. It is only used to let the ODU run for a short time for troubleshooting, and it should not run for more than 10 minutes.

#### ● **Wiring instruction of Replacing the ODU to detect the IDU**

If selecting the function of **Replace the ODU to detect IDU**, the debugger is equivalent to an ODU and will detect whether the IDU is abnormal. when using this function, disconnect the communication wire of the ODU and connect the communication wire of the debugger with the communication wire of IDU.

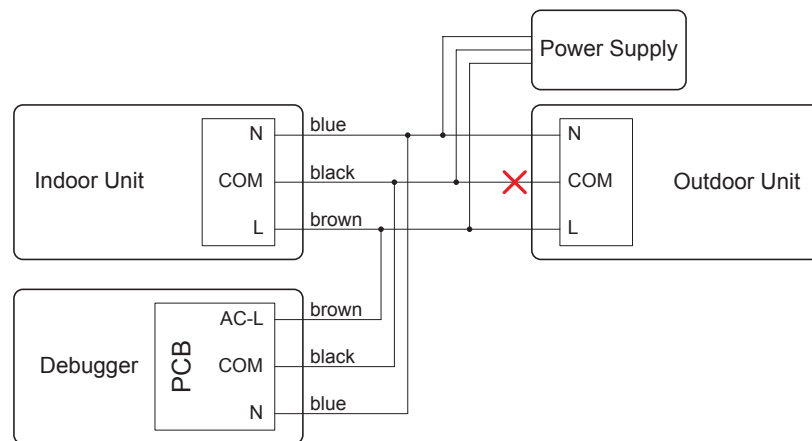

The power cord of the debugger can be connected to the terminal board of the IDU or the ODU. Note that the communication wire (black wire) of the ODU must be disconnected from the terminal board. As shown below:

The COM communication wire of ODU needs to be disconnected.

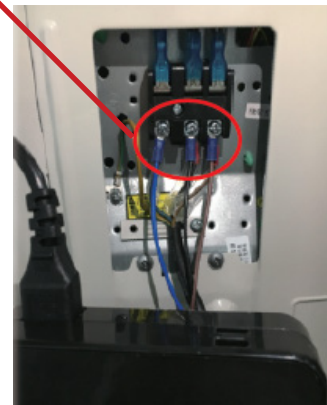
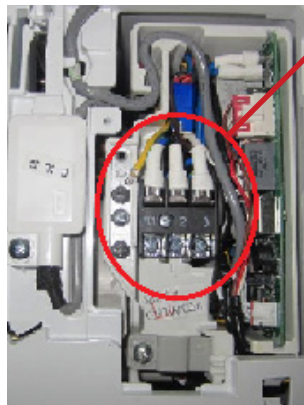

### NOTE:

1. Before connecting or disconnecting the wires to the air conditioner, please cut off the power of the air conditioner and make sure that the residual voltage of the air conditioner is discharged.
2. AC-L connect brown wire, COM connect black wire, N connect blue wire, the wires can not be connected reversely.
3. For free match models, it need to replace and connect the IDU one by one for troubleshooting.



**GREE ELECTRIC APPLIANCES, INC. OF ZHUHAI**

Add: West Jinji Rd, Qianshan, Zhuhai, Guangdong, China, 519070  
Tel: (+86-756) 8522219  
Fax: (+86-756) 8669426  
E-mail: [global@cn.gree.com](mailto:global@cn.gree.com)

**For product improvement, specifications and appearance in this manual are subject to change without prior notice.**

JF00305975